

F665VIC Technical Data Sheet

Pressure Enhanced Rubber Seat



Technical Data	
Fluid	chilled or hot water, up to 60% glycol
Flow characteristic	modified equal percentage
Controllable flow range	90° rotation
Valve Size [mm]	2.5" [65]
Pipe connection	grooved ANSI/AWWA (c606)
Housing	Ductile cast iron ASTM A536
Body finish	black alkyd enamel
Stem	416 stainless steel
Spindle bearing	fiberglass with TFE lining
Seat	EPDM
Disc	electroless nickel coated ductile iron
Body Pressure Rating	ANSI Class Grooved AWWA, 300 psi
ANSI Class	Grooved AWWA
Rangeability Sv	100:1
Maximum Velocity	20 FPS
Cv	260
Weight	4.9 lb [2.2 kg]
Fluid Temp Range (water)	-22...250°F [-30...120°C]
Leakage rate	0%
Servicing	maintenance-free

Close-off pressures are variable and actuator dependent, consult Select Pro and/or Price Guide for specifics.

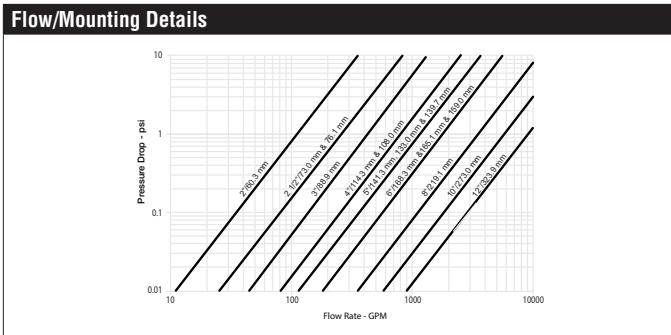

Application

These valves are designed to meet the needs of HVAC and commercial applications requiring bubble tight shut-off for liquids. Typical applications include chiller isolation, cooling tower isolation, change-over systems, large air handler coil control, bypass and process control applications. The large Cv values provide for an economical control valve solution for larger flow applications. Designed for use in Victaulic® piping systems.

Jobsite Note

Valve assembly should be stored in a weather protected area prior to installation. Reference the butterfly valve installation instruction for additional information.

Flow/Cv					
Cv 30°	Cv 40°	Cv 50°	Cv 60°	Cv 70°	Cv 90°
16	30	50	80	140	260

Suitable Actuators		
	Non-Spring	Spring
F665VIC	AMB(X), GRCB(X), GMB(X)	AFB(X)

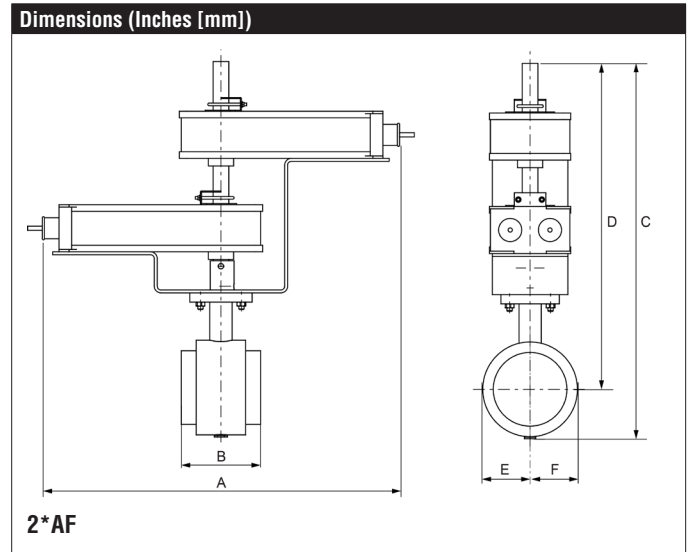

A	B	C	D	E	F
17.0" [433]	3.8" [97]	16.4" [416]	14.3" [363]	2.0" [51]	

Date created, 04/14/2020 - Subject to change. © Belimo Aircontrols (USA), Inc.

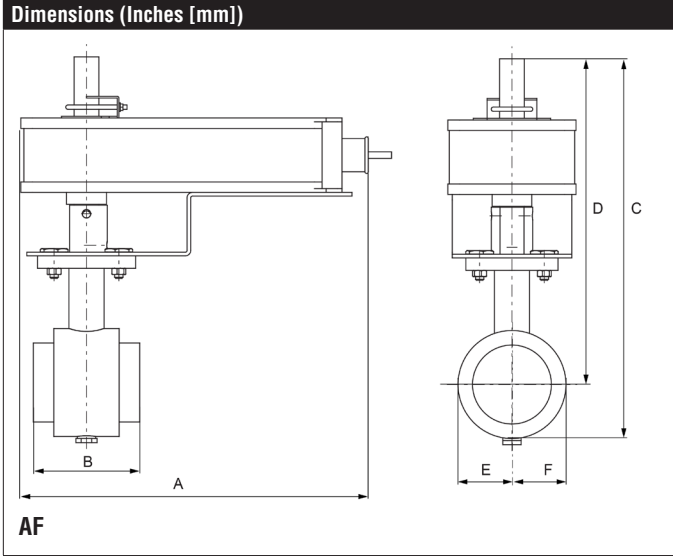

A	B	C	D	E	F
10.5" [267]	3.8" [97]	12.3" [312]	10.2" [260]	2.0" [51]	

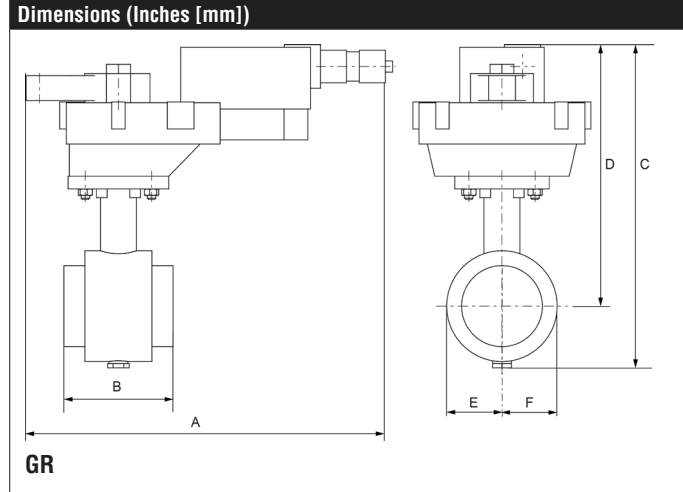

A	B	C	D	E	F
10.8" [275]	3.8" [97]	10.2" [260]	8.1" [206]	2.0" [51]	

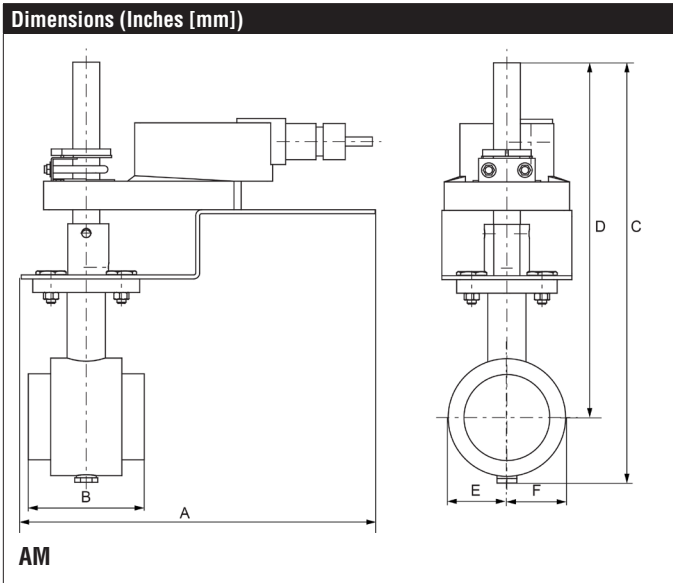

A	B	C	D	E	F
9.8" [249]	3.8" [97]	12.3" [312]	10.2" [260]	2.0" [51]	

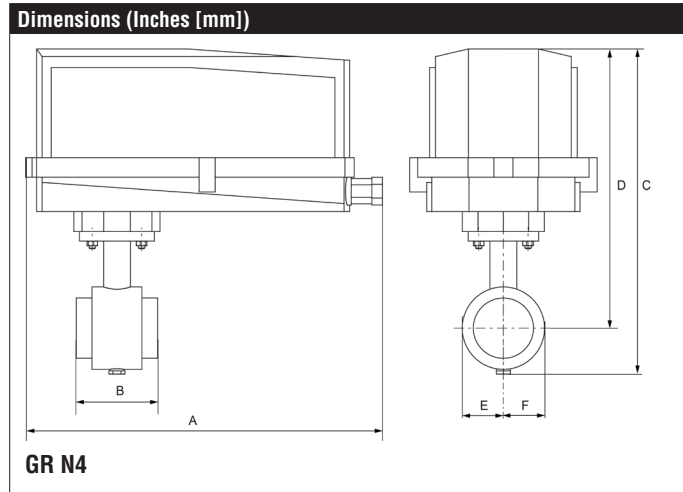

A	B	C	D	E	F
14.1" [358]	3.8" [97]	13.6" [345]	11.5" [292]	2.0" [51]	

F665VIC Technical Data Sheet

Pressure Enhanced Rubber Seat

Dimensions (Inches [mm])

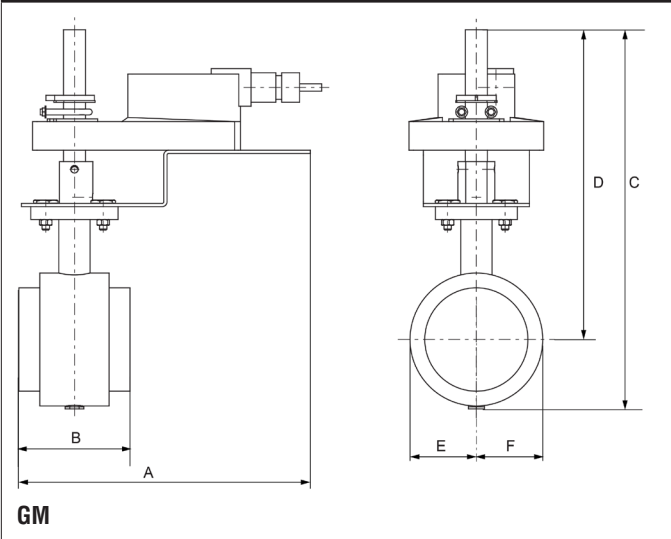

A	B	C	D	E	F
9.9" [251]	3.8" [97]	12.3" [312]	10.2" [260]	2.0" [51]	

GMCX120-SR-T-X1 Technical Data Sheet

Modulating, Non-Spring Return, AC 100...240 V, for DC 2...10 V or 4...20 mA

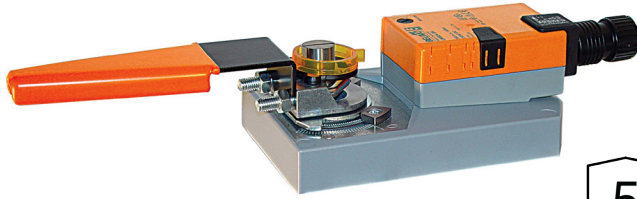

5-year warranty



Technical Data	
Power Supply	100...240 VAC, ±20%, 50/60 Hz
Power consumption in operation	6 W
Power consumption in rest position	2 W
Electrical Connection	1/2" conduit connector, screw terminals
Overload Protection	electronic throughout 0...95° rotation
Operating Range	DC 2...10 V, 4 to 20 mA w/ ZG-R01 (500 Ω, 1/4 W resistor)
Input Impedance	500 Ω
Angle of rotation	90°, adjustable with mechanical stop
Direction of motion motor	selectable with switch 0/1
Position indication	Mechanically, pluggable
Manual override	external push button
Running Time (Motor)	35 s, constant, independent of load
Ambient humidity	max. 95% r.H., non-condensing
Ambient temperature	-22...122°F [-30...50°C]
Storage temperature	-40...176°F [-40...80°C]
Degree of Protection	IP54, NEMA 2, UL Enclosure Type 2
Housing material	UL94-5VA
Agency Listing	cULus acc. to UL60730-1A/-2-14, CAN/CSA E60730-1:02, CE acc. to 2004/108/EC and 2006/95/EC
Noise level, motor	60 dB(A)
Servicing	maintenance-free
Quality Standard	ISO 9001
Weight	3.53 lb [1.6 kg]

†Rated Impulse Voltage 4kV, Type of action 1, Control Pollution Degree 3.

Date created, 12/20/2019 - Subject to change. © Belimo Aircontrols (USA), Inc.

Wiring Diagrams

✂ INSTALLATION NOTES

- Provide overload protection and disconnect as required.
- Actuators may be connected in parallel. Power consumption and input impedance must be observed.
- Only connect common to negative (-) leg of control circuits.
- Actuators are provided with a numbered screw terminal strip instead of a cable.
- Meets cULus requirements without the need of an electrical ground connection.

WARNING! LIVE ELECTRICAL COMPONENTS!
 During installation, testing, servicing and troubleshooting of this product, it may be necessary to work with live electrical components. Have a qualified licensed electrician or other individual who has been properly trained in handling live electrical components perform these tasks. Failure to follow all electrical safety precautions when exposed to live electrical components could result in death or serious injury.

