

Belimo Energy Valve™ for ANSI 125 and 250 Flanged Installation

Inlet

The Energy Valve requires a section of straight pipe on the valve inlet to guarantee sensor accuracy. The length should be at least 5 diameters long.

2½" [DN65] 5 x nominal pipe size = 12½" [317 mm]

3" [DN80] 5 x nominal pipe size = 15" [381 mm]

4" [DN100] 5 x nominal pipe size = 20" [508 mm]

5" [DN125] 5 x nominal pipe size = 25" [635 mm]

6" [DN150] 5 x nominal pipe size = 30" [762 mm]

Outlet Length

No requirements for outlet length.

Elbows can be installed directly after the valve.

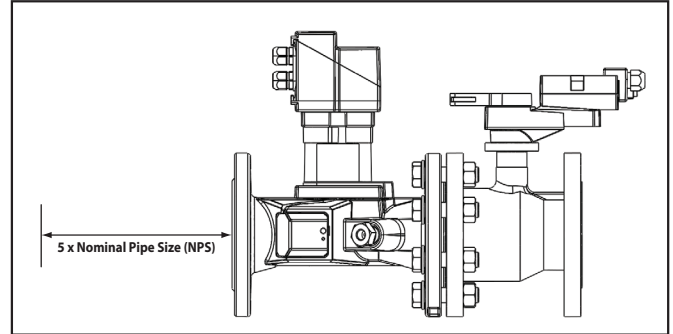

Remote Sensor Installation:

A thermo well is provided with the remote temperature sensor. The well should be installed on the pipe prior to installing the remote temperature sensor. The remote temperature sensor should be installed on the opposite pipe entering the coil from where the Energy Valve is installed. A ½" NPT female union should be welded on the pipe to allow the installation of the thermo well. The Energy Valve is equipped with a 32 ft. (10m) cable for the remote sensor. If a shorter remote sensor cable is required, the cable is also available in the following sizes: 4.9 ft. (1.5m), 9.8 ft. (3m) or 16.4 ft (5m). Please order the appropriate size for the application.

IN	DN [mm]	EL	ET	L max.
2½"	65	3.66" [93]	2.36" [60]	1.18" [30]
3"	80	3.66" [93]	2.36" [60]	1.18" [30]
4"	100	3.66" [93]	2.36" [60]	1.18" [30]
5"	125	3.66" [93]	2.36" [60]	1.18" [30]
6"	150	3.66" [93]	2.36" [60]	1.18" [30]

Insulation

The insulation should be below the actuator

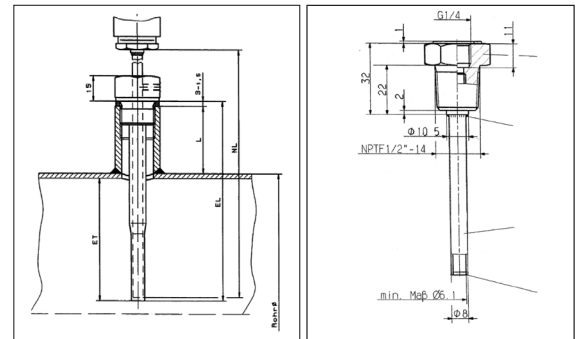
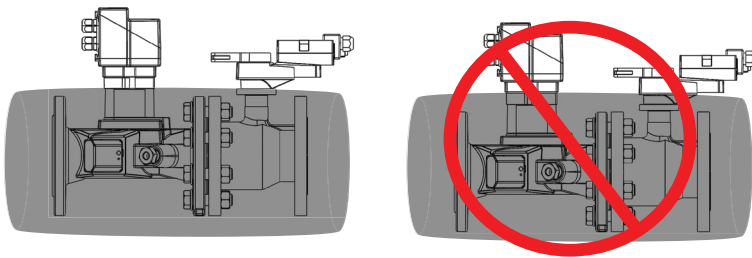

How to build the remote well

Valve Nominal Size		Weight Pounds [kg]	
IN	DN [mm]	ANSI 125	ANSI 250
2½"	65	52 [23.3]	54 [24.5]
3"	80	63 [28.3]	63 [28.3]
4"	100	89 [40.1]	99 [44.9]
5"	125	120 [54.3]	126 [57.2]
6"	150	154 [69.6]	173 [78.5]

Orientation

Energy Valves shall be installed with flow in the direction of the arrow on the valve body.

The valve assembly can be installed in a vertical or horizontal arrangement, as long as the actuator is positioned to avoid condensation from dripping onto the actuator.

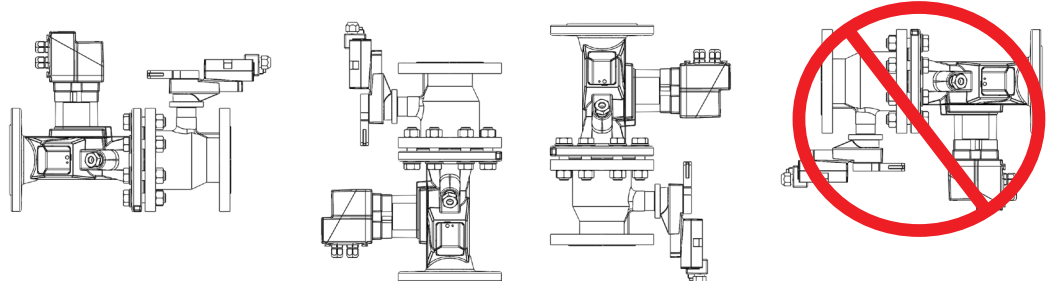

Installation Instructions

Belimo Energy Valve

Piping

The Energy Valve is recommended to be installed on the return side of the coil. This diagram is for typical applications only. Consult engineering specification and drawings for particular circumstances. Install provided thermal well on the other side of the coil (T1). P/T ports are recommended on either side of the valve and the supply side of the heat transfer device to allow for pressure/flow measurement/calculation. It is not necessary to install one strainer per unit. Belimo recommends installing one strainer per system. If the system has multiple branches, it is recommended to install one strainer per branch.

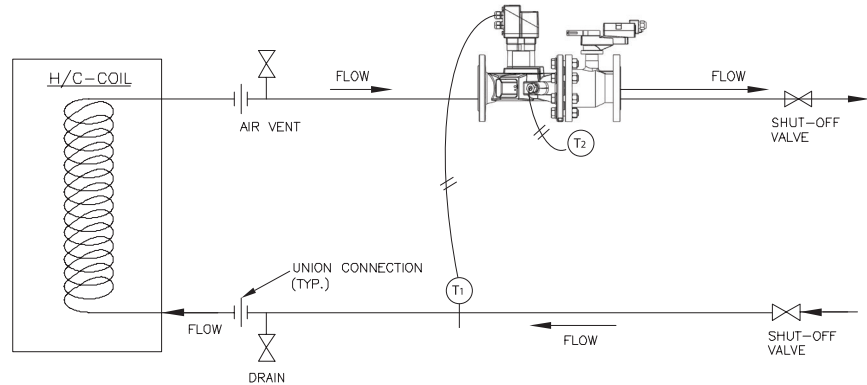

General Warnings

Valve should not be used for combustible gas applications. Gas leaks and explosions may result. Do not install in systems, which exceed the ratings of the valve.

- Avoid installations where valve may be exposed to excessive moisture, corrosive fumes, vibration, high ambient temperatures, elements, or high traffic areas with potential for mechanical damage.
- Valve assembly location must be within ambient ratings of actuator. If temperature is below -14°F for ANSI 125 and -22°F for ANSI 250 a heater is required.
- The valve assembly will require heat shielding, thermal isolation, or cooling if combined effect of medium and ambient temperatures – conduction, convection, and radiation – is above 122°F for prolonged time periods at the actuator.
- Visual access must be provided. Assembly must be accessible for routine schedule service. Contractor should provide unions for removal from line and isolation valves.
- Avoid excessive stresses. Mechanical support must be provided where reducers have been used and the piping system may have less structural integrity than full pipe sizes.
- Sufficient upstream piping runs must be provided to ensure proper valve capacity and flow response. See installation section for details.
- Life span of valve stems and O-rings is dependent on maintaining non-damaging conditions. Poor water treatment or filtration, corrosion, scale, other particulate can result in damage to trim components. A water treatment specialist should be consulted.
- It is not necessary to install one strainer per unit. Belimo recommends installing one strainer per system. If the system has multiple branches, it is recommended to install one strainer per branch.
- **WARNING:** Lift Energy Valve from valve body. Do not lift this valve by the actuator. Lifting the valve body by the actuator can break the linkage and void the warranty.



WARNING:

This product can expose you to lead which is known to the State of California to cause cancer and reproductive harm. For more information go to

www.P65Warnings.ca.gov

Installation

1. Inspect shipping package, valve, linkage, and actuator for physical damage. If shipping damage has occurred notify appropriate carrier. Do not install.
2. If a replacement, remove existing valve, linkage, and actuator from the piping system.
3. If actuator and linkage are removed, they must be reinstalled correctly. The actuator must be rotated so that the valve seats properly for close off.
4. Install valve with the proper ports as inlets and outlets. Check that inlet and outlet of 2-way valves are correct. Flow direction arrows must be correct.
5. Blow out all piping and thoroughly clean before valve installation.
6. Clean flanges with wire brush and rag. Clean pipes, flanges, and valve flanges before installation; check for any foreign material that can become lodged in trim components. Strainers should be cleaned after initial startup.
7. Valve must be installed with the stem towards the vertical, not below horizontal.
8. -125 models are designed to be installed between ANSI Class 125/150 flanges only. -250 models are designed to be installed between ANSI Class 250/300 flanges only.
9. Carefully follow installation using ANSI piping practices.