



**FSKN120-BAC &
FSKN24-BAC
BACnet & Modbus**

BACnet and Modbus protocol guide



Discover the advantages
www.belimo.com

BELIMO[®]

FSKN 120-BAC & FSKN24-BAC BACnet & Modbus Information

Remote testing module for actuated fire & smoke dampers via BACnet & Modbus

- Communication via BACnet MS/TP and Modbus RTU (RS-485)
- AC 24 V (+/- 10%), DC 24 V (+10%, -0%)
- AC 120 V (+/- 10%)
- Testing and status reporting initiated by a single command
- FSTF, FSLF, FSNF, FSAFB & FSAF*A actuators.

For initial start up and LED indications see FSKN Installation Instructions.

For wiring diagrams for various other electrical arrangements see FSKN Application Guide

For data sheets see FSKN24-BAC or FSKN120-BAC on Belimo.com

For questions, contact: customerservice@us.belimo.com or call 800-543-9038

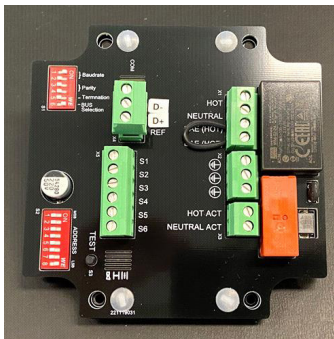

FSKN120-BAC

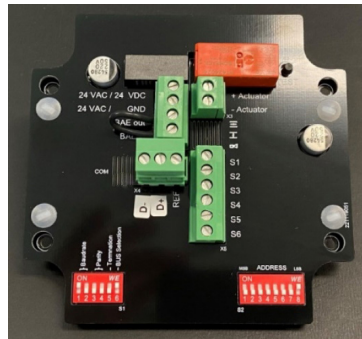

FSKN24-BAC

Circuit boards for both models are identical in functions



WARNING!

The FSKN is not to be used in smoke control systems for any safety function. It is not UL 864 UUKL listed. It is an interface for testing containment dampers per Chapter 7 of the IBC and IFC only. Use the FSKN with spring return closed dampers only.

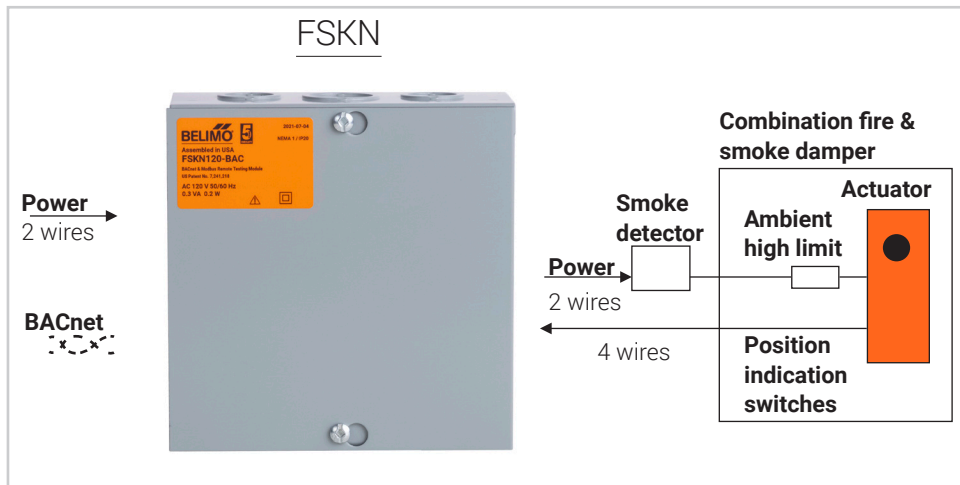

Overview of FSKN application – see data sheets or FSKN Installation Instructions for wiring details

The FSKN has a normally closed relay that passes power through to the standard fire and smoke damper safeties – a smoke detector and the high temperature limit on the damper. Activation of a test will open the relay to spring close the damper. The position indication switches are monitored to prove proper function. A pass or fail message is then available for BACnet to record.

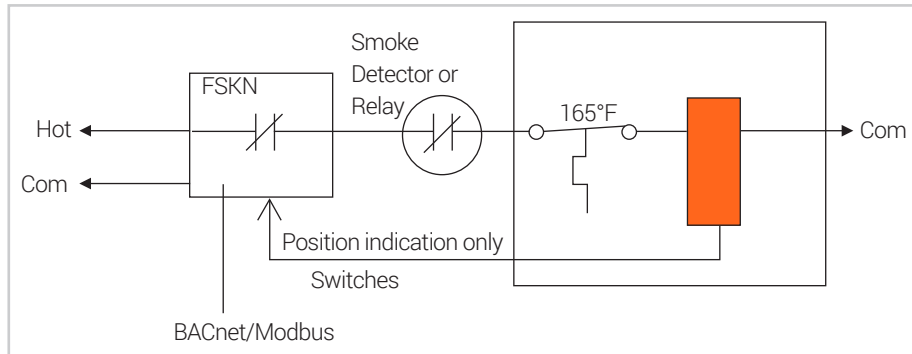

General Information BACnet

Date	July 2022
Vendor Name	BELIMO Automation AG
Vendor ID	423
Product Model Numbers	FSKN120-BAC, FSKN24-BAC
Applications Software Version	1.0.4
BACnet Protocol Revision	14
Product Description	Test module for actuated fire and combination fire & smoke Dampers in containment applications
BACnet Standard Device Profile	BACnet Application Specific Controller (B-ASC)
BACnet Interoperability Building Blocks supported (BIBBs):	<ul style="list-style-type: none"> – Data sharing – ReadProperty-B (DS-RP-B) – Data sharing – ReadPropertyMultiple-B (DS-RPM-B) – Data sharing – WriteProperty-B (DS-WP-B) – Data sharing – COV-B (DS-COV-B) – Device management – DynamicDeviceBinding-B (DM-DDB-B) – Device management – DynamicObjectBinding-B (DM-DOB-B) – Device management – DeviceCommunicationControl-B (DM-DCC-B)
Segmentation capability	No
Data Link Layer Options	MS/TP master
Baud rats:	9,600; 19,200; 38,400; 76,800
Device Address Binding	No static device binding supported
Networking Options	None
Character Sets supported	ISO 10646 (UTF-8)
Gateway Options	None
Network Security Options	Non-secure device
Conformance	BTL Certified April 2022

BACnet interface information

Object processing

Object type	Optional properties	Writable properties
Analog Input [AI]	Description COV increment	COV increment
Analog Value [AV]	Description COV increment	Present value COV increment
Binary Input [BI]	Description Active text Inactive text	
Device	Description Location Active COV Subscriptions Max Master Max Info Frames	Object Name Location APDU timeout (1000...60'000) Number of APDU Retries (0...10) Max Master (1...127) Max Info Frames (1...255)
Multi-state Input [MI]	Description State text	
Multi-state Value [MV]	Description State text	

- The device does not support the services CreateObject and DeleteObject.
- The specified maximum length of writable strings is based on single-byte characters.
 - Object name: 32 characters
 - Location: 64 characters
 - Description: 64 characters

Service processing

- The device supports the DeviceCommunicationControl and ReinitializeDevice services. No password is required.
- A maximum of 64 active COV subscriptions with a lifetime of 1...28800 sec. (8 hours) are supported.

BACnet Dip switch settings

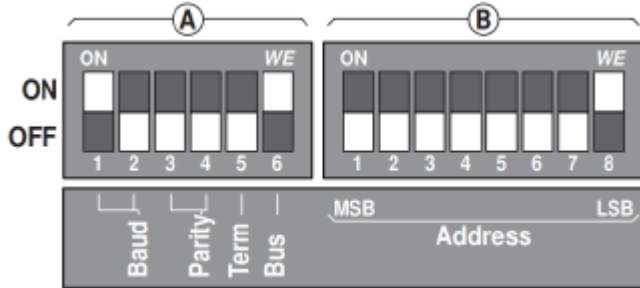

Baud rate	1	2	Parity	3	4	Termination	5	Bus	6
9'600	OFF	OFF	1-8-N-2	OFF	OFF	with 150 Ω	ON	BACnet	ON
19'200	OFF	ON	1-8-N-1	OFF	ON	OFF	OFF	Modbus	OFF
38'400	ON	OFF	1-8-E-1	ON	OFF				
76'800	ON	ON	1-8-O-1	ON	ON				

BACnet address	1	2	3	4	5	6	7	8
0		OFF	OFF	OFF	OFF	OFF	OFF	OFF
1		OFF	OFF	OFF	OFF	OFF	OFF	ON
2		OFF	OFF	OFF	OFF	OFF	ON	OFF
...								
127		ON	ON	ON	ON	ON	ON	ON

Parity does not need to be set.

The built-in 150ohm EOL termination may be enabled by setting DIP switch 5 to the ON position. EOL termination should only be enabled when the FSKN is the first or last physical device on a network segment.

BACnet object description

Object Name	Object Type [Instance]	Description/Comment	Values	Value Default	COV Increment	COV Increment Default	Access
Device	Device [Inst.Nr]	Object device Device Name: If set to an empty string, default Device name is set to factory settings. Device Instance Number = Device Offset Object + BACnet MAC address (Dip Switches), not writable with Instance Property	0...4194302	-	-	-	-
RelPos	AI [1]	Relative Position in %	0-50-100	-	0.01...100	1	R
AbsPos	AI [2]	Absolute Position in °	0-45-90	-	0.01...65535	1	R
OffsetDeviceID	AV [121]	This value plus the parameterized MAC address (0...127) define the Device Instance Number.	0...4'194'056 (2*22-247)	1000	1.0...1000	1	W

Object Name	Object Type [Instance]	Description/Comment	Values	Default	Access
SummaryStatus	BI[101]	Summary status Note: Summary Status summarizes the state from MI[106], MI[110], MI[111]	0: OK 1: Not OK	-	R
Command	MV[120]	Initiate Function Initiation of actuator functions for service and test, the value goes after the command back to None (1) automatically.	1: None 2: - 3: Test 4: Reset	1	W
InternalActivity	MI[100]	Detailed Status Information Test: Internal Test running, activated by bus	1: None 2: Test	-	R
StatusActuator *	MI[106]	Status Actuator: Mechanical overload due to blocked actuator etc.	1: OK 2: Actuator cannot move	-	R
StatusDevice *	MI 110]	Status Device: Internal Error, Hardware Defect	1: OK 2: 3: InternalError	-	R
StatusTripping *	MI[111]	Status Sensor: Indicates information about the status of the BAE temperature sensor if employed.	1: OK 2: 3: Temperature Sensor triggered	-	R

Access: R=Read, W=Write, C=Commandable with priority array

All Status Information need a reset command to go back to normal operation

Modbus Dip switch settings

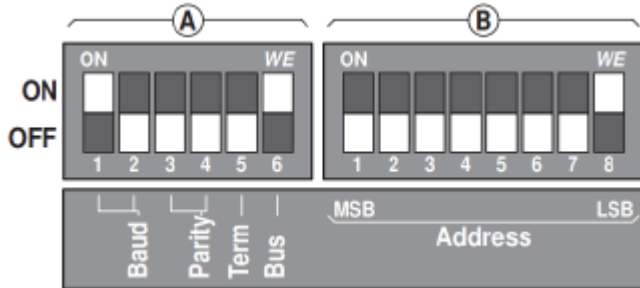

Baud rate	1	2	Parity	3	4	Termination	5	Bus	6
9'600	OFF	OFF	1-8-N-2	OFF	OFF	with 150 Ω	ON	BACnet	ON
19'200	OFF	ON	1-8-N-1	OFF	ON	OFF	OFF	Modbus	OFF
38'400	ON	OFF	1-8-E-1	ON	OFF				
76'800	ON	ON	1-8-O-1	ON	ON				

BACnet address	1	2	3	4	5	6	7	8
0		OFF	OFF	OFF	OFF	OFF	OFF	OFF
1		OFF	OFF	OFF	OFF	OFF	OFF	ON
2		OFF	OFF	OFF	OFF	OFF	ON	OFF
...								
127		ON	ON	ON	ON	ON	ON	ON

Parity does not need to be set.

The built-in 150ohm EOL termination may be enabled by setting DIP switch 5 to the ON position. EOL termination should only be enabled when the FSKN is the first or last physical device on a network segment.

Commands

All data is arranged in a table and addressed by 1..n (register) or 0..n-1 (address). No distinction is made between data types (Discrete Inputs, Coils, Input Registers, Holding Registers). As a consequence, all data can be accessed with the two commands for Holding Register. The commands for Discrete Inputs and Input Registers can be used as an alternative.

Standard commands:

Read Holding Registers [3]

Write Single Register [6]

Optional commands:

Read Discrete Inputs [2]

Read Input Registers [4]

Write Multiple Registers [16]

Note regarding Read Discrete Inputs

The command reads one or more bits and can alternatively be applied for reading the malfunction and service information in Register 105 (Adr 104). The Start address for "BAE (duct temperature sensor) triggered" is calculated with $104 * 16 + 6 = 1670$

Modbus register description

Register 101, 103: Series number

Each node has an unambiguous series number. The series number consists of 4 segments, although only parts 1, 2 and 4 are displayed on Modbus.

Example: 00839-31324-064-008

Register 101	Register 102	Register 103
1st part	2nd part	4th part
00839	31324	008

Register 104: Firmware Version

Firmware Version (VX.XX)

e.g. 201 V2.01

Register 105: Malfunction and service information

The status information is split into messages about the actuator (malfunctions) and other information.

	Bit	Description
Malfunctions (low byte)	0	–
	1	Actuation path increased
	2	Mechanical overload
	3	–
	4	Safety-relevant malfunction
	6	BAE triggered
Service (high byte)	8	Internal activity
	9	–
	12	–
	13	–
	14	–
	15	–

Bit 4: Safety-relevant malfunction – Internal device error – Contact BELIMO

Bit 8: Internal activity – Shows if there is a Test run via Modbus or test button

Register 1 (reserved)

Not used in this device. Constant value 65'535.

Register 2:

Not used

Register 3: Command

Initiation of actuator functions for service and test; the register is reset automatically.

Command

0	None
2	Test run
4	Reset faults

Register 4: Actuator type

Actuator type

3	Fire damper actuator
---	----------------------

Register 5: Relative position

Position in accordance with position indicator switches

- Damper closed: 0 (0%)
- Intermediate switching: 5,000 (50%)
- Damper open: 10,000 (100%)

Register 6:

Not used

Register 9: Collective fault

Fault is set when one of the bits 0...7 of Register 105 is set (used as sensor value for air/water/VAV)

Collective fault

0	no fault
1	fault