





































ZTH-GEN US Label Instructions

ZTH-GEN US	AC/DC 24V	 Supply
Type: MFT, LON; MP	Communication is PP only	
Configuration	Press  while connecting the power	
 	Actuator Model min XX%   to change,  to set max XX%   to change,  to set Run.time XXs   to change,  to set	
	Ctl (Control Signal)   to select  to set if DC variable is selected new start XXV   ,  to set new stop XXV   ,  to set	
	Fb. U5 (Feedback)   to select  to set if DC variable is selected new start XXV   ,  to set new stop XXV   ,  to set	
	Actual Value XX%  to close  to open address PP  to change to MPX Messages Start PICCV Process  for YES,  for NO	
	VAV + PICCV Programming - see instructions	

The ZTH-GEN is a tool created to easily adapt the flow settings for the ePIV in the field. It directly connects to the Belimo actuator.

CONNECTION PROCESS:



AR, GR, AK, GK Series

Use the interface on the top of the actuator. (Leave all of the wires of the actuator installed.)



Technical Information

Supply	24 VAC/DC
Communication	PP
Used with actuator types	ARB24 GRB24 AKRB24 GKRB24

RE-PROGRAMMING PROCESS:

Initial Screen

Connect cable to actuator port, twist to lock in place. Will display the handheld software and hardware versions for 5 seconds then it will display the actuator being connected

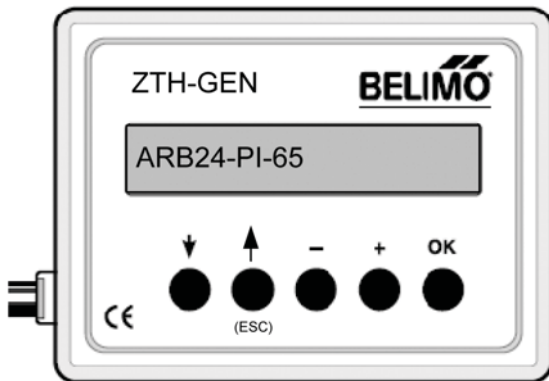

Screen 1

Start ePIV process by pressing the up arrow (ESC) The first screen displays the MFT address, press ESC to continue to the next screen.

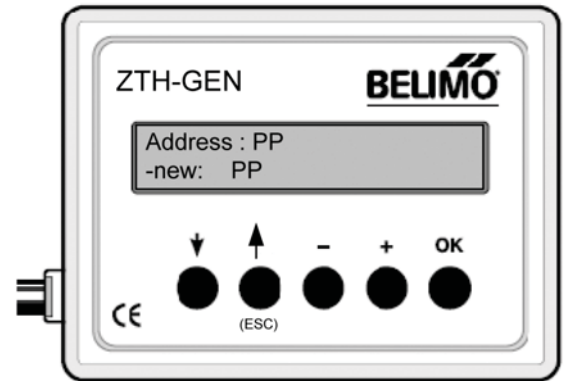

07/10 - Subject to change. © Belimo Aircontrols (USA), Inc.

Screen 2

To change the Vmax value press the – button until you reach the required value then press the OK button.

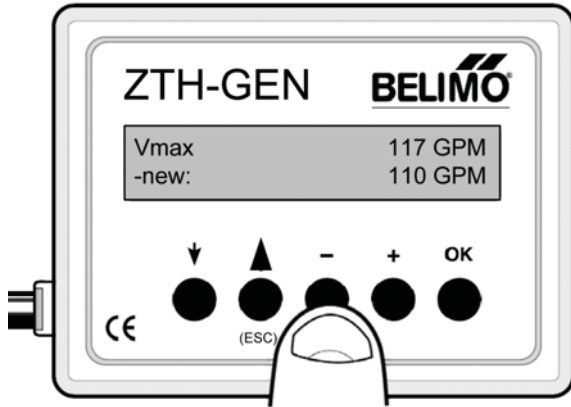

Screen 3

A message is displayed “Y and U5 Adjusted” for 5 seconds. Then the new Vmax value is displayed. Press ESC to continue to the next screen or simply disconnect the device from the actuator.

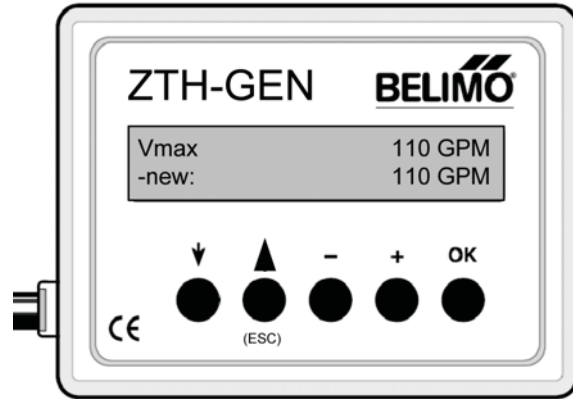

Screen 4

Press the +/- buttons to select different override commands, once selected press OK to execute.

- AUTO: Automatic Operation
- OPEN: Overrides the valve to the maximum aperture (90°)
- CLOSE: Overrides the valve to minimum aperture (0°)
- Vmax: Overrides the valve to its maximum GPM
- STOP: Overrides the valve to the last valve position

Note: the override remains active even after you disconnect the ZTH-GEN, it is released using the AUTO command or cycling power on the actuator.

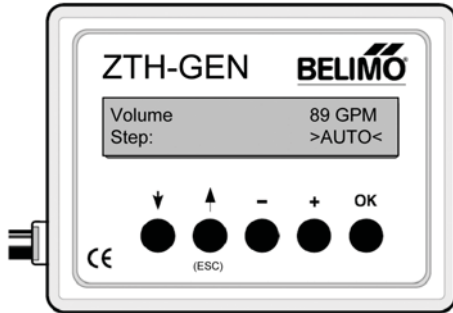

Screen 5

This screen displays the current GPM and valve position. This is used for troubleshooting. A small valve position and big GPM reading might indicate overpressure in the system. A small flow and a big valve position might indicate that there is not enough flow or pressure in the system

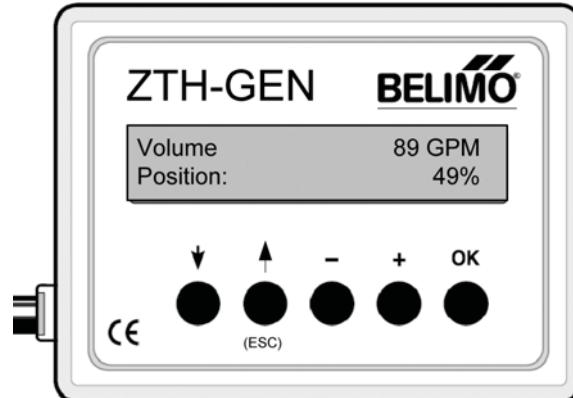

Screen 6

This screen displays the current GPM and the setpoint send by the controller. The voltage signal is converted to GPM in the actuator. This can be used to troubleshooting to verify the signal send by the controller and to verify Setpoint vs. Actual flow.

