



8 reasons
for the use of
butterfly valves.

Butterfly valves from Belimo

BELIMO[®]

Energy-efficient solutions with easy commissioning.



With the development of the new generation of butterfly valves and actuators, Belimo has succeeded in bringing a further innovation to the market. Firstly, butterfly valves from Belimo are very flexible in terms of possible implementation, as they can be used for isolation, changeover, and control applications. Furthermore, our actuators and butterfly valves are optimally matched to one another, which means they are absolutely tight and energy-saving. This matching makes it possible to utilise a smaller actuator, which results in significantly reduced weight and installation height. Communication is highly transparent thanks to NFC, analogue or bus communication. With the Belimo Assistant app, the butterfly valves can be commissioned and parameterised very quickly. Additionally, the diagnostic function guarantees optimal operation. The PRK fail-safe actuator guarantees high operating safety.



Video – Butterfly valves for control applications

Content.

- 1 Flexible field applications**
- 2 Absolute tightness**
- 3 Energy-saving design**
- 4 Reduced weight and construction height**
- 5 Transparent communication**
- 6 Seamless sensor integration**
- 7 High operating safety**
- 8 Fit for reliable control tasks**

1. Flexible field applications.

One solution for all applications

In contrast to globe valves, butterfly control valves are intended for universal use in control, isolation and changeover applications.

While the direction of flow has to be considered when installing a globe valve, butterfly valves can be installed in any orientation in the pipeline. A 3-way butterfly valve can also be installed in any configuration at a T-piece for universal use in changeover and control applications.

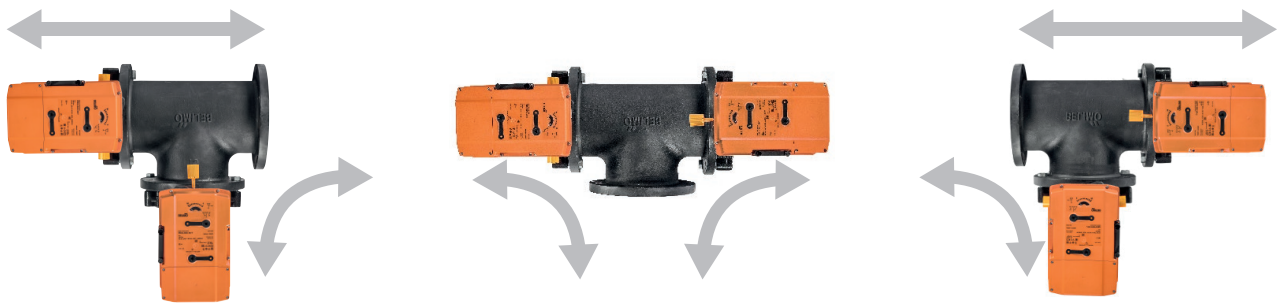

Butterfly valves installed in any configuration at a T-piece, according to the application.

Globe valves can only be used to divert with a specialised spindle design. However, a 3-way butterfly valve can be used as a mixing valve as well as a diverting valve without any such limitations.

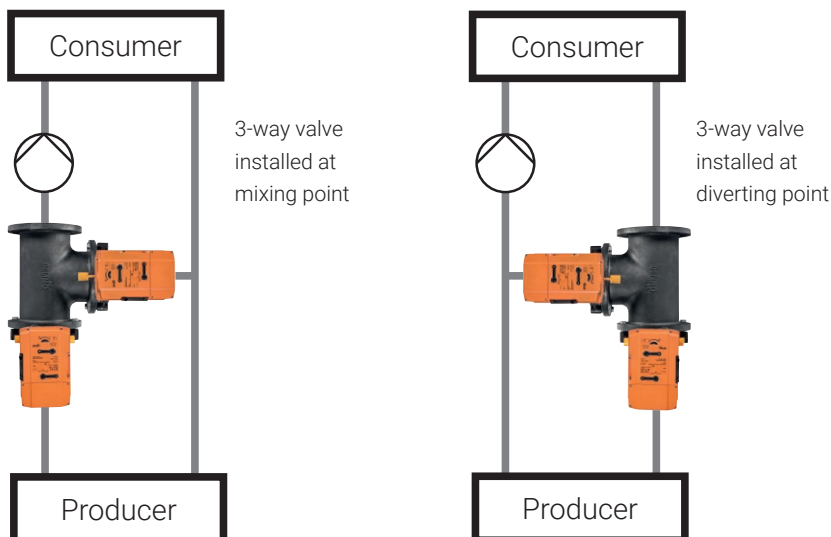

2. Absolute tightness.

No leakage due to butterfly valve design

The unique valve design reliably prevents internal leakage in the closed state and thus inadvertent consumption with zero load. The heating or cooling energy requirement is reduced as a result. In the case of globe valves, the amount of leakage water also increases along with the nominal diameter. In the case of butterfly valves, however, this remains constant at zero (leakage rate A, tight), independent of the nominal diameter. In this way, butterfly valves reduce energy consumption and significantly decrease operating costs.

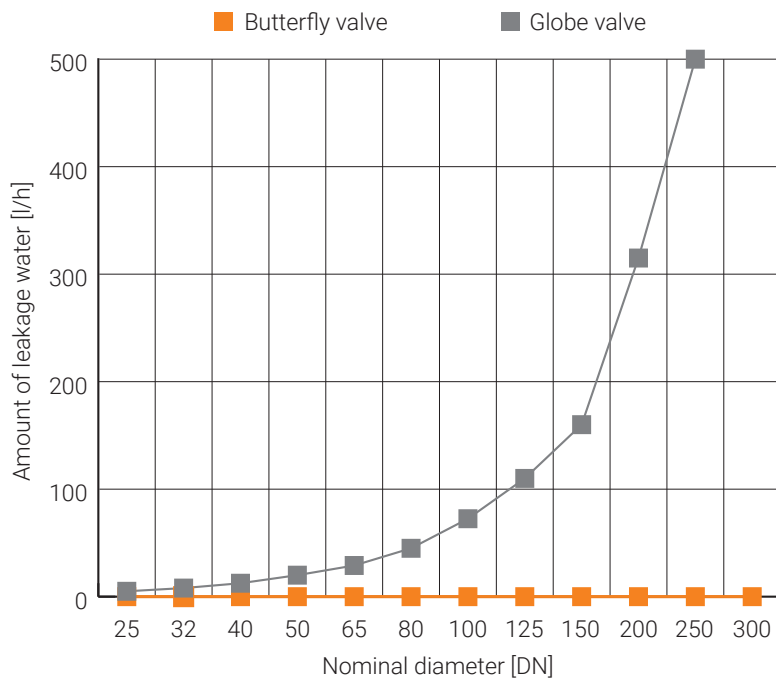

Comparisons of leakage volumes (m^3/h) at $\Delta p = 1$ bar in the nominal diameters DN 25...300.

3. Energy-saving design.

Innovative technology

The power consumption of an actuator appears to be negligible at first glance. However, a considerable potential for energy savings exists when the entire life cycle is taken into account.

A direct comparison of the power consumption of PR actuators and comparable globe valve actuators reveals a reduction in power consumption of more than 50 percent.

The following three areas were optimised in the butterfly control valve design process:

- Optimised contact surface between disk and rubber seal
- Reduced contact surface in the shaft area
- Friction-optimised bearings and bushings

Torque-optimised butterfly valve design

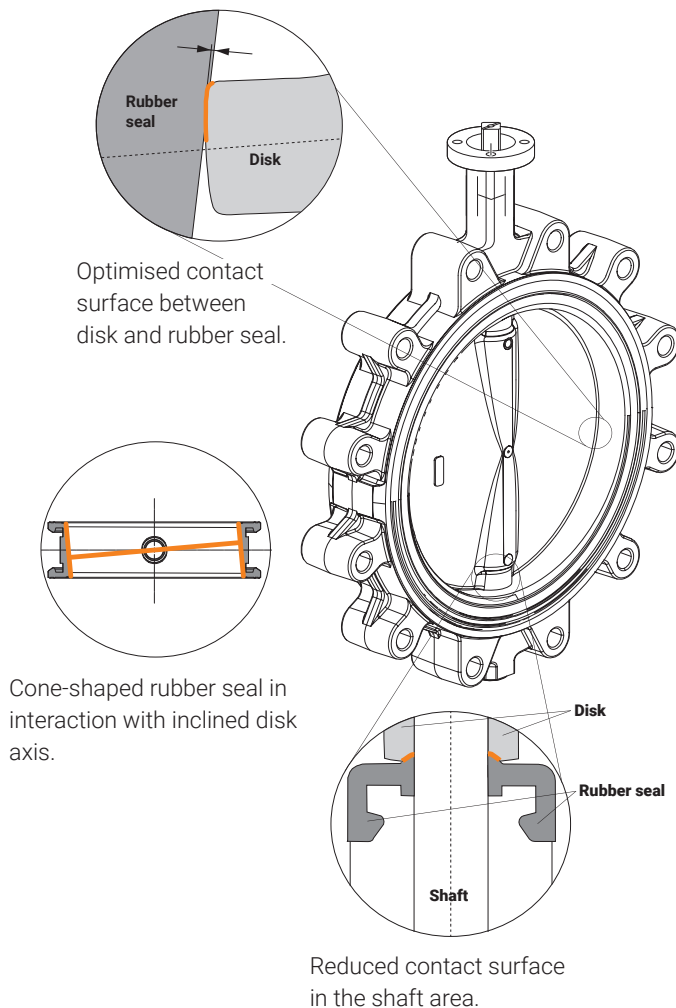

Energy-saving actuator and valve design

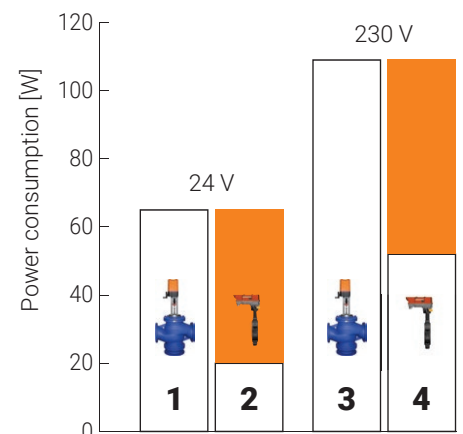

- 1 Globe valve actuator for 24 V
- 2 Butterfly valve actuator for 24 V
- 3 Globe valve actuator for 230 V
- 4 Butterfly valve actuator for 230 V

■ Energy Savings

4. Reduced weight and construction height.

A great advantage of the new generation

Through actuator optimisation and harmonisation with valve design, Belimo has succeeded in greatly reducing the size and weight of its actuators. This facilitates installation, as the lightweight 6 kg actuator is simple to mount. As a result of the reduced height, the space requirement is also less, thus leading to greater flexibility in both planning and installation.



2-way butterfly valve compared to a 2-way globe valve.



3-way butterfly valve compared to a 3-way globe valve.

5. Transparent communication.

Simple parametrisation of communication protocols

The fact that the butterfly valve actuator is communicative means that it offers several advantages in terms of commissioning and maintenance.

These advantages start as early as the planning stages. The butterfly valve actuator can be parameterised flexibly by smartphone, which makes planning considerably easier by allowing the user to forgo early decisions about the input signal. The butterfly valve actuator can be configurable as open/close, 3-point, 0.5...10 V, 2...10 V, 4...20 mA, Belimo MP-Bus, Modbus RTU and BACnet MS/TP, even when the actuator is not connected to the power supply. With the commissioning workflow for our communicative actuators, application-dependent, predefined settings can be selected easily and quickly and then written to the actuator. This allows error-free parametrisation, saves time and money during commissioning and ensures optimal use of the butterfly control valves from Belimo.



Simple commissioning directly via smartphone or the Bluetooth-NFC converter ZIP-BT-NFC using Near Field Communication (NFC).

6. Seamless sensor integration.

Seamlessly integrated temperature measurement

Temperature sensors can be easily connected to the communicative JR and PR actuators to create an optimised system. Two measurement inputs for active and passive sensors provide precise measurement data via BACnet MS/TP or Modbus RTU.

The following temperature sensors from Belimo of the type 01DT are compatible with communicative PR actuators:

- Pt1000
- Ni1000
- NTC10K

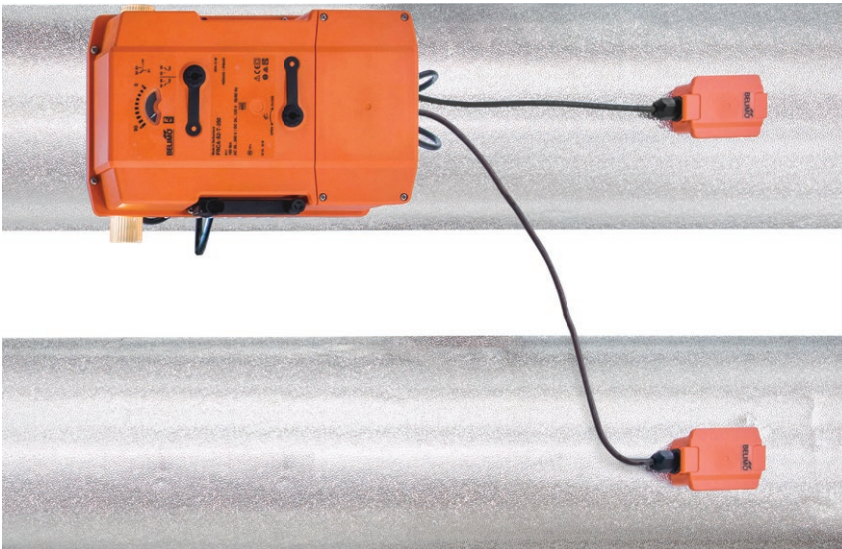

7. High operating safety.

Protected housing

Thanks to its IP66/67 degree of protection, the actuator is suitable for outdoor usage and is protected against UV radiation, rain, snow, dirt, dust and humidity.

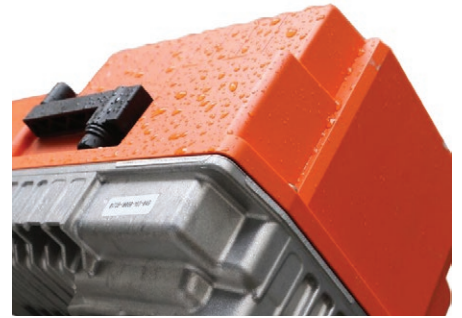

Thermal insulation and smart heating

The linkage between actuator and butterfly valve fulfills the function of a thermal insulation and, like the built-in intelligent heating, prevents condensation in the actuator. Thanks to an integrated temperature and humidity sensor, it switches itself on only when ambient conditions require it to do so, thus saving energy.



High level of safety even during power failures

Thanks to its fail-safe, the reliable PRK actuator enables high operating safety for the installation. The butterfly valve moves to its specified position in the event of a power failure.



8. Fit for reliable control tasks.

Teaching the butterfly valve how to control

Thanks to the clever interaction between the innovative butterfly valves from Belimo and the intelligent JR and PR actuators, Belimo has taught butterfly valves in nominal sizes DN 100...300 precise control with selectable equal-percentage or linear characteristic curves. Parameterisation of the characteristic curve can be accomplished very simply with the Belimo Assistant App via NFC.

To achieve a linear characteristic curve with a butterfly valve, the S-shaped valve characteristic curve typical for butterfly valves must be corrected. The opening angle must be adjusted according to the specified control signal to achieve the desired flow rate. The intelligent actuators of the butterfly control valves from Belimo make this possible by automatically adjusting the control angle and moving the valve to the required position. This reliably ensures a linear characteristic curve and smooth control characteristics.

In addition, the Belimo Assistant App can be used for flexible adjustment of the maximum opening angle of the valve (its max. position) and thereby also the K_{vs} value of the butterfly control valve for perfect matching with the respective application.

The 3-way control valve – redefined

The 3-way butterfly control valve from Belimo is comprised of two 2-way butterfly control valves with linearly parametrised characteristic curves. Both butterfly control valves can be controlled with the same control signal; only one of the two butterfly control valves must be parametrised in such a way that it processes the control signal in an inverted fashion. Thanks to the parametrisable linear characteristic curve of the two 2-way butterfly control valves, a perfect mixing characteristic curve results from their interaction as a 3-way butterfly control valve.

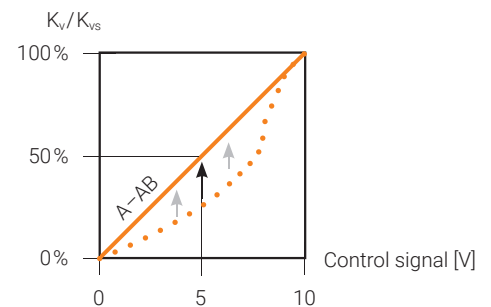

A butterfly control valve with a linearised characteristic curve thanks to the intelligent actuator, parametrisable with the Belimo Assistant App.

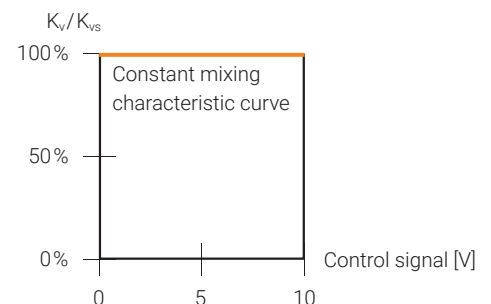
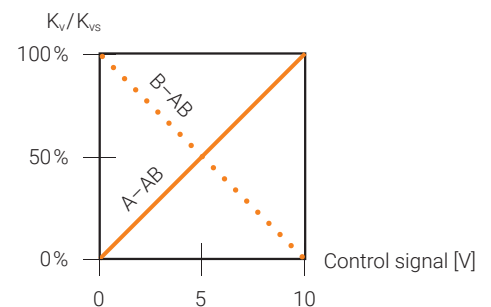

The linear characteristic curve in the control path and the inverse linear characteristic curve in the bypass yield a constant mixing characteristic curve.

All inclusive.

Belimo as a global market leader develops innovative solutions for the controlling of heating, ventilation and air-conditioning systems. Damper actuators, control valves, sensors and meters represent our core business.

Always focusing on customer value, we deliver more than only products. We offer you the complete product range for the regulation and control of HVAC systems from a single source. At the same time, we rely on tested Swiss quality with a five-year warranty. Our worldwide representatives in over 80 countries guarantee short delivery times and comprehensive support through the entire product life. Belimo does indeed include everything.

The "small" Belimo devices have a big impact on comfort, energy efficiency, safety, installation and maintenance.

In short: Small devices, big impact.



5-year warranty



On site around the globe



Complete product range



Tested quality



Short delivery times



Comprehensive support

