

Butterfly Valve with

- Disc 304 stainless steel (CF-8, 1.4308)



5-year warranty

Picture may differ from product

Type overview

Type	DN	Cv	Body Pressure Rating
F6125L	5" [125]	1140	ANSI Class Consistent with 125, 232 psi CWP

Technical data

Functional data	Valve size [mm]	5" [125]
	Fluid	Chilled and hot water, water with glycol up to max. 60% vol.
	Fluid temperature	-22...250°F [-30...120°C]
	Close-off pressure	Δp_s 200 psi
	Flow characteristic	equal percentage
	Pipe connection	Flange for use with ASME/ANSI class 125/150
	Servicing	maintenance-free
	Flow Pattern	2-way
	Controllable flow range	90° rotation
	Maximum Velocity	12 FPS
	Lug threads	3/4-10 UNC
	Materials	Valve body
Stem		Stainless steel AISI 420 (1.4021)
Stem seal		EPDM O-ring
Stem bearing		Bronze, steel, PTFE
Seat		EPDM
Disc		304 stainless steel (CF-8, 1.4308)

Dimensions

Type	DN	Weight
F6125L	5" [125]	21.7 lb [9.8 kg]

Dimensions

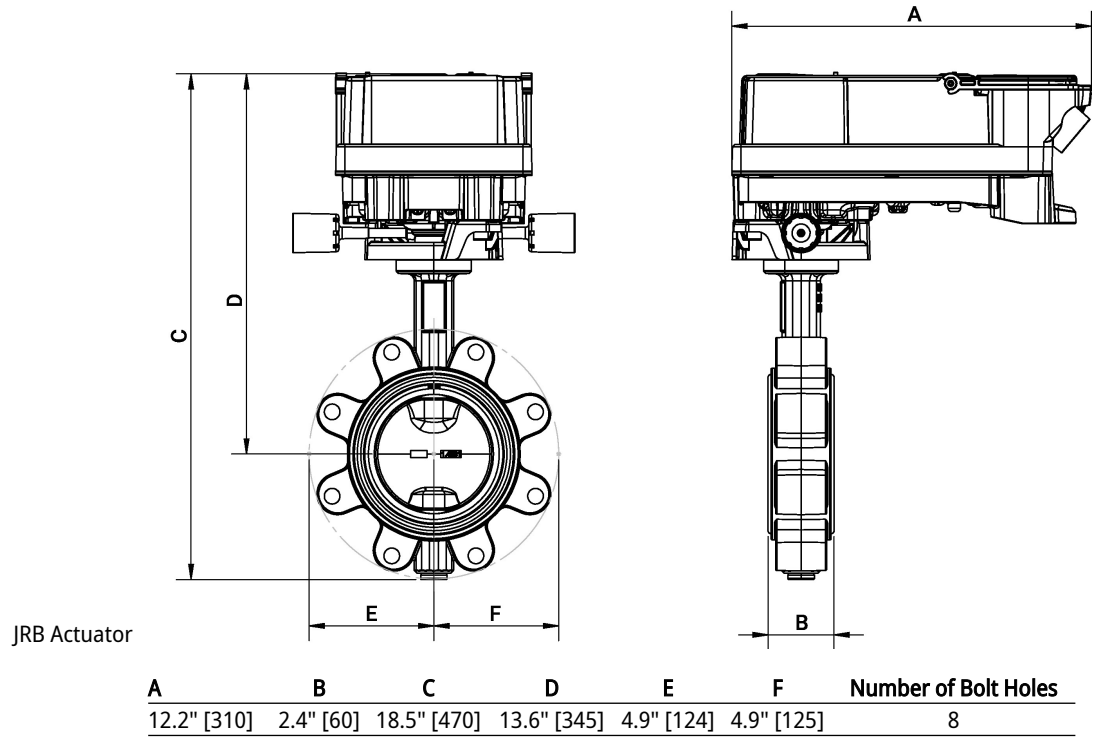

Further documentation

- The complete product range for water applications
- Data sheets for actuators
- Installation instructions for actuators and/or butterfly valves
- General notes for project planning

Rotary actuator for butterfly valves

- Nominal voltage AC 24...240 V / DC 24...125 V
- Control Modulating, Communicative, Hybrid
- With two integrated auxiliary switches
- Conversion of sensor signals
- Communication via BACnet MS/TP, Modbus RTU, Belimo-MP-Bus or conventional control



Picture may differ from product



5-year warranty

Technical data

Electrical data	Nominal voltage	AC 24...240 V / DC 24...125 V
	Nominal voltage frequency	50/60 Hz
	Nominal voltage range	AC 19.2...264 V / DC 19.2...137.5 V
	Power consumption in operation	20 W
	Power consumption in rest position	7 W
	Transformer sizing	with 24 V 20 VA / with 240 V 55 VA
	Auxiliary switch	2x SPDT, 1x 10° / 1x 0...90° (default setting 85°)
	Switching capacity auxiliary switch	1 mA...3 A (0.5 A inductive), DC 5 V...AC 250 V
	Connection protective earth	20 ... 14 AWG, only copper wires
	Connection control	22 ... 16 AWG, only copper wires (class 2 supply / SELV)
	Electrical Connection	Terminal blocks, (PE) Ground-Screw
	Overload Protection	electronic throughout 0...90° rotation
	Data bus communication	Communicative control
Number of nodes		BACnet / Modbus see interface description MP-Bus max. 16
Functional data	Position accuracy	±5%
	Manual override	hand lever
	Running Time (Motor)	35 s / 90°
	Running time motor variable	20...120 s
	Sound power level, motor	65 dB(A)
	Position indication	Mechanical, integrated
Safety data	Power source UL	Class 2 Supply
	Degree of protection IEC/EN	IP66/67
	Degree of protection NEMA/UL	NEMA 4X
	Housing	UL Enclosure Type 4X
	EMC	CE according to 2014/30/EU
	Low voltage directive	CE according to 2014/35/EU
Certification IEC/EN	IEC/EN 60730-1 and IEC/EN 60730-2-14	

Technical data

Safety data	UL Approval	cULus according to UL60730-1A, UL60730-2-14 and CAN/CSA E60730-1 The UL marking on the actuator depends on the production site, the device is UL-compliant in any case
	Overvoltage category	III
	Ambient humidity	Max. 100% RH
	Ambient temperature	-22...122°F [-30...50°C]
	Storage temperature	-40...176°F [-40...80°C]
	Software Class	A
	Servicing	maintenance-free
Mechanical data	Connection flange	F07 (F05 only with accessory)
Weight	Weight	8.1 lb [3.7 kg]

Safety notes

- This device has been designed for use in stationary heating, ventilation and air-conditioning systems and must not be used outside the specified field of application, especially in aircraft or in any other airborne means of transport.
- Caution: Line voltage!
- The device has a protective earthing. Incorrect connection of the protective earth can lead to hazards due to electrical shock.
- Only authorized specialists may carry out installation. All applicable legal or institutional installation regulations must be complied with during installation.
- Apart from the wiring compartment, the device may be opened only at the manufacturer's site. It does not contain any parts that can be replaced or repaired by the user.
- The device contains electrical and electronic components and must not be disposed of as household refuse. All locally valid regulations and requirements must be observed.
- The two switches integrated in the actuator are to be operated either on line voltage or on safety extra-low voltage. The combination line voltage/safety extra-low voltage is not permitted.
- For maintenance work, the correct valve position must be set via the control signal. Additionally, the actuator must be disconnected from the power source. The hand crank and manual override shall not be used as a safety measure to maintain the valve position.

Product features

Fields of application	The actuator is particularly suitable for utilisation in outdoor applications and is protected against the following weather conditions: - UV radiation - Dirt / Dust - Rain / Snow - Air humidity
Converter for sensors	Connection option for two sensors (passive, active or switching contacts). In this way, the analog sensor signal can be easily digitized and transferred to the bus systems BACnet or Modbus.
Internal heating	An internal heater prevents condensation buildup. Thanks to the integrated temperature and humidity sensor, the built-in heater automatically switches on/off.
Configurable Device	The factory settings cover the most common applications. Belimo Assistant 2 is required for configuration via Near Field Communication (NFC) and simplifies commissioning. Moreover, Belimo Assistant 2 provides a variety of diagnostic options. The ZTH EU service tool provides a selection of both diagnostic and setting options.

Product features

Combination analogue - communicative (hybrid mode)	With conventional control by means of an analogue control signal, BACnet or Modbus can be used for the communicative position feedback
Simple direct mounting	Simple direct mounting on the butterfly valve. The mounting orientation in relation to the butterfly valve can be selected in 90° (angle) increments.
Manual override	The valve can be manually operated using a hand crank. Unlocking is carried out manually by removing the hand crank.
High functional reliability	The actuator is overload protected, requires no limit switches and automatically stops when the end stop is reached.
Innovative motorization	The actuator uses the powerful Belimo M600 microchip in combination with the INFORM method. It provides the full starting torque from a standstill with high precision (sensorless INFORM-Drive by Prof. Schrödl).
Flexible signaling	The actuator has one auxiliary switch with a fixed setting (10°) and one adjustable auxiliary switch (0...90°).

Accessories

Tools	Description	Type
	Service tool for wired and wireless setup, on-site operation and troubleshooting.	Belimo Assistant 2
	Universal converter, with ZIP-USB function and Bluetooth to NFC conversion, for wired and wireless connection of the device to PC/tablet/smartphone	Belimo One Tool
	Connecting cable 16 ft [5 m], A: RJ11 6/4 LINK.10, B: 6-pin for connection to service socket	ZK1-GEN
Mechanical accessories	Description	Type
	Hand crank for JR actuator	ZJR20

Electrical installation

Caution: Line voltage!

Parallel connection of other actuators possible. Observe the performance data.

The wiring of the line for BACnet MS/TP / Modbus RTU is to be carried out in accordance with applicable RS485 regulations.

AC 24...240 V / DC 24...125 V

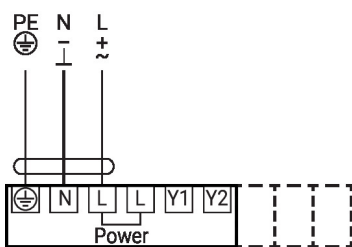

Modulating control

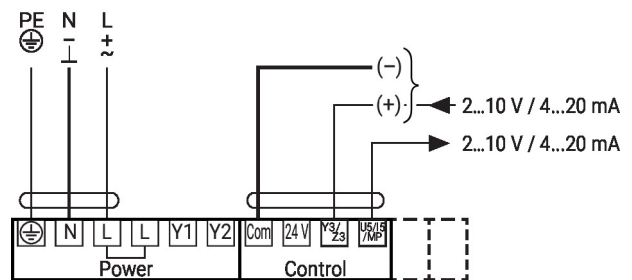

Auxiliary switch

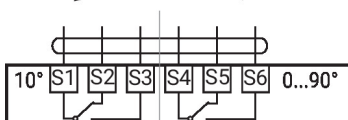
~~230 V + 230 V~~
~~24 V + 24 V~~
~~230 V + 24 V~~
~~24 V + 230 V~~

Electrical installation

Connection BACnet MS/TP / Modbus RTU

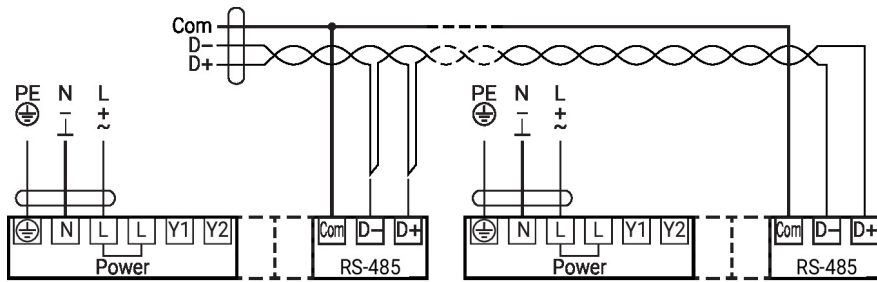

Converter for sensors

Connection of passive sensors (BACnet MS/TP / Modbus RTU / MP-Bus)

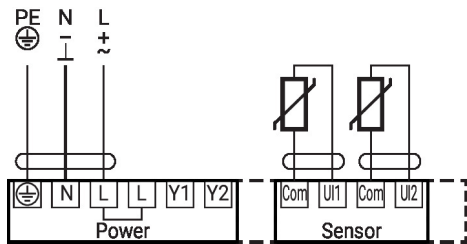

1)	2)
500 Ω...2 kΩ	+/-1%
2 kΩ...10 kΩ	+/-2%
10 kΩ...55 kΩ	+/-6%

- 1) Resistance range
- 2) Tolerance measured value
- Compensation of the measured value is recommended
- Suitable for Ni1000 and Pt1000
- Suitable Belimo types 01DT--

Switching contact connection (BACnet MS/TP / Modbus RTU / MP-Bus)

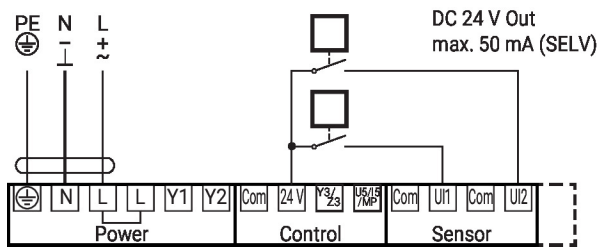

Switching contact requirements:
 The switching contact must be able to switch a current of 10 mA at 24 V accurately.
 To capture, for example:
 - Flow monitors
 - Operation/malfunction messages of chillers

Connection of active sensors (BACnet MS/TP / Modbus RTU / MP-Bus)

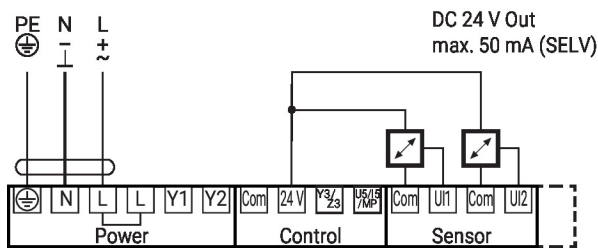

Possible input voltage range:
 0...10 V
 Resolution 5 mV
 To capture, for example:
 - Active temperature sensors
 - Flow sensors
 - Pressure/differential pressure sensors

Further electrical installations

Functions with basic values (conventional mode)

Connection on the MP-Bus

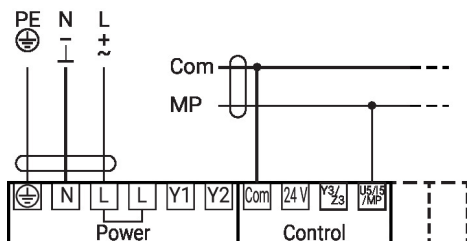

Further electrical installations

Functions with specific parameters (configuration necessary)

Control on/off

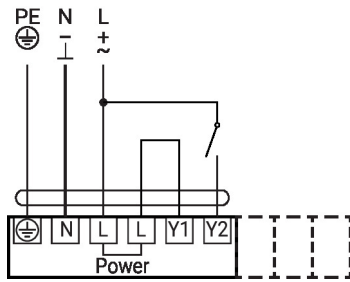

Control on/off

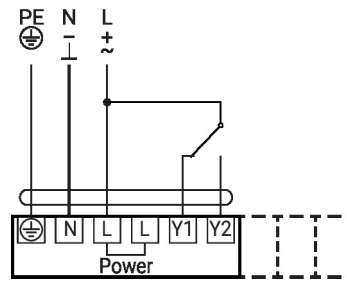

Control floating point

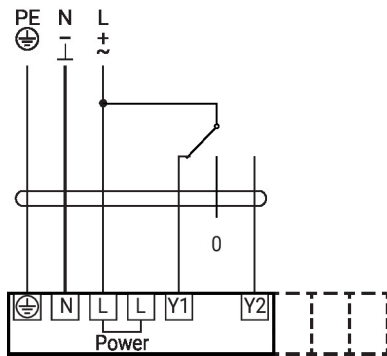

Connection BACnet MS/TP / Modbus RTU with analog setpoint (hybrid mode)

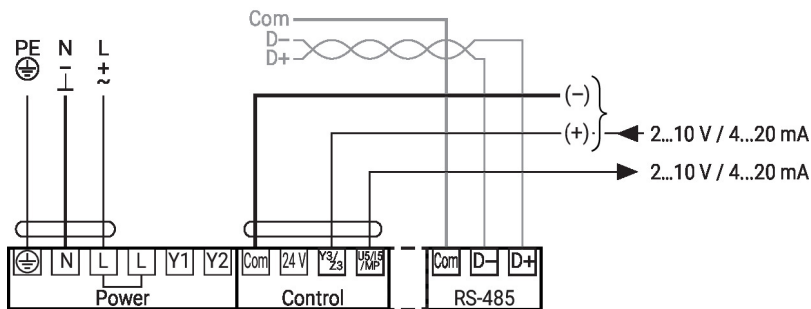

Operating controls and indicators

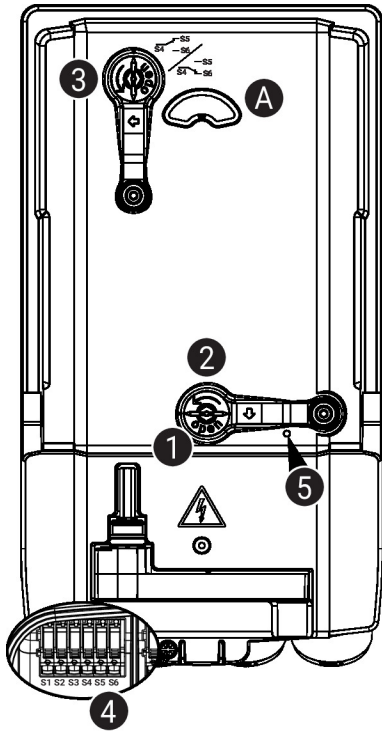

5 LED display green

- Off: No power supply or malfunction
- On: In operation

Auxiliary switch settings



Note: Perform settings on the actuator only in deenergised state.

For the auxiliary switch position settings, carry out points **1** to **4** successively.

1 Gear train disengagement

Opening the manual override cover and adjusting the hand crank. Manual override is possible.

2 Manual override

Turn the hand crank until the desired switching position **A** is indicated and then remove the hand crank.

3 Auxiliary switch

For the auxiliary switch position settings, carry out points **1** to **4** successively.

Opening the auxiliary switch adjustment cover and adjusting the hand crank. Turn the hand crank until the arrow points to the line.

4 Terminals

Connect continuity tester to S4 + S5 or to S4 + S6.

If the auxiliary switch should switch in the opposite direction, rotate the hand crank by 180°.

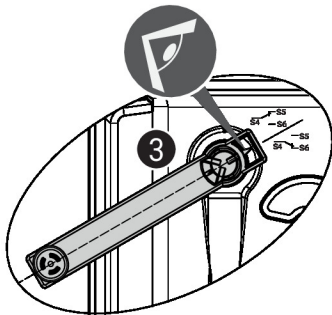

Service

Wireless connection Belimo devices marked with the NFC logo can be operated with the Belimo Assistant 2.

Requirement:

- NFC- or Bluetooth-capable smartphone
- Belimo Assistant 2 (Google Play and Apple App Store)

Align NFC-capable smartphone on the device so that both NFC antennas are superposed.

Connect Bluetooth-enabled smartphone via the Bluetooth-to-NFC converter ZIP-BT-NFC to the device. Technical data and operating instructions are shown in the ZIP-BT-NFC data sheet.

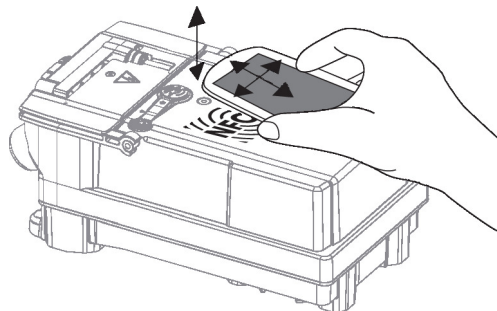

Service

Wired connection The Belimo One Tool can configure the actuator via the service socket.

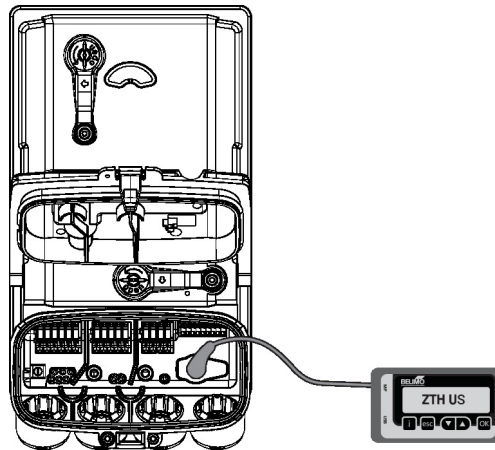

Dimensions

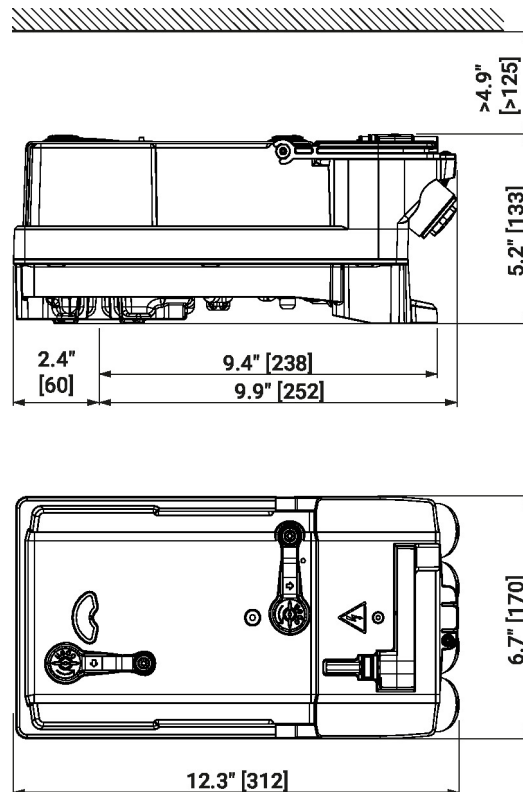

Further documentation

- Tool connections
- BACnet Interface description
- Modbus Interface description
- Overview MP Cooperation Partners
- Introduction to MP-Bus Technology
- MP Glossary
- The complete product range for water applications
- Data sheets for butterfly valves
- Installation instructions for actuators and/or butterfly valves
- General notes for project planning
- Quick Guide – Belimo Assistant 2