

**ZoneTight™, 2-way, Sweat**

- For closed cold and warm water systems
- For switching functions and 2-point controls on the water side of air-handling units and heating systems
- Snap-assembly of the actuator



5-year warranty

**Type overview**

<b>Type</b>	<b>DN</b>
Z2050QS-F	15

**Technical data**

<b>Functional data</b>	Valve size [mm]	0.5" [15]
	Fluid	chilled or hot water, up to 60% glycol
	Fluid Temp Range (water)	36...212°F [2...100°C]
	Body Pressure Rating	360 psi
	Close-off pressure Δps	75 psi
	Differential pressure Δpmax	40psi
	Flow characteristic	equal percentage
	Leakage rate	0%
	Angle of rotation note	Operating range 15...90°
	Pipe connection	Sweat
	Installation orientation	upright to horizontal (in relation to the stem)
	Servicing	maintenance-free
	Flow Pattern	2-way
	Controllable flow range	75°
	Cv	1.2
<b>Materials</b>	Valve body	forged brass
	Stem	brass
	Stem seal	EPDM O-ring
	Seat	PTFE, O-Ring EPDM
	O-ring	EPDM (lubricated)
	Ball	chrome plated brass
<b>Suitable actuators</b>	Non Fail-Safe	CQB(X)
	Electrical fail-safe	CQKB(X)

**Safety notes**



- **WARNING:** This product can expose you to lead which is known to the State of California to cause cancer and reproductive harm. For more information go to [www.p65warnings.ca.gov](http://www.p65warnings.ca.gov)
- If temperature exceeds 212°F operating range due to a boiler control failure the valve will safely contain the hot water but manufacturers product warranty becomes invalid. Valve and actuator replacement is at the expense of others.

## Product features

- Application** The QCV zone valves are suited for large commercial buildings where higher close-off and the ability to change flow is desired. Common applications include unit ventilators, fan coil units, VAV reheat coils, fin tube casing, radiant panels and duct coils. The valve fits in space restricted areas and can be assembled without the use of tools.
- Operating mode** The ball valve is adjusted by a rotary actuator. The rotary actuator is controlled by an on/off signal or by a commercially available modulating or floating point control system and moves the ball of the ball valve – the throttling device – to the position preset by the control signal. Open the ball valve is carried out counterclockwise and close it clockwise.
- Simple direct mounting** Tool-free snap assembly.  
The actuator can be plugged on the valve by hand (Caution! Just vertical movements). Pins must match the holes on the flange.  
The mounting orientation in relation to the valve can be selected in 180° increments. (Possible two times)

## Installation notes

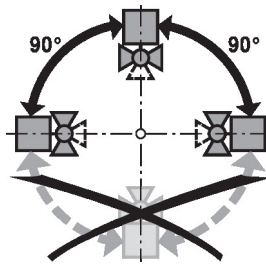
- Permissible installation orientation** The ball valve can be installed upright to horizontal. The ball valve may not be installed in a hanging position, i.e. with the stem pointing downwards.



- Water quality requirements** Belimo valves are regulating devices. For the valves to function correctly in the long term, they must be kept free from particle debris (e.g. welding beads during installation work). The installation of a suitable strainer is recommended.

- Servicing** Ball valves and rotary actuators are maintenance-free.  
Before any service work on the control element is carried out, it is essential to isolate the rotary actuator from the power supply (by unplugging the electrical cable if necessary). Any pumps in the part of the piping system concerned must also be switched off and the appropriate slide valves closed (allow all components to cool down first if necessary and always reduce the system pressure to ambient pressure level).  
The system must not be returned to service until the ball valve and the rotary actuator have been correctly reassembled in accordance with the instructions and the pipeline has been refilled by professionally trained personnel.

- Flow direction** Direction of flow in both directions possible.

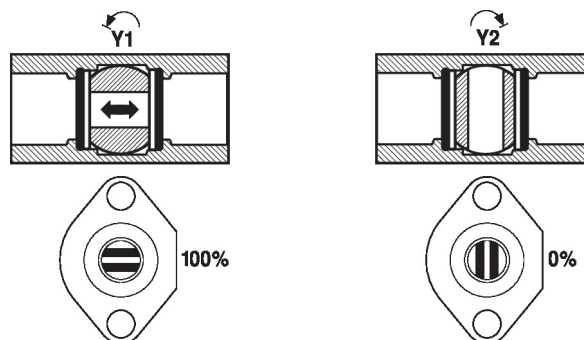

Installation notes

**Flow setting** The angle of rotation of the actuator can be changed by a clip in 2.5° increments. This is used to set the kvs value (maximum flow rate of the valve).

Remove end stop clip and place at desired position.

After every change of the flow setting by means of end stop clip, an adaptation must be triggered on the modulating actuators.

Dimensions

Type	DN	Weight
Z2050QS-F	15	2.9 lb [1.3 kg]

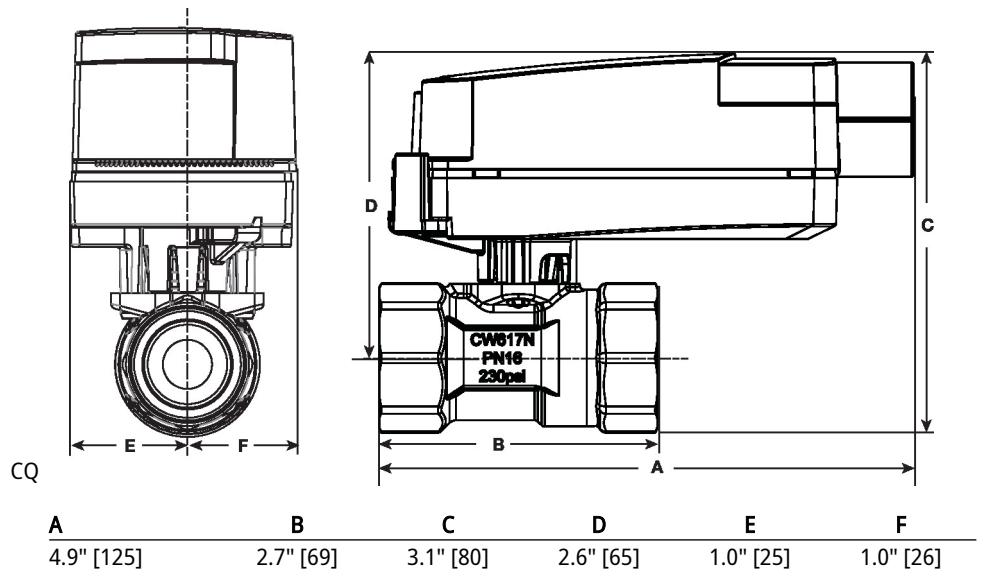
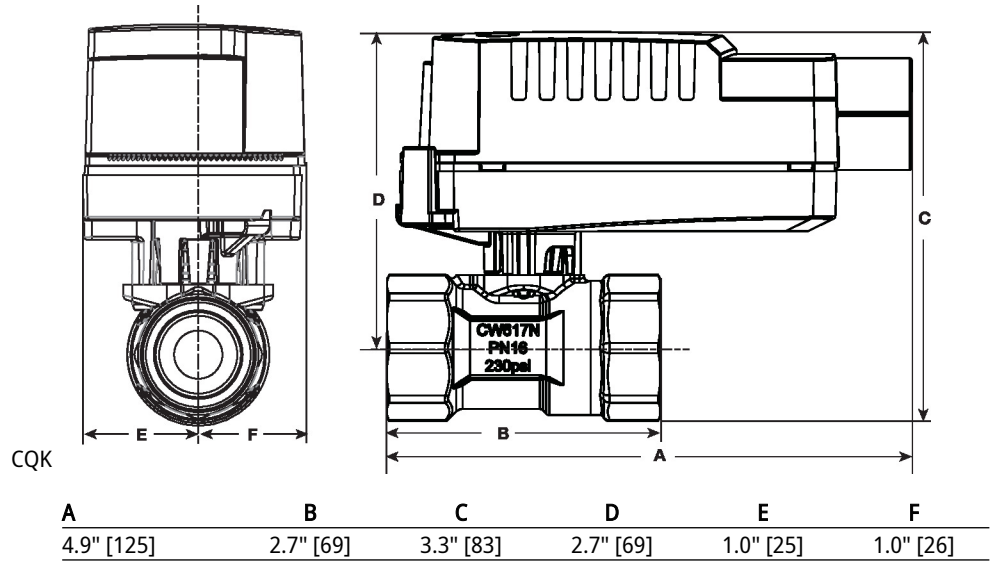

Modulating, Non fail-safe, 24 V

- Nominal voltage AC/DC 24 V
- Control Modulating 2...10 V

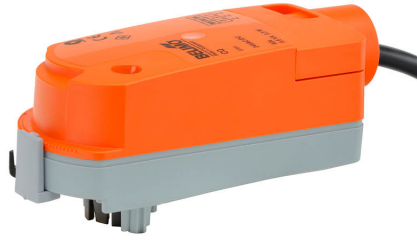

5-year warranty



## Technical data

<b>Electrical data</b>	Nominal voltage	AC/DC 24 V	
	Nominal voltage frequency	50/60 Hz	
	Nominal voltage range	AC 19.2...28.8 V / DC 21.6...28.8 V	
	Power consumption in operation	0.3 W	
	Power consumption in rest position	0.3 W	
	Transformer sizing	1 VA	
	Electrical Connection	22 GA plenum cable, 3 ft [1 m], with 1/2" NPT conduit connector	
	Overload Protection	electronic throughout 0...90° rotation	
	Electrical Protection	actuators are double insulated	
<b>Functional data</b>	Operating range Y	2...10 V	
	Operating range Y note	4...20 mA w/ ZG-R01 (500 Ω, 1/4 W resistor)	
	Position feedback U	2...10 V	
	Angle of rotation	90°	
	Angle of rotation note	adjustable with mechanical stop	
	Running Time (Motor)	75 s / 90°	
	Noise level, motor	35 dB(A)	
	Position indication	pointer	
	<b>Safety data</b>	Power source UL	Class 2 Supply
Degree of protection IEC/EN		IP40	
Degree of protection NEMA/UL		NEMA 2	
Enclosure		UL Enclosure Type 2	
Agency Listing		cULus acc. to UL60730-1A/-2-14, CAN/CSA E60730-1:02 CE acc. to 2014/30/EU and 2014/35/EU	
Quality Standard		ISO 9001	
UL 2043 Compliant		Suitable for use in air plenums per Section 300.22(C) of the NEC and Section 602 of the IMC	
Ambient humidity		Max. 95% RH, non-condensing	
Ambient temperature		35...104°F [2...40°C]	
Storage temperature		-40...176°F [-40...80°C]	
Servicing		maintenance-free	
<b>Weight</b>		Weight	0.55 lb [0.25 kg]
		<b>Materials</b>	Housing material
		UL94-5VA	

Technical data

Product features

**Application** Non-Fail Safe proportional ZoneTight actuator.  
 Valve selection should be in accordance with flow parameters and system specifications.  
 The actuator is mounted directly to the valve without the need for tools or additional linkage.  
 The actuator operated in response to a 2...10 V, 0.5...10 V, or 4...20 mA control signal.

Electrical installation

**INSTALLATION NOTES**

- 2** Actuators may be connected in parallel. Power consumption and input impedance must be observed.
- 3** Actuators may also be powered by DC 24 V.
- 5** Only connect common to negative (-) leg of control circuits.
- 7** A 500 Ω resistor (ZG-R01) converts the 4...20 mA control signal to 2...10 V.
- 18** Actuators with plenum cable do not have numbers; use color codes instead.
- Meets cULus requirements without the need of an electrical ground connection.
- Warning! Live electrical components!**  
 During installation, testing, servicing and troubleshooting of this product, it may be necessary to work with live electrical components. Have a qualified licensed electrician or other individual who has been properly trained in handling live electrical components perform these tasks. Failure to follow all electrical safety precautions when exposed to live electrical components could result in death or serious injury.

**Wiring diagrams**

AC 24 V Transformer

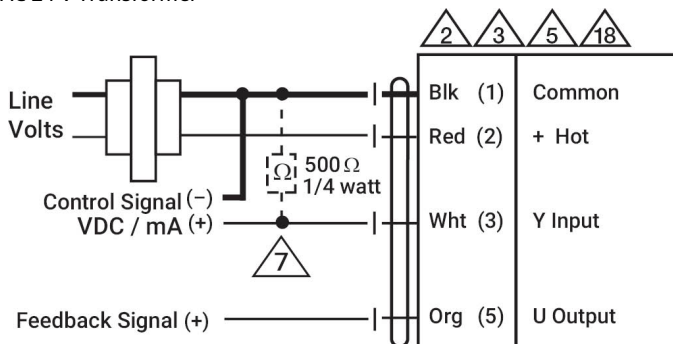

2 VDC	Close	
10 VDC	Open	