



5-year warranty

Technical data

<b>Functional data</b>	Mounting Position	90° to 180°
	<hr/>	
<b>Safety data</b>	Ambient temperature	-22...122°F [-30...50°C]
	Storage temperature	-40...176°F [-40...80°C]
<b>Materials</b>	Housing material	galvanized steel
	Stem	steel
	Frame, plate, base	galvanized steel
	Bearing	GF Delrin
<b>Suitable actuators</b>	Non-Spring	AMB(X) GMB(X) NMB(X)
	Electronic fail-safe	NKQB(X)

\* ZG-121 adapter must be used with EF. \*\* GM/GK not for use with 1/2" shafts. \*\*\* K6-1 clamp must be used with LF. For close-off pressure reference Select Pro or Retrofit Technical Documentation.  
For close-off pressure reference Select Pro or retrofit technical documentation.

Product features

- Default/Configuration** The ZG-JSL linkage can also be configured by moving the anti-rotation plate 90° for space-saving applications. See mounting configurations below. The ZG-JSLA will have a factory mounted actuator on the linkage in the vertical position only.
- Application** The ZG-JSL jackshaft linkage is designed to easily attach to any part of a jackshaft and allow easy installation of select Belimo actuators. The unique open ended design and clamp insert allows the ZG-JSL to be used with any jackshaft from 1/2" to 3/4" in diameter. Removal of the insert will allow the linkage to attach to a maximum shaft diameter of 1.05". Changing the antirotation plate will allow various actuators to be mounted.
- Operation** The 3/4" diameter built-in steel shaft allows direct coupling to the Belimo series actuators in the chart below. There is a torque reduction when using the ZG-JSL linkage. Verify application requirements before use.

Flow/Mounting details

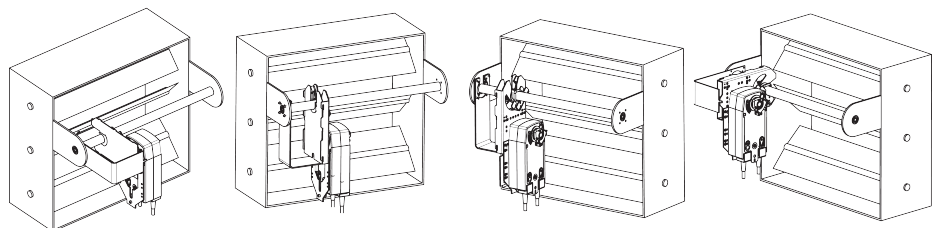

Dimensions

Dimensional drawings

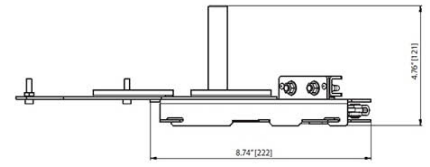
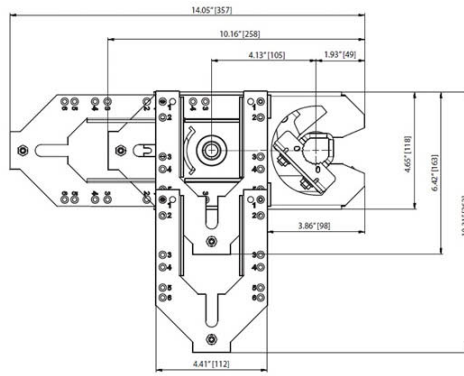



5-year warranty



**MFT**

Technical data

<b>Electrical data</b>	Nominal voltage	AC/DC 24 V
	Nominal voltage frequency	50/60 Hz
	Power consumption in operation	3.5 W
	Power consumption in rest position	1.3 W
	Transformer sizing	6 VA (class 2 power source)
	Electrical Connection	18 GA plenum cable with 1/2" conduit connector, degree of protection NEMA 2 / IP54, 3 ft [1 m] 10 ft [3 m] and 16ft [5 m]
	Overload Protection	electronic throughout 0...95° rotation
<b>Functional data</b>	Torque motor	90 in-lb [10 Nm]
	Operating range Y	0...135 $\Omega$
	Operating range Y note	Honeywell Electronic Series 90, input 0...135 $\Omega$
	Position feedback U	2...10 V
	Position feedback U note	Max. 0.5 mA
	Position feedback U variable	VDC variable
	Direction of motion motor	selectable with switch 0/1
	Manual override	external push button
	Angle of rotation	Max. 95°, adjustable with mechanical stop
	Angle of rotation note	adjustable with mechanical stop
	Running Time (Motor)	default 150 s, variable 45...170 s
	Running time motor variable	45...170 s
	Noise level, motor	45 dB(A)
	Shaft Diameter	1/2...1.05" round, centers on 1/2" and 3/4" with insert, 1.05" without insert
Position indication	Mechanically, 30...65 mm stroke	
<b>Safety data</b>	Degree of protection IEC/EN	IP54
	Degree of protection NEMA/UL	NEMA 2 UL Enclosure Type 2
	Agency Listing	cULus acc. to UL60730-1A/-2-14, CAN/CSA E60730-1:02, CE acc. to 2014/30/EU and 2014/35/EU
	Quality Standard	ISO 9001
	Ambient temperature	-22...122°F [-30...50°C]
	Storage temperature	-40...176°F [-40...80°C]
	Ambient humidity	max. 95% r.H., non-condensing
	Servicing	maintenance-free
<b>Weight</b>	Weight	1.2 lb [0.55 kg]
<b>Materials</b>	Housing material	UL94-5VA

**Product features**

- Application** For proportional modulation of dampers in HVAC systems. Actuator sizing should be done in accordance with the damper manufacturer's specifications.
- The actuator is mounted directly to a damper shaft up to 1.05" in diameter by means of its universal clamp. A crank arm and several mounting brackets are available for applications where the actuator cannot be direct coupled to the damper shaft.
- The default parameters for 0 to 135Ω input applications of the ...MFT95 actuator are assigned during manufacturing. If necessary, custom versions of the actuators can be ordered. The parameters can be changed by two means: pre-set and custom configurations from Belimo or on-site configurations using the Belimo PC-Tool software.
- Operation** The actuator is not provided with and does not require any limit switches, but is electronically protected against overload. The anti-rotation strap supplied with the actuator will prevent lateral movement.
- The actuator provides 95° of rotation and a visual indicator indicates position of the actuator. When reaching the damper or actuator end position, the actuator automatically stops. The gears can be manually disengaged with a button on the actuator cover.
- The actuators use a brushless DC motor, which is controlled by an Application Specific Integrated Circuit (ASIC). The ASIC monitors and controls the actuator's rotation and provides a digital rotation sensing (DRS) function to prevent damage to the actuator in a stall condition. Power consumption is reduced in holding mode.
- Add-on auxiliary switches or feedback potentiometers are easily fastened directly onto the actuator body for signaling and switching functions.
- For low ambient temperatures, the optional supplemental (-H) Heater add-on is available.
- Typical specification** Proportional control damper actuators shall be electronic type, with integrated linear stroking arm. Actuators must provide proportional damper control in response to a 2 to 10 VDC or, with the addition of a 500Ω resistor, a 4 to 20 mA control input from an electronic controller or positioner. Actuators shall have brushless DC motor technology and be protected from overload at all angles of rotation. Actuators shall have reversing switch and manual override on the cover. Run time shall be constant and independent of torque. A 2 to 10 VDC feedback signal shall be provided for position indication. Actuators shall be cULus listed, have a 5-year warranty, and be manufactured under ISO 9001 International Quality Control Standards. Actuators shall be as manufactured by Belimo.

**Accessories**

Electrical accessories	Description	Type
	Battery backup system, for non-spring return models	NSV24 US
	Feedback potentiometer 10 kΩ add-on, grey	P10000A GR
	Feedback potentiometer 1 kΩ add-on, grey	P1000A GR
	Feedback potentiometer 140 Ω add-on, grey	P140A GR
	Feedback potentiometer 2.8 kΩ add-on, grey	P2800A GR
	Feedback potentiometer 5 kΩ add-on, grey	P5000A GR
	Feedback potentiometer 500 Ω add-on, grey	P500A GR
	Auxiliary switch 1 x SPDT add-on	S1A
	Auxiliary switch 2 x SPDT add-on	S2A
	Transformer, AC 120 V to AC 24 V, 40 VA	ZG-X40
Mechanical accessories	Description	Type
	Shaft extension 240 mm Ø20 mm for damper shaft Ø 8...22.7 mm	AV8-25
	Shaft clamp reversible, clamping range Ø8...20 mm	K-NA
	Wrench 8 mm and 10 mm	TOOL-06
	17" Mounting Bracket for AF,NF,GM,AM,SM	ZG-100
	Mounting Bracket: AF,NF,LF,GM,AM,NM,SM	ZG-101
	Mounting Bracket: GM,AM,SM	ZG-103
	Mounting Bracket: GM,AM,SM	ZG-104
	Mounting kit for linkage operation for flat installation	ZG-NMA
	Shaft extension for 1/2" diameter shafts (3.8" L).	ZG-NMSA-1
	Weather shield 13x8x6" [330x203x152 mm] (LxWxH)	ZS-100
	Weather shield 16x8-3/8x4" [406x213x102 mm] (LxWxH)	ZS-150

**Electrical installation**

- ▲1 Provide overload protection and disconnect as required.
- ▲3 Actuators may also be powered by 24 VDC.
- ▲22 Actuators and controller must have separate transformers.
- ▲23 Consult controller instruction data for more detailed information.
- ▲24 Resistor value depends on the type of controller and the number of actuators. No resistor is used for one actuator. Honeywell® resistor kits may also be used.
- ▲25 To reverse control rotation, use the reversing switch.
- ▲46 Actuators may be controlled in parallel. Current draw and input impedance must be observed.

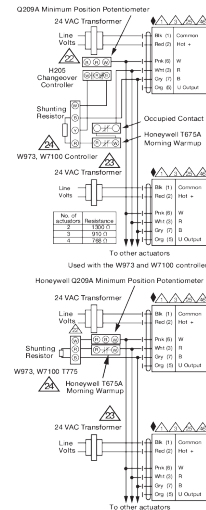
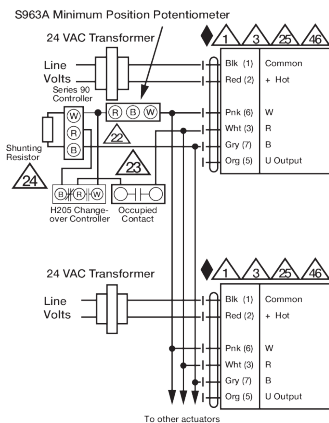
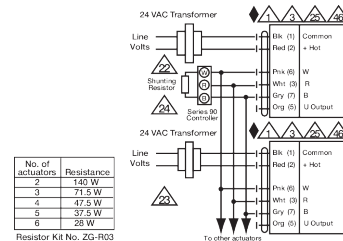
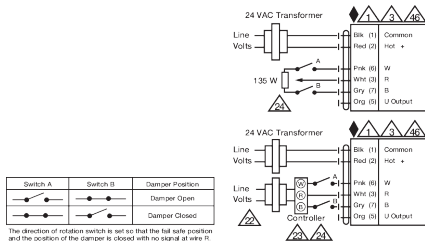
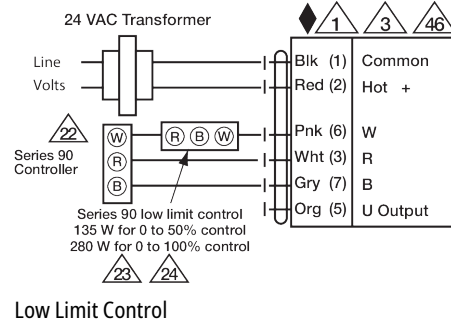
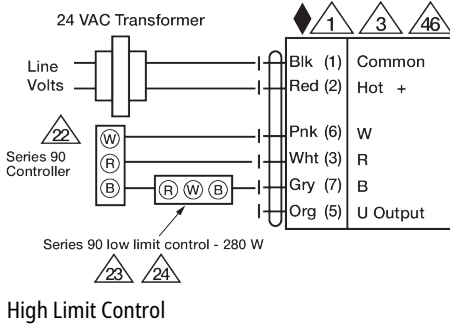

**Dimensions**

Dimensional drawings

∅ 1/2" to 1.05" [12.7 to 26.67]

□ 2/5" to 1.05" [10 to 26.67]

