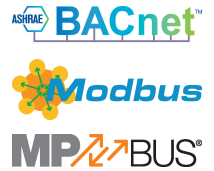
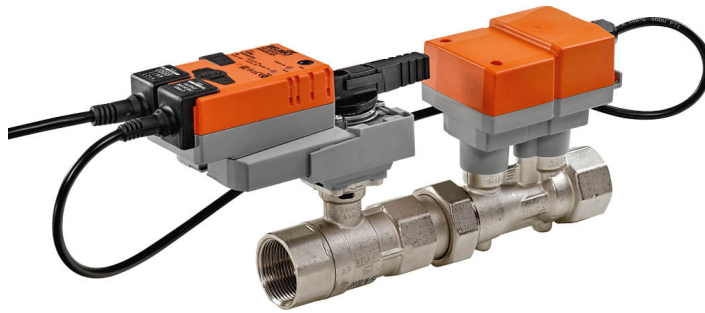

Characterised control valve with sensor-operated flow control, 2-way, Internal thread, PN 25 (EPIV)

- Nominal voltage AC/DC 24 V
- Control modulating, communicative, hybrid
- For closed cold and warm water systems
- For modulating control of air-handling and heating systems on the water side
- Communication via BACnet MS/TP, Modbus RTU, Belimo-MP-Bus or conventional control
- Conversion of active sensor signals and switching contacts

Type Overview

Type	DN	Rp ["]	V'nom [l/s]	V'nom [l/min]	V'nom [m³/h]	kvs theor. [m³/h]	PN
EP015R+MOD	15	1/2	0.35	21	1.26	2.9	25
EP020R+MOD	20	3/4	0.65	39	2.34	4.9	25
EP025R+MOD	25	1	1.15	69	4.14	8.6	25
EP032R+MOD	32	1 1/4	1.8	108	6.48	14.2	25
EP040R+MOD	40	1 1/2	2.5	150	9	21.3	25
EP050R+MOD	50	2	4.8	288	17.28	32.0	25

kvs theor.: Theoretical kvs value for pressure drop calculation

Technical data

Products no longer available

Electrical data	Nominal voltage	AC/DC 24 V
	Nominal voltage frequency	50/60 Hz
	Nominal voltage range	AC 19.2...28.8 V / DC 21.6...28.8 V
	Power consumption in operation	3.5 W (DN 15, 20, 25) 4.5 W (DN 32, 40, 50)
	Power consumption in rest position	1.3 W (DN 15, 20, 25) 1.4 W (DN 32, 40, 50)
	Power consumption for wire sizing	6 VA (DN 15, 20, 25) 7 VA (DN 32, 40, 50)
	Connection supply / control	Cable 1 m, 6 x 0.75 mm ²
Data bus communication	Communicative control	BACnet MS/TP Modbus RTU (default setting) MP-Bus
	Number of nodes	BACnet / Modbus see interface description MP-Bus max. 8
Functional data	Operating range Y	2...10 V
	Operating range Y variable	0.5...10 V
	Position feedback U	2...10 V
	Position feedback U note	Max. 1 mA
	Position feedback U variable	Start point 0.5...8 V End point 2...10 V
	Sound power level Motor	45 dB(A)
	Adjustable flow rate V'max	30...100% of V'nom
	Control accuracy	±5% (of 25...100% V'nom) @ 20°C / Glycol 0% vol.
	Control accuracy note	±10% (of 25...100% V'nom) @ -10...120°C / Glycol 0...50% vol.
	Min. controllable flow	1% of V'nom
	Fluid	Cold and warm water, water with glycol up to max. 50% vol.
Fluid temperature	-10...120°C [14...248°F]	

Functional data	Fluid temperature note	At a fluid temperature of -10...2°C, a spindle heater or a valve neck extension is recommended.
	Close-off pressure Δp_s	1400 kPa
	Differential pressure Δp_{max}	350 kPa
	Differential pressure note	200 kPa for low-noise operation
	Flow characteristic	equal percentage, optimised in the opening range (switchable to linear)
	Leakage rate	air-bubble tight, leakage rate A (EN 12266-1)
	Pipe connection	Internal thread according to ISO 7-1
	Installation position	upright to horizontal (in relation to the stem)
	Servicing	maintenance-free
	Manual override	with push-button, can be locked
Flow measurement	Measuring principle	Ultrasonic volumetric flow measurement
	Measuring accuracy flow	$\pm 2\%$ (of 25...100% V'nom) @ 20°C / glycol 0% vol.
	Measuring accuracy flow note	$\pm 6\%$ (of 25...100% V'nom) @ -10...120°C / glycol 0...50% vol.
	Min. flow measurement	0.5% of V'nom
Safety data	Protection class IEC/EN	III, Safety Extra-Low Voltage (SELV)
	Degree of protection IEC/EN	IP54
	Pressure equipment directive	CE according to 2014/68/EU
	EMC	CE according to 2014/30/EU
	Mode of operation	Type 1
	Rated impulse voltage supply / control	0.8 kV
	Pollution degree	3
	Ambient humidity	Max. 95% RH, non-condensing
	Ambient temperature	-30...50°C [-22...122°F]
	Storage temperature	-40...80°C [-40...176°F]
Materials	Valve body	Nickel-plated brass body
	Flow measuring pipe	Brass body nickel-plated
	Closing element	Stainless steel
	Spindle	Stainless steel
	Spindle seal	EPDM O-ring

Safety notes

- This device has been designed for use in stationary heating, ventilation and air-conditioning systems and must not be used outside the specified field of application, especially in aircraft or in any other airborne means of transport.
- Outdoor application: only possible in case that no (sea) water, snow, ice, insulation or aggressive gases interfere directly with the device and that it is ensured that the ambient conditions remain within the thresholds according to the data sheet at any time.
- Only authorised specialists may carry out installation. All applicable legal or institutional installation regulations must be complied during installation.
- The device contains electrical and electronic components and must not be disposed of as household refuse. All locally valid regulations and requirements must be observed.

Product features

Mode of operation The HVAC performance device is comprised of three components: characterised control valve (CCV), measuring pipe with flow sensor and the actuator itself. The adjusted maximum flow (V_{max}) is assigned to the maximum control signal (typically 100%). The HVAC performance device can be controlled via communicative signals. The fluid is detected by the sensor in the measuring pipe and is applied as the flow value. The measured value is balanced with the setpoint. The actuator corrects the deviation by changing the valve position. The angle of rotation α varies according to the differential pressure through the control element (see flow curves).

Flow rate curves

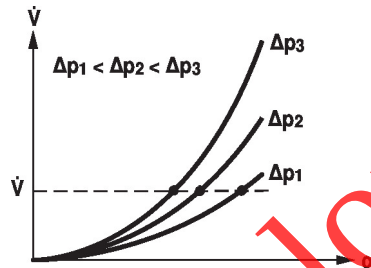

Transmission behaviour HE

Heat exchanger transmission behaviour
 Depending on the construction, temperature spread, fluid characteristics and hydronic circuit, the power Q is not proportional to the water volumetric flow V' (Curve 1). With the classical type of temperature control, an attempt is made to maintain the control signal Y proportional to the power Q (Curve 2). This is achieved by means of an equal-percentage flow characteristic (Curve 3).



Products no longer available

Control characteristics

The fluid velocity is measured in the measuring component (sensor electronics) and converted into a flow rate signal.

The control signal Y corresponds to the power requirement Q at the exchanger. The flow is regulated in the EPiV. The control signal Y is converted into an equal-percentage characteristic curve and provided with the V'max value as the new reference variable w. The momentary control deviation forms the control signal Y1 for the actuator.

The specially configured control parameters in conjunction with the precise flow rate sensor ensure a stable control quality. They are however not suitable for rapid control processes, i.e. for domestic water control.

The measured flow rate is in l/min as an absolute flow output.

The absolute position sets the valve opening angle in %.

The relative position always refers to the nominal flow V'nom, i.e. if V'max is configured with 50% of V'nom, then the relative position at a setpoint of 100% is equal to 50% of V'nom.

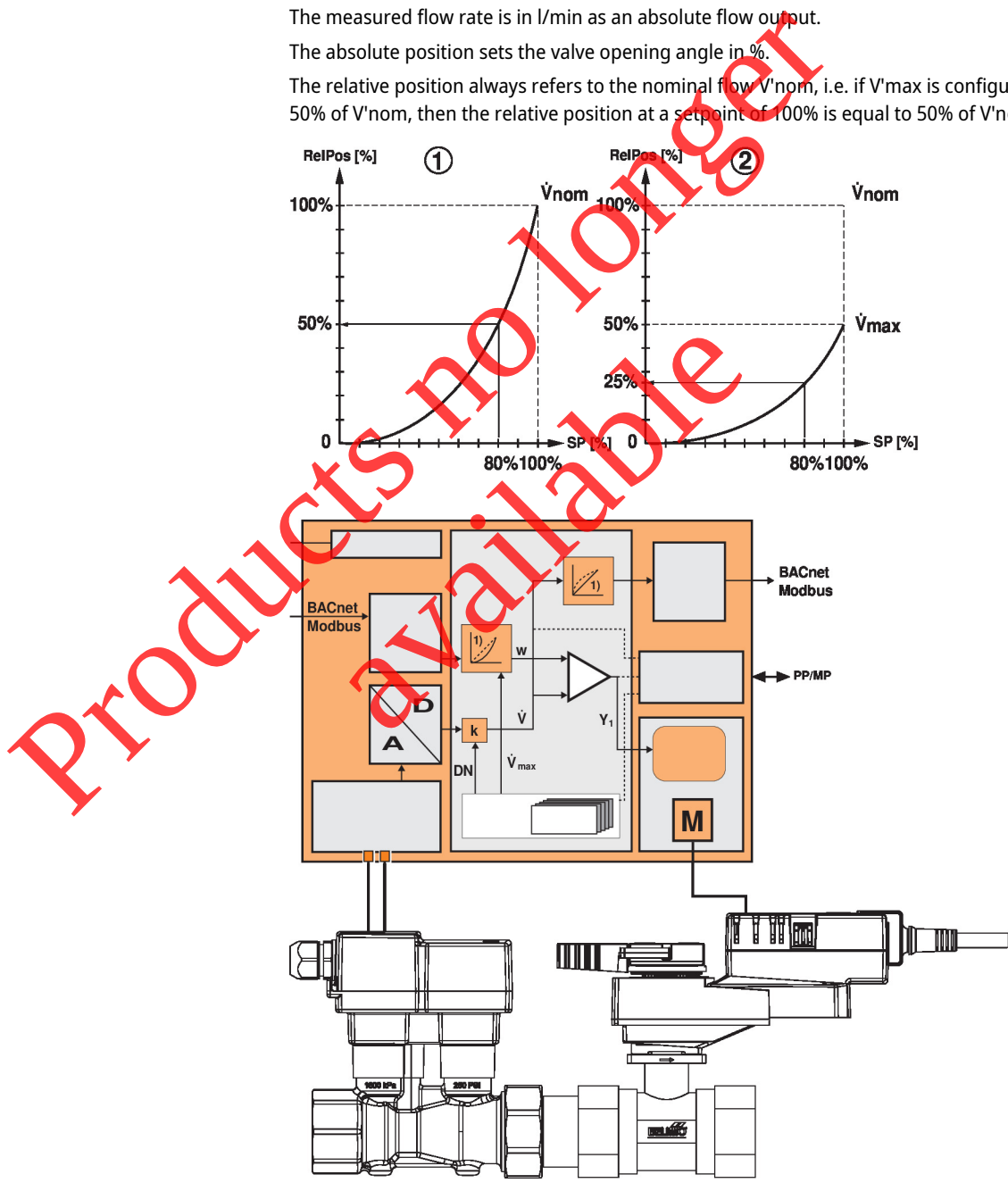
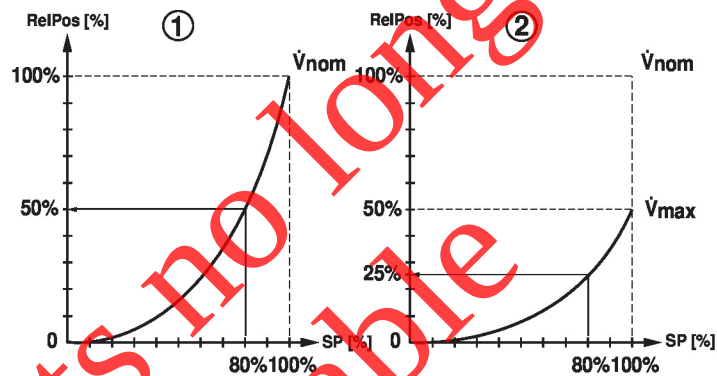

Definition Flow control

\dot{V}'_{nom} is the maximum possible flow.

\dot{V}'_{max} is the maximum flow rate which has been set with the highest control signal. \dot{V}'_{max} can be set between 30% and 100% of \dot{V}'_{nom} .

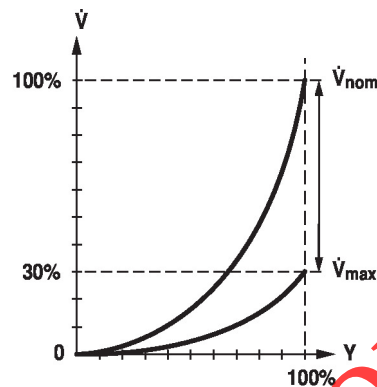
Creep flow suppression

Given the very low flow speed in the opening point, this can no longer be measured by the sensor within the required tolerance. This range is overridden electronically.

Opening valve

The valve remains closed until the flow required by the control signal DDC corresponds to 1% of \dot{V}'_{nom} . The control along the flow characteristic is active after this value has been exceeded.

Closing valve

The control along the flow characteristic is active up to the required flow rate of 1% of \dot{V}'_{nom} . Once the level falls below this value, the flow rate is maintained at 1% of \dot{V}'_{nom} . If the level falls below the flow rate of 0.5% of \dot{V}'_{nom} required by the control signal DDC, then the valve will close.

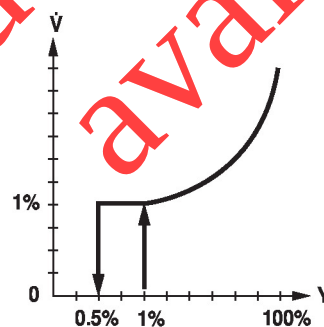
Converter for sensors

Connection option for a sensor (active or with switching contact). In this way, the analogue sensor signal can be easily digitised and transferred to the bus systems BACnet, Modbus or MP-Bus.

Configurable actuators

The factory settings cover the most common applications. Single parameters can be modified with the Belimo Service Tools MFT-P or ZTH EU.

The communication parameters of the bus systems (address, baud rate etc.) are set with the ZTH EU. Pressing the "Address" button on the actuator while connecting the supply voltage, resets the communication parameters to the factory setting.

Quick addressing: The BACnet and Modbus address can alternatively be set using the buttons on the actuator and selecting 1...16. The value selected is added to the «Basic address» parameter and results in the effective BACnet and Modbus address.

Hydronic balancing

With the Belimo tools, the maximum flow rate (equivalent to 100% requirement) can be adjusted on-site, simply and reliably, in a few steps. If the device is integrated in the management system, then the balancing can be handled directly by the management system.

Combination analogue - communicative (hybrid mode)

With conventional control by means of an analogue control signal, BACnet or Modbus can be used for the communicative position feedback

Manual override Manual override with push-button possible (the gear train is disengaged for as long as the button is pressed or remains locked).

High functional safety The actuator is overload protected, requires no limit switches and automatically stops when the end stop is reached.

Accessories

Mechanical accessories	Description	Type
	Valve neck extension for ball valve DN 15...50	ZR-EXT-01
	Pipe connector for ball valve DN 15	ZR2315
	Pipe connector for ball valve DN 20	ZR2320
	Pipe connector for ball valve DN 25	ZR2325
	Pipe connector for ball valve DN 32	ZR2332
	Pipe connector for ball valve DN 40	ZR2340
	Pipe connector for ball valve DN 50	ZR2350
Tools	Description	Type
	Service Tool, with ZIP-USB function, for parametrisable and communicative Belimo actuators, VAV controller and HVAC performance devices	ZTH EU
	Belimo PC-Tool, Software for adjustments and diagnostics	MFT-P
	Adapter for Service-Tool ZTH	MFT-C
	Connection cable 5 m, A: RJ11 6/4 ZTH EU, B: 6-pin for connection to service socket	ZK1-GEN
	Connection cable 5 m, A: RJ11 6/4 ZTH EU, B: free wire end for connection to MP/PP terminal	ZK2-GEN

Electrical installation

Supply from isolating transformer.

The wiring of the line for BACnet MS/TP / Modbus RTU is to be carried out in accordance with applicable RS-485 regulations.

Modbus / BACnet: Supply and communication are not galvanically isolated. Connect earth signal of the devices with one another.

BACnet MS/TP / Modbus RTU

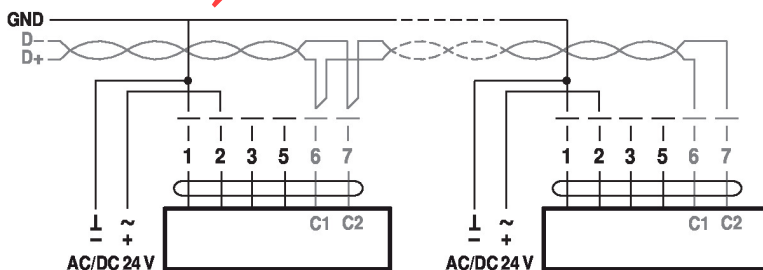

Cable colours:

- 1= black
 - 2 = red
 - 3 = white
 - 5 = orange
 - 6 = pink
 - 7 = grey
- BACnet / Modbus signal assignment:
 C1 = D- = A
 C2 = D+ = B

Connection with active sensor, e.g. 0...10 V @ 0...50°C

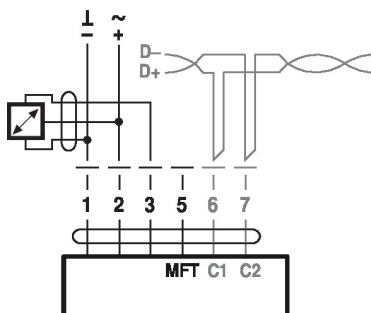

Possible voltage range:
 0...32 V (resolution 30 mV)

Connection with switching contact, e.g. Δp monitor

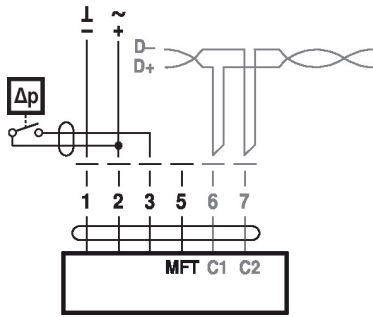

Requirements for switching contact:

The switching contact must be able to accurately switch a current of 16 mA @ 24 V.

Modbus RTU / BACnet MS/TP with analogue setpoint (hybrid mode)

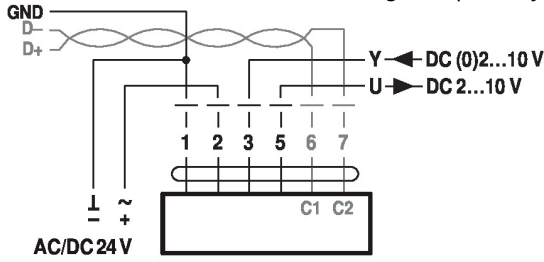

Operation on the MP-Bus

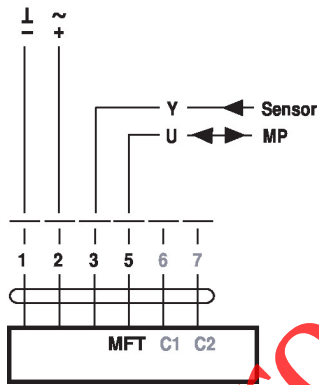

Products no longer available

Operating controls and indicators

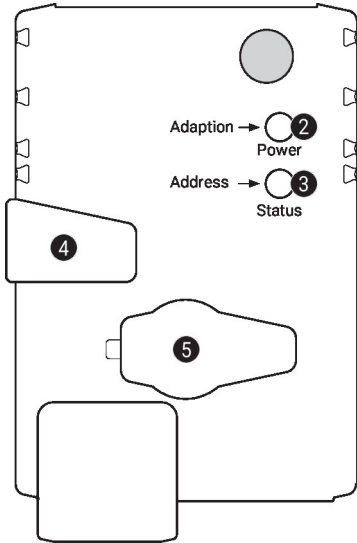

2 Push-button and LED display green

- Off: No power supply or malfunction
- On: In operation
- Flashing: In address mode: Pulses according to set address (1...16)
When starting: Reset to factory setting (Communication)
- Press: In standard mode: Triggers angle of rotation adaptation button:
In address mode: Confirmation of set address (1...16)

3 Push-button and LED display yellow

- Off: Standard mode
- On: Adaptation or synchronisation process active or actuator in address mode (LED display green flashing)
- Flickering: BACnet / Modbus communication active
- Press button: In operation (>3 s): Switch address mode on and off
In address mode: Address setting by pressing several times
When starting (>5 s): Reset to factory setting (Communication)

4 Manual override button

- Press button: Gear train disengages, motor stops, manual override possible
- Release button: Gear train engages, standard mode

5 Service plug

For connecting parametrisation and service tools

Check power supply connection

- 2** Off and **3** On Possible wiring error in power supply

Installation notes

Recommended installation positions

The ball valve can be installed upright to horizontal. The ball valve may not be installed in a hanging position, i.e. with the spindle pointing downwards.

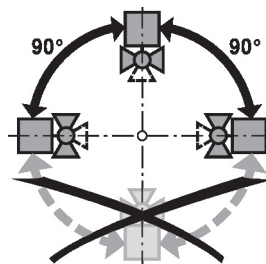

Installation position in return

Installation in the return is recommended.

Water quality requirements

The water quality requirements specified in VDI 2035 must be adhered to. Belimo valves are regulating devices. For the valves to function correctly in the long term, they must be kept free from particle debris (e.g. welding beads during installation work). The installation of a suitable strainer is recommended.

Servicing Ball valves, rotary actuators and sensors are maintenance-free.

Before any service work on the control element is carried out, it is essential to isolate the rotary actuator from the power supply (by unplugging the electrical cable if necessary). Any pumps in the part of the piping system concerned must also be switched off and the appropriate slide valves closed (allow all components to cool down first if necessary and always reduce the system pressure to ambient pressure level).

The system must not be returned to service until the ball valve and the rotary actuator have been correctly reassembled in accordance with the instructions and the pipeline has been refilled by professionally trained personnel.

Flow direction The direction of flow, specified by an arrow on the housing, is to be complied with, since otherwise the flow rate will be measured incorrectly.

Inlet section In order to achieve the specified measuring accuracy, a flow-calming section or inflow section in the direction of the flow is to be provided upstream from the flow sensor. Its dimensions should be at least 5x DN.

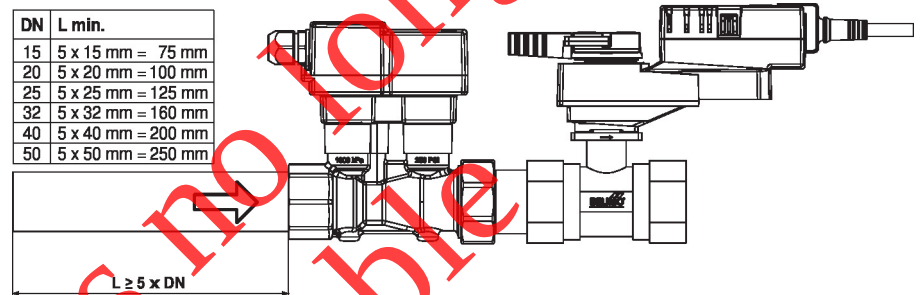

Split installation The valve-actuator combination may be mounted separately from the flow sensor. The direction of flow must be observed.

General notes

Minimum differential pressure (pressure drop)

The minimum required differential pressure (pressure drop through the valve) for achieving the desired volumetric flow \dot{V}_{\max} can be calculated with the aid of the theoretical kvs value (see type overview) and the below-mentioned formula. The calculated value is dependent on the required maximum volumetric flow \dot{V}_{\max} . Higher differential pressures are compensated for automatically by the valve.

Formula

$$\Delta p_{\min} = 100 \times \left(\frac{\dot{V}_{\max}}{k_{vs \text{ theor.}}} \right)^2$$

$\Delta p_{\min}: \text{kPa}$
 $\dot{V}_{\max}: \text{m}^3/\text{h}$
 $k_{vs \text{ theor.}}: \text{m}^3/\text{h}$

Example (DN 25 with the desired maximum flow rate = 50% \dot{V}_{nom})

EP025R+MOD

$k_{vs \text{ theor.}} = 8.6 \text{ m}^3/\text{h}$

$\dot{V}_{\text{nom}} = 69 \text{ l/min}$

$50\% * 69 \text{ l/min} = 34.5 \text{ l/min} = 2.07 \text{ m}^3/\text{h}$

$$\Delta p_{\min} = 100 \times \left(\frac{\dot{V}_{\max}}{k_{vs \text{ theor.}}} \right)^2 = 100 \times \left(\frac{2.07 \text{ m}^3/\text{h}}{8.6 \text{ m}^3/\text{h}} \right)^2 = 6 \text{ kPa}$$

Behaviour in case of sensor failure

In case of a flow sensor error, the EPIV will switch from flow control to position control. Once the error disappears, the EPIV will switch back to the normal control setting.

Service

- Quick addressing**
1. Press the "Address" button until the green "Power" LED is no longer illuminated. LED flashes in accordance with the previously set address.
 2. Set the address by pressing the "Address" button the corresponding number of times (1...16).
 3. The green LED flashes in accordance with the address that has been entered (...16). If the address is not correct, then this can be reset in accordance with Step 2.
 4. Confirm the address setting by pressing the green "Adaptation" button.
- If no confirmation occurs for 60 seconds, then the address procedure is ended. Any address change that has already been started will be discarded.
- The resulting BACnet MS/TP and Modbus RTU address is made up of the set basic address plus the short address (e.g. 100+7=107).

Tools connection The actuator can be parametrised by ZTH EU via the service socket. For an extended parametrisation the PC tool can be connected.

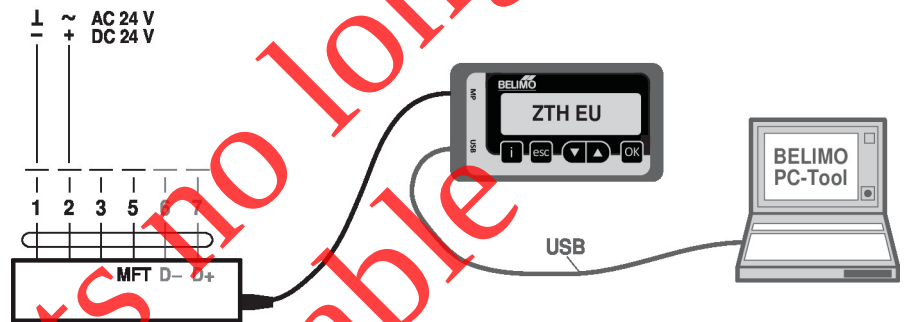

Dimensions

Dimensional drawings

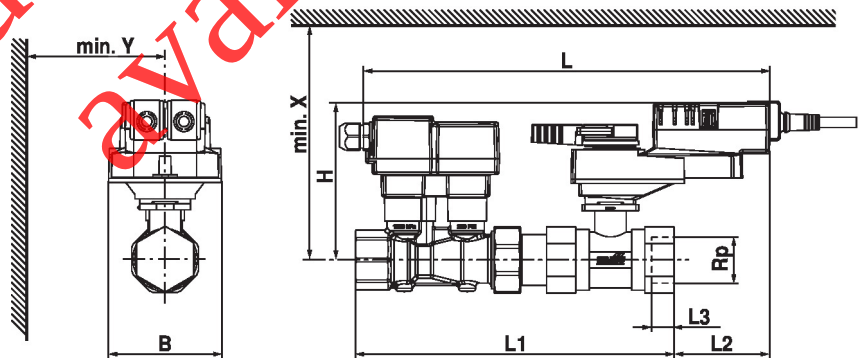

Type	DN	Rp ["]	L [mm]	L1 [mm]	L2 [mm]	L3 [mm]	B [mm]	H [mm]	X [mm]	Y [mm]	kg
EP015R+MOD	15	1/2	275	192	81	13	75	125	195	77	1.5
EP020R+MOD	20	3/4	291	211	75	14	75	125	195	77	1.8
EP025R+MOD	25	1	295	230	71	16	75	127	197	77	2.1
EP032R+MOD	32	1 1/4	323	255	68	19	85	131	201	77	2.8
EP040R+MOD	40	1 1/2	325	267	65	19	85	141	211	77	3.3
EP050R+MOD	50	2	343	288	69	22	95	142	212	77	4.5

Further documentation

- Tool connections
- BACnet Interface description
- Modbus Interface description
- Overview MP Cooperation Partners
- MP Glossary
- Introduction to MP-Bus Technology
- General notes for project planning