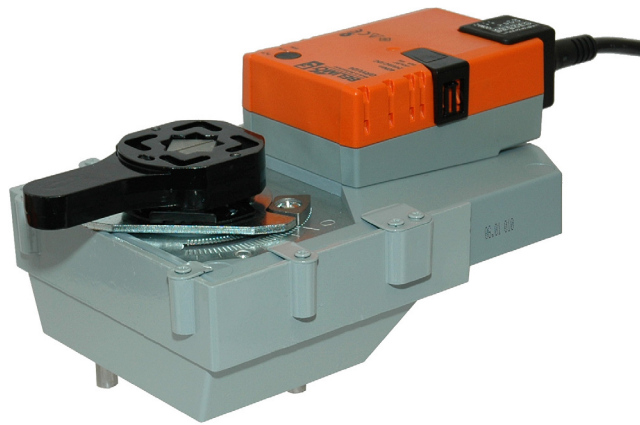

**Rotary actuator for LONWORKS®
for butterfly valves**

- Torque 40 Nm
- Nominal voltage AC/DC 24 V
- Communications via LONWORKS® (FTT-10A)
- Conversion of sensor signals
- Integrated temperature controller

Technical data
Electrical data

Nominal voltage	AC 24 V, 50/60 Hz / DC 24 V
Nominal voltage range	AC 19.2 ... 28.8 V / DC 21.6 ... 28.8 V
Power consumption	Operation 4.5 W @ nominal torque
	At rest 1.5 W
	For wire sizing 7 VA
Connection	Cable 1 m, 6 x 0.75 mm ²

Data for LONWORKS®

Certified	in accordance with LONMARK® 3.3
Processor	Neuron 3150
Transceiver	FTT-10A, compatible with LPT-10
Functional Profile as per LONMARK®	Damper actuator object #8110 Open Loop Sensor Object #1 Thermostat Object #8000
LNS plug-in for actuator / sensor / controller	Can be run with any LNS based Integration tool (min. for LNS 3.x)
Service button and status LED	in accordance with guidelines LONMARK®
Conductors, cables	Conductor lengths, cable specifications and topology of the LONWORKS® network in accordance with the ECHELON® guidelines

Functional data	Factory settings	Variable	Setting
Torque (nominal torque)	Min. 40 Nm @ nominal voltage	25%, 50%, 75% reduced
Uni-rotation	±5%		
Running time	90 s / 90° \triangleleft	90 ... 290 s
Automatic adjustment of running time, operating range and measuring signal U to match the mechanical angle of rotation	Manual triggering of the adaption by pressing the «Adaption» button or with the PC-Tool	Automatic adaption whenever the supply voltage is switched on, or manual triggering
Angle of rotation limiting	MAX (maximum position) = 100% MIN (minimum position) = 0% ZS (intermediate position, only AC) = 50%	MAX = (MIN + 30° \triangleleft) ... 100% MIN = 0% ... (MAX - 30° \triangleleft) ZS = MIN ... MAX
Sound intensity	Max. 45 dB (A)	With a running time of 75 s = 50 dB (A) 290 s < 40 dB (A)	
Position indication	Mechanical, pluggable		

Safety

Protection class	III Safety low voltage
Degree of protection	IP54 in any mounting position
EMC	CE according to 2004/108/EC
Mode of operation	Type 1 (acc. to EN 60730-1)
Rated impulse voltage	0.8 kV (acc. to EN 60730-1)
Control pollution degree	3 (acc. to EN 60730-1)
Ambient temperature	+0 ... +50 °C
Medium temperature	-20 ... +100 °C in the butterfly valve
Non-operating temperature	-40 ... +80 °C
Ambient humidity range	95% r.h., non-condensating (EN 60730-1)
Maintenance	Maintenance-free

Technical data (continued)

Dimensions / Weight

Dimensions	See «Dimensions» on page 3
Weight	Approx. 2500 g



Safety notes



- The rotary actuator was designed for use in stationary, heating, ventilation and air conditioning systems and may not be used outside of the specific field of application, especially in aircraft or in any other airborne means of transport.
- They may only be installed by suitably trained personnel.
Any legal regulations or regulations issued by authorities must be observed during assembly.
- The switch for changing the direction of rotation may only be operated by authorised personnel. The direction of rotation must not be reversed in a frost protection circuit.
- The device may only be opened at the manufacturer's site. It does not contain any parts that can be replaced or repaired by the user.
- The cable must not be removed from the device.
- The device contains electrical and electronic components and is not allowed to be disposed of as household refuse. All locally valid regulations and requirements must be observed.

Product features

Mode of operation	The actuator is equipped with an integrated interface for LONWORKS®. The actuator can be connected and controlled directly with LONWORKS® via transceiver FTT-10A.
Converter for sensors	Connection option for a sensor (passive or active sensor or switching contact). In this way, the analogue sensor signal can be easily digitised and transferred to LONWORKS®.
Integrated temperature controller	The actuator has an integrated temperature controller (Thermostat Object LONMARK® #8060). This makes it easy to implement individual room control solutions. The temperature controller can be set using the LNS Plug-In available from Belimo.
Parameterisable actuators	The factory settings cover the most common applications. As desired, individual parameters can be adapted for specific systems or servicing with an MFT parameterisation device (e.g. PC-Tool MFT-P).
Simple direct mounting	Straightforward direct mounting on the ball valve with only one screw. The assembly tool is integrated in the plug-in position indication. The mounting position in relation to the ball valve can be selected in 90° steps.
Manual override	Manual control with pushbutton possible - temporary, permanently The gear is disengaged and the actuator decoupled for as long as the button is pressed / latched.
Adjustable angle of rotation	Adjustable angle of rotation with mechanical end stops.
High operational reliability	The actuator is overload-proof, requires no limit switches and automatically stops when the end stop is reached.
ISO 5211 - F05 Butterfly valve D6..	For BELIMO F05 butterfly valve D6 and other dampers with the following mechanical specifications: - Square stem head (14 mm) for form-fit attachment of the rotary actuator. - Hole circle (d = 50 mm) for assembly with the butterfly valve.
Home position	When the supply voltage is switched on for the first time, i.e. at commissioning or after pressing the "gear disengagement" switch, the actuator moves to the home position. Factory setting: Y2 (counter-clockwise rotation)

Rotary actuator	Rotary valve
 Y2	A - AB = 0%
 Y1	A - AB = 100%

The actuator then moves into the position defined by LONWORKS®.

Dimensions [mm]

Dimensional drawings

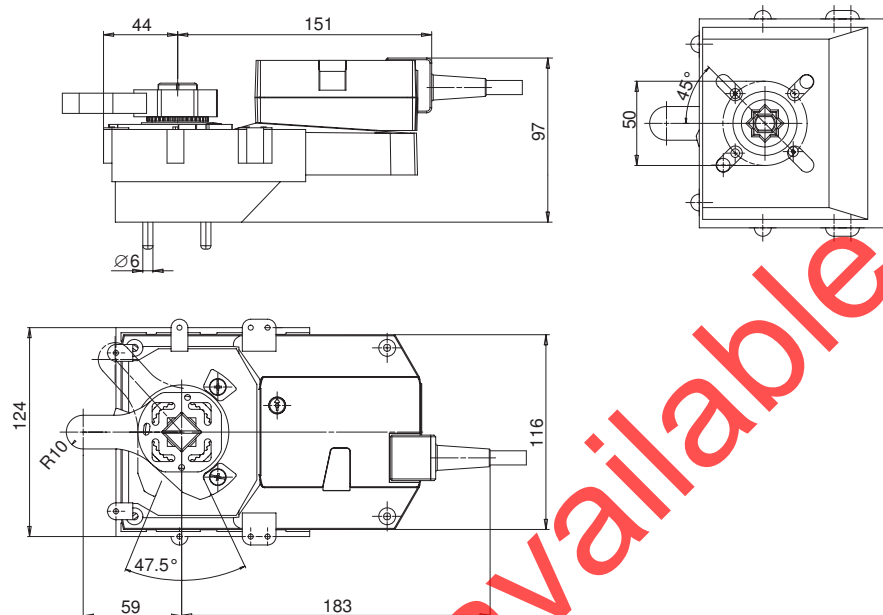

Further documentations

- Complete overview of actuators, water
- Data sheets for characterised control valves
- Installation instructions for actuators or ball valves, respectively
- Notes for project planning (hydraulic characteristic curves and circuits, installation regulations, commissioning, maintenance, etc.)

Functional Profile as per LONMARK®

The LON-capable rotary actuator is certified by LONMARK®. Die following actuator functions are made available via the LONWORKS® network as standardised network variables in accordance with LONMARK®: the Node Object #0, the Damper Actuator Object #8110, the Open Loop Sensor Object #1 and the Thermostat Object #8060.

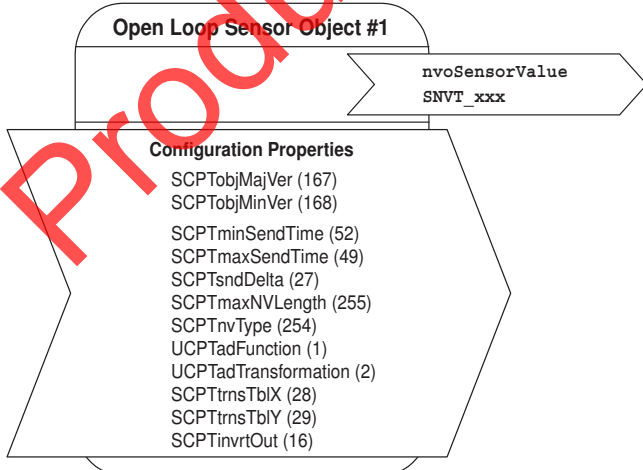
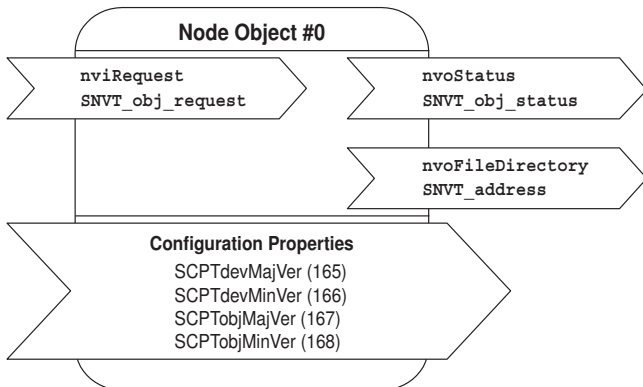

Node object #0

The node object contains the object status and object request functions.

- nviRequest** **SNVT_obj_request**
Input variable for requesting the status of a particular object in the node.
- nvoStatus** **SNVT_obj_status**
Output variable that outputs the current status of a particular object in the node.
- nvoFileDirectory** **SNVT_address**
Output variable that shows information in the address range of the Neuron chip.

Damper actuator object #8110

The actuator object is used to display the functions of the actuator on the page of the LONWORKS® network.

- nviRelStpt** **SNVT_lev_percent**
The nominal position is assigned to the actuator via this input variable. This variable is normally linked to the output variable of an HVAC controller.
- nviActuateState** **SNVT_switch**
A preset position is assigned to the actuator via this input variable. Note on priority: The variable which was most recently active, either nviActuatorState or nviRelStpt, has priority.
- nviManOvrld** **SNVT_hvac_overid**
This input variable can be used to manually override the actuator into a particular position.
- nvoActualValue** **SNVT_lev_percent**
This output variable shows the current actual position of the actuator and can be used for control circuit feedback or for displaying positions.
- nvoAbsAngle** **SNVT_angle_deg**
This output variable shows the current angle of rotation of the actuator and can be used to display the position or for service purposes.
- nvoAbsAirFlow** **SNVT_flow**
This output variable is inactive with this actuator and shows a constant value of 65535 (this variable is only active in conjunction with LON-capable VAV controllers).

Open Loop Sensor Object #1

One sensor can be connected to the actuator. A passive resistance sensor (e.g. Ni1000), an active sensor (output 0 ... 32 V) or a switch (On/Off) can be connected. In the case of the open loop sensor object, the measured sensor values are transferred to the LONWORKS® network.

- nvoSensorValue** **SNVT_xxx**
This output variable shows the current sensor value. Depending on the connected sensor, the output variable can be configured via the sensor plug-in and specifically adapted to the system.

The SNVT .. can be configured as:		
SNVT_temp_p	SNVT_lev_percent	SNVT_lux
SNVT_temp	SNVT_abs_humid	SNVT_press_p
SNVT_switch	SNVT_enthalpy	SNVT_smo_obscur
SNVT_flow	SNVT_ppm	SNVT_power
SNVT_flow_p	SNVT_rpm	SNVT_elec_kwh

Functional Profile as per LONMARK® (continued)

Individual room control solutions can be implemented with the thermostat object LONMARK® #8060. An LNS plug-in is available for configuring the controller parameters.

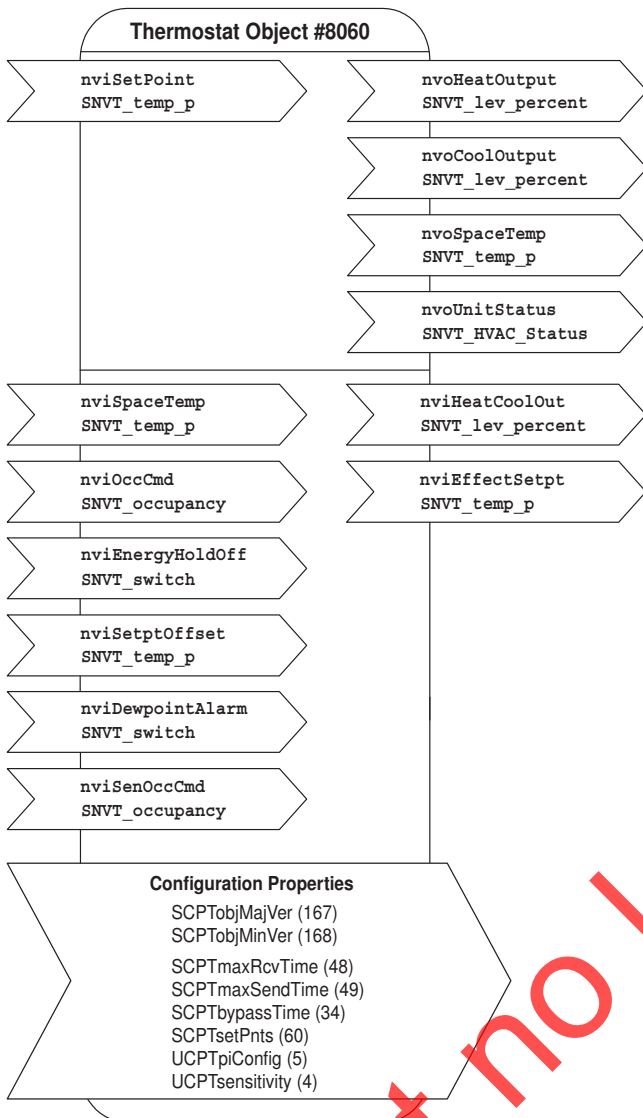

Note
A restart is necessary after accessing network variables for the purpose of rewriting them or after deleting links in order to initialise the variables.

Thermostat Object #8060

nviSetPoint **SNVT_temp_p**
Setpoint specification for the controller from the higher-level system or the room control unit. If this variable is not linked, then the local setpoints of the controller object apply (can be adjusted via plug-in). The setpoint specification from the higher-level system influences the setting on the controller as follows:

Example: Comfort setpoint for heating = 21 °C and Comfort setpoint for cooling = 23 °C. The median point between heating and cooling is thus 22 °C. Now, if the external setpoint (nviSetPoint) is 23 °C, then the heating setpoint will shift to 22 °C and the cooling set point to 24 °C. The setpoints for Pre-Comfort heating and cooling will also be shifted accordingly.

nviSpaceTemp **SNVT_temp_p**
Room temperature from external room sensor. It is imperative that this variable be linked; typically, it is linked with the variable of the sensor object.

nviOccCmd **SNVT_occupancy**
Occupancy specification from the command centre (for the function, see the table entitled «Functions Inputs Occupancy» page 5).

nviEnergyHoldOff **SNVT_switch**
In the case of active EnergyHoldOff, the controller will be set to the Building Protection setpoints.

nviSetPtOffset **SNVT_temp_p**
Shifting of the room control unit. If the nviSetPoint is linked, then this input has an influence on the variable value of nviSetPoint, i.e. it corrects it. Otherwise, the Comfort and Pre-Comfort setpoints for heating and cooling will be adjusted directly by the amount of the shift (compare example with nviSetPoint).

nviDewpointAlarm **SNVT_switch**
In the case of active DewpointAlarm, the controller will be set to the Building Protection setpoints. The cooling sequence is deactivated.

nviSenOccCmd **SNVT_occupancy**
Occupancy specification from the local occupancy switch (for the function, see the table entitled «Functions Inputs Occupancy» page 5).

nvoHeatOutput **SNVT_lev_percent**
Control signal for heating.

nvoCoolOutput **SNVT_lev_percent**
Control signal for cooling.

nvoSpaceTemp **SNVT_temp_p**
Displays the room temperature of the nviSpaceTemp. If nviSpaceTemp is not linked, then the variable will display the value 0x7FFF.

nvoUnitStatus **SNVT_HVAC_Status**
Displays the operating mode of the controller (in accordance with Functional Profile #8060).

nvoHeatCoolOut **SNVT_lev_percent**
Depicts the heating and cooling sequence for controlling the 6-way characterised control valves (see illustration, page 5). This outlet runs parallel to the nvoCoolOutput or the nvoHeatOutput, respectively.
Cooling = 33 ... 0%
Valve closed 33 ... 66%
Heating = 66 ... 100%

nvoEffectSetpt **SNVT_temp_p**
Shows the actual setpoint of the controller.

Functional Profile as per LONMARK®

Continued

Functions Inputs Occupancy

Note

The function nviOccCmd has a higher priority than the function nviSenOccCmd.

Occupancy specification from nviOccCmd command centre	Occupancy switch nviSenOccCmd	Room operating status	Comfort extension
OC_OCCUPIED	OC_OCCUPIED	Comfort	
	OC_UNOCCUPIED	Comfort	
	OC_NUL (default)	Comfort	
OC_STANDBY	OC_OCCUPIED	Bypass	Occupied time is extended by the amount of the bypass time (comfort time) (can be adjusted in the plug-in)
	OC_UNOCCUPIED	Pre-comfort	
	OC_NUL (default)	Pre-comfort	
OC_UNOCCUPIED	OC_OCCUPIED	Building protection	
	OC_UNOCCUPIED	Building protection	
	OC_NUL (default)	Building protection	
OC_NUL (default)	OC_OCCUPIED	Comfort	
	OC_UNOCCUPIED	Pre-comfort	
	OC_NUL (default)	Comfort	

Function nvoHeatCoolOut

Typical application

Heating / cooling with Belimo 6-way characterised control valve.

Note chilled ceiling application

In the case of active DewPointAlarm (nviDewPointAlarm), the controller will be set to the Building Protection setpoints. The cooling sequence is deactivated.

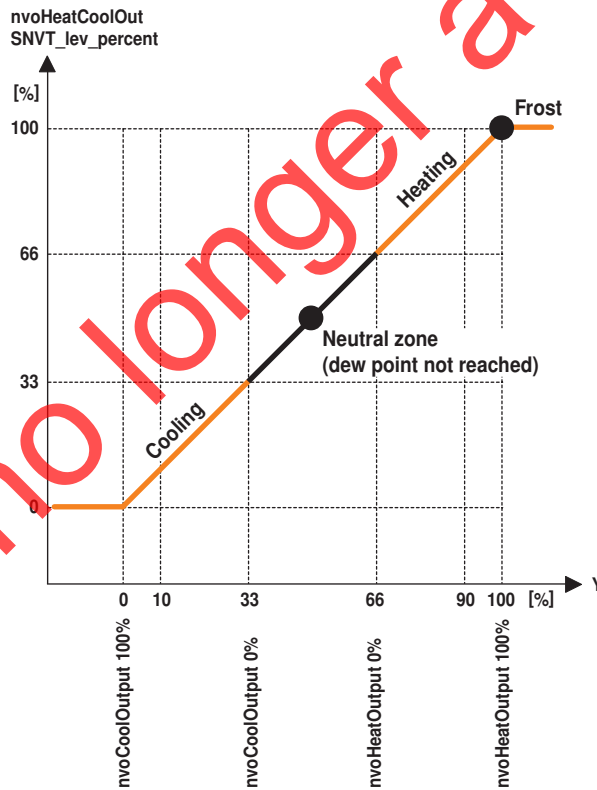

Notes

More detailed information on the functional profiles can be found on the website of LONMARK® (www.lonmark.org).

Electrical installation

Wiring diagrams

Note

Connect via safety isolation transformer.



Connection without sensor

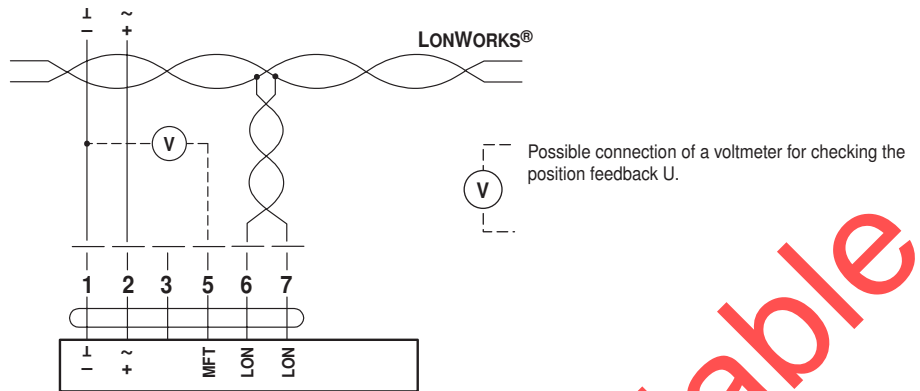

Connection with passive sensor, e.g. Pt1000, Ni1000, NTC

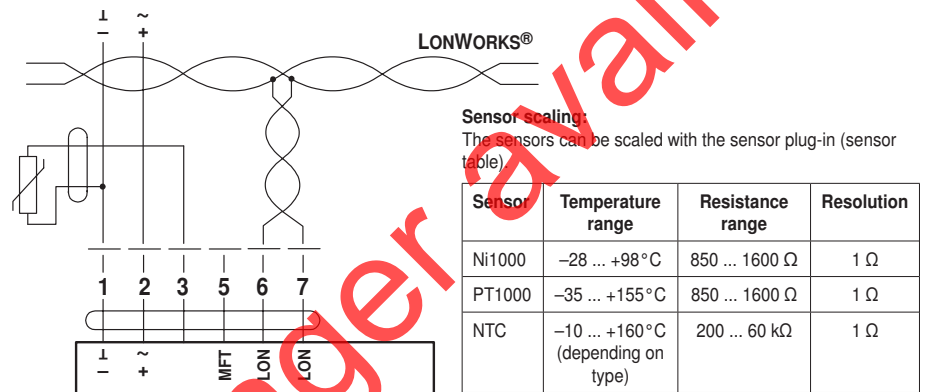

Connection with switching contact, e.g. Δp-monitor

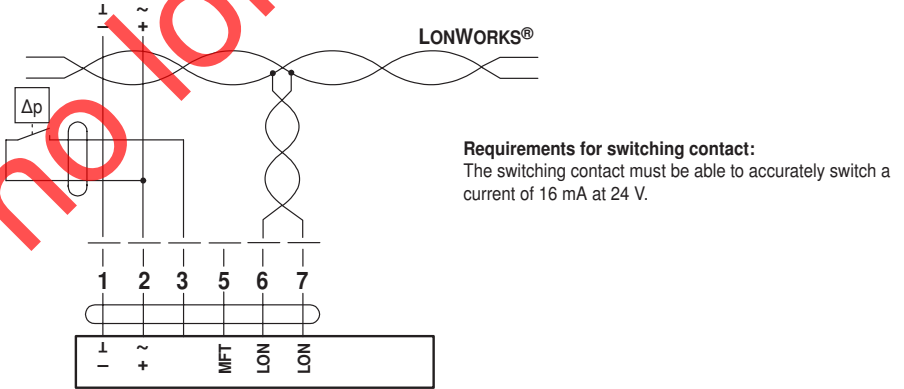

Connection with active sensor, e.g. 0 ... 10 V @ 0 ... 50 °C

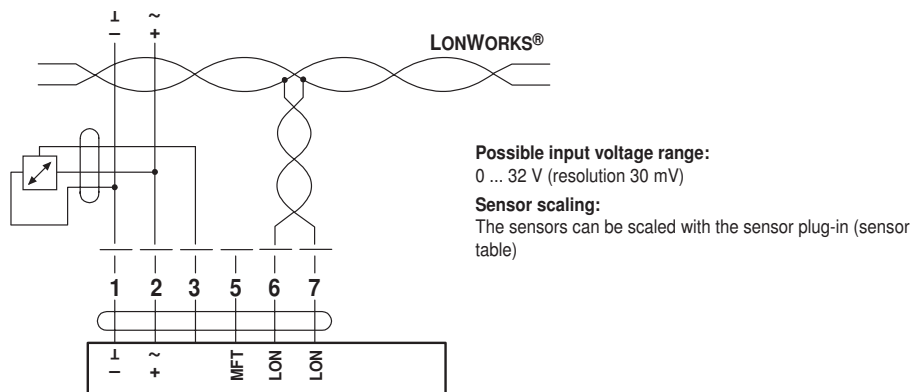

Parameterisation

Connection of the MFT parameterising devices, e.g. Belimo PC-Tool MFT-P

The actuator can be parameterised as follows:

- Electronic angle of rotation limiting
- Torque reduction
- Operation mode cw/ccw
- Running time
- Function test or adaption can be triggered
- Position feedback (measuring voltage U)

Parameterisation of the connected actuator

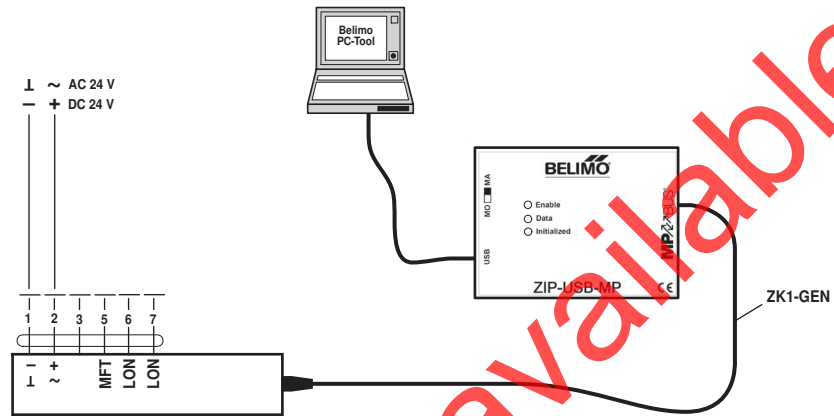

Notes

- The actuator can be triggered with the PC-Tool under "PP".
- The USB cable is included in the ZIP-USB-MP scope of delivery.
- The connection cable ZK1-GEN has to be ordered separately.

Parameterisation of the actuator, Standalone, without AC/DC 24V supply

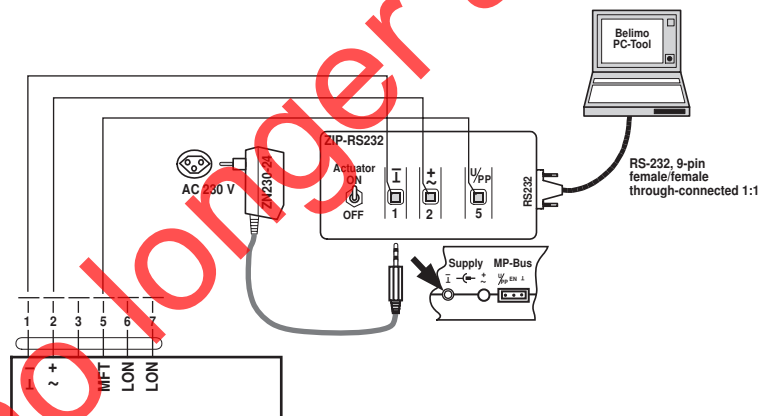

Notes

- The actuator can be triggered with the PC-Tool under "PP".
- The RS-232 cable is included in the ZIP232 scope of delivery.
- The power supply unit ZN230-24 has to be ordered separately.

Operating controls and indicators



- 1 Direction of rotation switch**
Switching over: Direction of rotation changes
- 2 Push-button and green LED display**
Off: No voltage supply or fault
On: Operation
Press button: Switches on angle of rotation adaptation followed by standard operation
- 3 Service button for commissioning with LONWORKS® and LED display yellow for LON status**
Off: The actuator is integrated ready-for-operation in the LONWORKS® network.
On: No application software is loaded in the actuator.
Blinking: The actuator is ready-for-operation, but not integrated in the LONWORKS® network (unconfigured).
(flashing interval 2 s)
Other flashing codes: A fault is present in the actuator.
Press button: Service Pin Message will be sent to the LONWORKS® network.
- 4 Gearing latch key**
Press button: Gear disengaged, motor stops, manual override possible
Release key: Gear engaged, synchronisation starts, followed by standard operation
- 5 Service plug**
For connecting parameterising and service tools

Check voltage supply connection

- a) 2 Off and 3 On
 - b) 2 Blinking and 3 Blinking
- } Check the supply connections.
Possibly ⊥ and ⚡ are swapped over.