

- Globe valves, 2-way, with flange PN 16, actuator with emergency control function
- for closed hot water systems up to 150 °C in district heating applications
 - approved according to EN 14597



Overview of types

Valve with actuator (Ordering text) ¹⁾	k_{vs} [m ³ /h]	DN [mm]	Stroke [mm]	S_v	Δp_s [kPa]	Δp_{max} [kPa]	Δp_{v100} [kPa]	Approval EN 14597
H610S+NVFT24-MFT-E	0.4	15	15	>50	1600	1000		TüV.com-ID
H611S+NVFT24-MFT-E	0.63	15	15	>50	1600	1000		14047
H612S+NVFT24-MFT-E	1.0	15	15	>50	1600	1000		
H613S+NVFT24-MFT-E	1.6	15	15	>50	1600	1000		
H614S+NVFT24-MFT-E	2.5	15	15	>50	1600	1000		
H615S+NVFT24-MFT-E	4.0	15	15	>50	1600	1000		
H619S+NVFT24-MFT-E	4.0	20	15	>100	1600	1000		
H620S+NVFT24-MFT-E	6.3	20	15	>100	1600	1000		
H624S+NVFT24-MFT-E	6.3	25	15	>100	1300	1000		
H625S+NVFT24-MFT-E	10	25	15	>100	1300	1000		
H632S+NVFT24-MFT-E	16	32	15	>100	900	900	800	
H640S+NVFT24-MFT-E	25	40	15	>100	550	550		
H650S+NVFT24-MFT-E	40	50	15	>100	350	350		

¹⁾ The bracket UNV-002 is a scope of delivery component with the Valve + Actuator combination.

Technical data

Valve data	Media
Media	Hot water Water with max. 50% volume of glycol
Medium temperature	+5 °C ... +150 °C
Authorised pressure p_s	1600 kPa (PN 16)
Flow characteristic	Control path A – AB: equal percentage (VDI/VDE 2173) $n(g) = 3$, optimised in the opening range
Rangeability S_v	See «Overview of types»
Leakage rate	max. 0.05 % of the k_{vs} value according to EN 14597
Pipe connectors	Flange according to ISO 7005-2 (PN 16)
Stroke	See «Overview of types»
Closing point	Bottom (▼)

Technical data		(continued)	
Valve data			
Installation position	Standing to lying (in relation to the stem)		
Maintenance	Maintenance-free		
Materials: Fitting	EN-JL1040 (GG 25)		
Valve cone	Stainless steel		
Valve stem	Stainless steel		
Seat	Stainless steel		
Stem seal	PTFE-Roof seal		
Electrical data actuator			
Nominal voltage	AC 24 V, 50/60 Hz / DC 24 V		
Power supply range	AC 19.2 ... 28.8 V / DC 21.6 ... 28.8 V		
Power consumption	In operation	6 W @ 1000 N	
	At rest	2.5 W	
	Dimensioning	10 VA	
Connection	Cable 1 m, 5 x 0.75 mm ²		
Functional data actuator		Factory settings	Variable Setting
Actuating force	Motor	Min. 1000 N @ nominal voltage	
	Spring return	min. 1000 N	
Control	Control signal Y	DC 0 ... 10 V, input impedance 100 kΩ	Open-close, 3-point (AC only)
	Operating range	DC 2 ... 10 V	Start point DC 0.5 ... 30 V End point DC 2.5 ... 32 V
Position feedback (measuring voltage U)	DC 2 ... 10 V, max. 0.5 mA	Start point DC 0.5 ... 8 V End point DC 2.5 ... 10 V	
Running time motor	@ 18 mm	150 s	45 ... 300 s
	@ 15 mm	150 s	35 ... 300 s
Running time spring	@ 18 mm	<27 s	
	@ 15 mm	<23 s	
Sound power level	@ 150 s	Max. 35 dB (A)	
	@ 45 s	Max. 40 dB (A)	
Emergency operation	Max. 50 dB (A)		
Emergency setting position	The valve closes in the deenergised state		
Manual override	Not accessible from outside Self-resetting when cover is removed with Allen key		
Service life	Min. 30,000 emergency settings in accordance with EN 14597		
Position indication	Mechanical 6 ... 20 mm stroke		
Safety (EN 60730-1 and EN 60730-2-14)			
Protection class	III Extra-low voltage		
Degree of protection	IP54 (standing or lying)		
EMC	CE according to 2004/108/EC		
Software class	A		
Mode of operation	Type 1.AA		
Rated impulse voltage	0.8 kV		
Control pollution degree	3		
Hardness testing temperature	83°C		
Ambient temperature	0 ... +50°C		
Medium temperature	+5 ... +150°C (H6..S)		
Non-operating temperature	-40 ... +80°C		
Ambient humidity	95% r.h., non-condensating		
Maintenance	Maintenance-free		

Safety notes

- Valve and actuator are designed for use in stationary heating, ventilation and air conditioning systems and are not allowed to be used outside the specified field of application, especially in aircraft or in any other airborne means of transport.
- They may only be installed by suitably trained personnel. Any legal regulations or regulations issued by government agency authorities must be observed during assembly.
- Valve and actuator do not contain any parts that can be replaced or repaired by the user.
- The valve and actuator may not be disposed of as household refuse. All locally valid regulations and requirements must be observed.
- When determining the flow rate characteristic of controlled devices, the recognised directives must be observed.

Product features

- Mode of operation** The globe valve is operated by an NVFT24 series linear actuator. The actuators are controlled by a commercially available modulating or 3-point control system and move the valve cone, which acts as a throttling device, to the opening position dictated by the control signal. In the nominal widths 65, 80 and 100, the valve is constructed in the same way as the H6..SP series. Higher closing pressures are permitted with the NVFT24.. linear actuator as a result of both the partial pressure relieving stem and the overflow channels in the valve.
- Flow characteristic** An equal-percentage flow characteristic is produced by the profile of the valve cone.
- Manual operation** The valve stem can be manually operated by means of an Allen key (I-6-kt) on the NVFT24 linear actuator. This can be accessed after removing the cover from the linear actuator NVFT24.. and may only be carried out by trained specialist personnel.
- Functional safety** The actuator is secured against short circuits and reverse polarity. The stroke is adapted automatically and is overload protected.

Installation notes

- Recommended installation positions** The globe valves may be mounted in any position from **standing to lying**. It is not permissible to mount the globe valves with the stem pointing downwards.

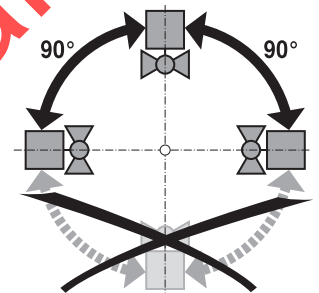

- Water quality requirements**
- The water quality requirements specified in VDI 2035 must be adhered to.
 - Globe valves are regulating devices. The use of **dirt filters** is recommended in order to prolong their service life as modulating instruments.
- Maintenance**
- The globe valves and linear actuators are maintenance-free.
 - Before any kind of service work is carried out on actuator sets of this type, it is essential to isolate the linear actuator from the power supply (by unplugging the power lead if necessary). Any pumps in the part of the piping system concerned must also be switched off and the appropriate isolating fittings closed (allow everything to cool down first if necessary and reduce the pressure in the system to atmospheric).
 - The system must not be returned to service until the globe valve and the linear actuator have been properly reinstalled in accordance with the instructions and the pipeline has been refilled in the proper manner.
- Flow direction** The direction of flow, specified by an arrow on the housing, is to be complied with, since otherwise the large ball valve could be damaged.

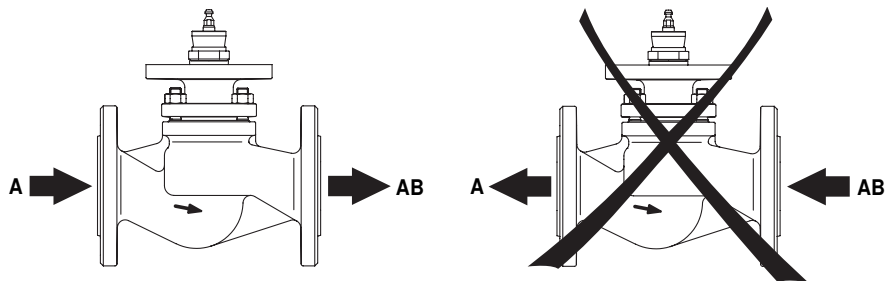

- Definition of differential pressures**
- Δp_s Closing pressure at which the linear actuator can still seal the fitting tightly, with reference to the particular leakage rate.
- Δp_{max} Maximum permitted pressure difference for long service life across control path A – AB referred to the whole range of opening.
- Δp_{v100} Differential pressure with linear globe valve completely open (restriction where Δp_{max} at 100% stroke may only be Δp_{v100}).

Installation notes

(continued)

Insulation regulation

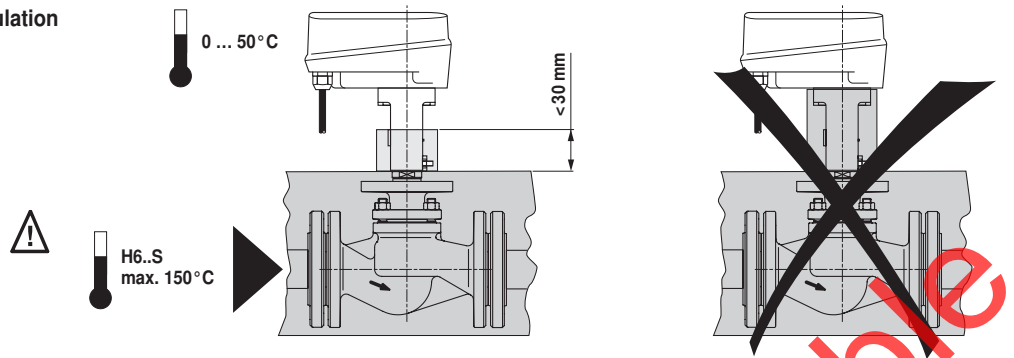

Dimensions and weights

Dimensional drawings

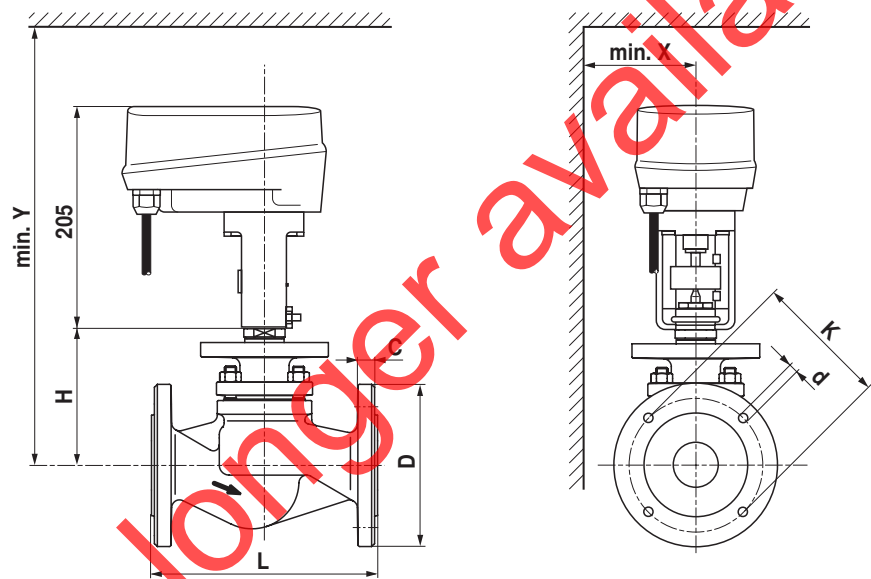

DN [mm]	L [mm]	H [mm]	D [mm]	C [mm]	K [mm]	d [mm]	X ¹⁾ [mm]	Y ¹⁾ [mm]	Weight [kg]
15	130	118	95	14	65	4x14	100	545	3.6
20	150	118	105	16	75	4x14	100	545	4.3
25	160	126	115	16	85	4x14	100	545	5.2
32	180	126	140	18	100	4x18	100	545	6.8
40	200	133	150	18	110	4x18	100	545	8.7
50	230	139	165	20	125	4x18	100	545	11.6

¹⁾ Minimum distance with respect to the valve centre

Electrical installation

Modulating (optionally with feedback)

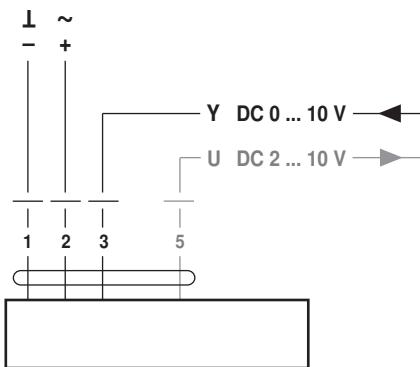

Symbols								Linear spindle moves		
Direction of stroke	Valve closing point	Signal «direct»	Signal «inverted»	Closing point «bottom»	Control signal min. (e.g. Y = 2 V)	Control signal max. (e.g. Y = 10 V)	Measuring signal min. (e.g. U = 2 V)	Measuring signal max. (e.g. U = 10 V)		
	▼	OFF	ON	S3.1	X		X			
				S3.2		X		X	OFF	ON
	▼	ON	ON	S3.1		X		X	ON	ON
				S3.2	X	X			OFF	OFF

If the controller generates a negative signal (<0.15 V), the slide switch S3.1 must not be set to «ON» if the operating range is parameterised by the 2 ... 10 V actuator (Exception: start point in the parameterised operating range of 0.5 V).

3-point parameterised MFT actuator (optional with feedback)

Note

Functions only with nominal voltage AC 24 V! ⚠

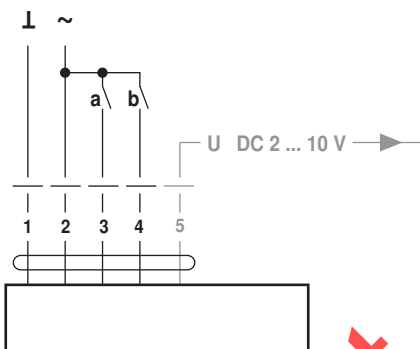

The MFT linear actuator NV.-MFT.. can also be used as a 3-point control.

The linear actuator must however be parameterised for 3-point control and must be provided with a 4-wire connection.

Symbols								Linear spindle moves		
Direction of stroke «3-point»	Valve closing point	Signal «direct»	Signal «inverted»	Closing point «bottom»	Relay contact a (Y1)	Relay contact b (Y2)	Measuring signal min. (e.g. U = 2 V)	Measuring signal max. (e.g. U = 10 V)		
	▽	OFF	ON	S3.1	0	0	*)	*)	stops	stops
				S3.2	1		0	m	ON	ON
	▽	ON	ON	S3.1	1	0	m		ON	OFF
				S3.2	0	1		m	ON	ON

*) Measuring signal U5, depending on position
m: if relay contact a or b is in switch position 150 for longer than the running time (1 s)

Accessories

Electrical accessories

Description	Data sheet
Manual parameterising device MFT-H	T2-MFT-H
PC-Tool MFT-P	T2-MFT-P

Controls



The actuator NVFT.. may be opened only by trained specialist personnel. The manual override and the 24 V electronics are located under the cover.

Manual override

- 1) Disconnect actuator from the supply! The valve moves with the emergency control function (spring) into closed position.
- 2) Releasing the manual override with the NVF24-MFT-E. Rotate the I-6-kt key by approx. 45° in counterclockwise direction until resistance is felt. Afterwards, raise the I-6-kt key (approx. 7 mm), until the black holder for the I-6-kt key is at the same height. The spring package now rotates the I-6-kt key in clockwise direction. The linear spindle now extends completely and the valve closes!
- 3) Actuating the manual override with the NVF24-MFT-E. If the I-6-kt key is rotated in counterclockwise direction, then the linear spindle retracts and must be held in the desired stroke position.
- 4) Locking the manual override with the NVF24-MFT-E. Rotate the I-6-kt key back with a 3/4 turn in clockwise direction and then press into the housing cover (black holder moves approx. 7 mm inward). The manual override is secured by rotating the I-6-kt key slightly in clockwise direction.
- 5) Place actuator at the supply; the locking is released automatically.

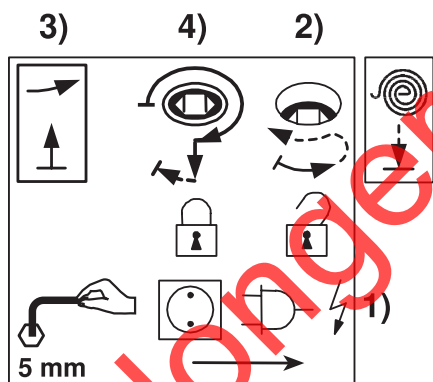

Slide switch/pressure switch

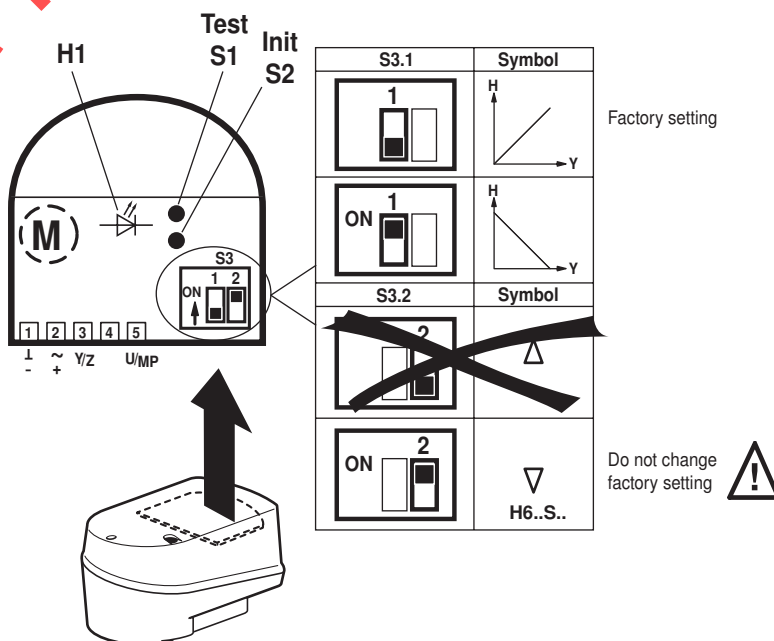

The terminals for the cable connection, the operating elements S1, S2, S3 and the H1 LED indicator are located under the cover of the actuator. By setting slide switch S3 or pressing pushbuttons S1 and S2, it is possible to configure the actuator very simply on site to suit actual requirements, if changes are necessary from the factory settings.



Controls

(continued)

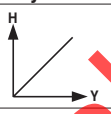
Functional description

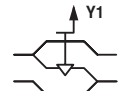
Function	Description	Switch	Symbol	Consequence
Test	The valve effects full stroke with maximum running time and checks the adapted stroke to determine whether the two end-points (H = 0% and H = 100%) are reached.	Press S1		
Init (Adaptation)	The possible stroke effected (between the two mechanical end stops of the valve) is detected a 100% stroke and stored in the microcontroller. The control signal and the running time are then matched to this 100% stroke.	S2 Press		
Direction of stroke	Direction of stroke relative to the control signal	S3.1	Symbol	
direct ¹⁾	0% control signal corresponds to 0% position feedback. (The linear spindle is retracted or extended according to the selected closing point.)	OFF		
inverted	0% control signal corresponds to 100% position feedback. (The linear spindle is extended or retracted according to the selected closing point.)	ON		
Valve closing point down ²⁾	Closing point with linear spindle retracted or extended. The linear spindle is extended from the actuator and the valve stem is retracted into the fitting. The position feedback indicates 0% if the stroke direction is «direct».	S3.2 ON	Symbol 	Consequence 

¹⁾ Factory setting²⁾ Standard setting**Note**

The slide switch S3.2 may not be in any position except ON!

**LED display H1**

The LED display is two-coloured (red/green) and shows the current status of the actuator.

Green steady light	Actuator working properly	
Green flashing light	Test run or adaptation with synchronisation in progress	
Red steady light	A fault is present	Possible causes of malfunctions: – Actuator installed incorrectly – Valve stem blocked – No valve installed The adaptation must be repeated by pressing pushbutton S2 after the malfunction has been eliminated.
Red flashing light	After every voltage interruption (>2 s). The valve is automatically synchronized at the selected closing point the next time it closes, and the LED indicator changes from a red flashing light to a green steady light.	
Alternating red/green flashing light	Addressing via the control system and operation of the adaptation pushbutton S2 in progress	