

Communicative characterised control valve (CCV) with sensor-operated flow control, 2-way, with with PN 16 flange (EPIV)

- Nominal voltage AC/DC 24 V
- Control Modulating
- For closed cold and warm water systems
- For water-side modulating control of air-handling and heating systems
- Communication via BELIMO MP-Bus
- Conversion of active sensor signals and switching contacts

Type overview

Type	DN []	DN ["]	Vnom [l/s]	Vnom [l/min]	kvs theor. [m³/h]	PN []	n(gl) []
P6065W800E-MP	65	2 1/2	8	480	45	16	3.2
P6080W1100E-MP	80	3	11	660	65	16	3.2
P6100W2000E-MP	100	4	20	1200	115	16	3.2
P6125W3100E-MP	125	5	31	1860	175	16	3.2
P6150W4500E-MP	150	6	45	2700	270	16	3.2

kvs theor.: Theoretical kvs value for pressure drop calculation

Technical data

Electrical data	Nominal voltage	AC/DC 24 V
	Nominal voltage frequency	50 Hz
	Nominal voltage range	AC 19.2...28.8 V / DC 21.6...28.8 V
	Power consumption in operation	9.5 W
	Power consumption in rest position	6.5 W
	Power consumption for wire sizing	13 VA
	Connection supply / control	Cable 1 m, 4x 0.75 mm ²
Functional data	Parallel operation	Yes (note the performance data)
	Torque motor	20 Nm (DN 65...80) / 40 Nm (DN 100...150)
	Positioning signal Y	DC 0...10 V
	Operating range Y	DC 2...10 V
	Operating range Y variable	Start point DC 0.5...24 V End point DC 8.5...32 V
	Position feedback U	DC 2...10 V
	Position feedback U variable	Start point DC 0.5...8 V End point DC 2...10 V
	Sound power level motor	45 dB(A)
	Adjustable flow rate Vmax	45...100% of Vnom
	Control accuracy	±10% (of 25...100% Vnom)
	Media	Cold and warm water, water with glycol up to max. 50% vol.
	Medium temperature	-10...120°C
	Permissible pressure ps	1600 kPa
	Closing pressure Δps	690 kPa
	Differential pressure Δpmax	340 kPa
	Flow characteristic	equal percentage (VDI/VDE 2178), optimised in the opening range (switchable to linear)
	Leakage rate	Leakage rate A, air-bubble-tight (EN 12266-1)
Pipe connectors	Flange PN 16 according to EN 1092-2	
Installation position	Upright to horizontal (in relation to the stem)	
Maintenance	Maintenance-free	
Manual override	Gear disengagement with push-button, can be locked	
Flow measurement	Measuring principle	Magnetic inductive volumetric flow measurement
	Measuring accuracy	±6% (of 25...100% Vnom)
	Min. flow measurement	2.5% of Vnom

Technical data

Safety	Protection class IEC/EN	III Safety extra-low voltage
	Degree of protection IEC/EN	IP54
	EMC	CE according to 2004/108/EC
	Mode of operation	Type 1
	Rated impulse voltage supply	0.8 kV
	Control pollution degree	3
	Ambient temperature	-10...50 °C
	Non-operating temperature	-20...80 °C
	Ambient humidity	95% r.h., non-condensing
Materials	Housing	EN-JL1040 (GG25), with protective paint
	Measuring pipe	EN-GJS-500-7U (GGG50 with protective paint)
	Closing element	Stainless steel AISI 316
	Stem	Stainless steel AISI 304
	Stem seal	EPDM Perox
	Valve seat	PTFE, O-ring Viton

Safety notes



- This device has been designed for use in stationary heating, ventilation and air conditioning systems and is not allowed to be used outside the specified field of application, especially in aircraft or in any other airborne means of transport.
- Only authorised specialists may carry out installation. All applicable legal or institutional installation regulations must be complied during installation.
- The connection between the control valve and the measuring tube should not be separated.
- The device contains electrical and electronic components and is not allowed to be disposed of as household refuse. All locally valid regulations and requirements must be observed.

Product features

- Mode of operation** The actuator is comprised of three components: characterised control valve (CCV), measuring pipe with volumetric flow sensor and the actuator itself. The adjusted maximum flow (\dot{V}_{max}) is assigned to the maximum positioning signal (typically 10 V / 100%).
- The actuator control can be either communicative or analogue. The medium is detected by the sensor in the measuring pipe and is applied as the flow value. The measured value is balanced with the setpoint. The actuator corrects the deviation by changing the valve position. The angle of rotation α varies according to the differential pressure through the final controlling element (see volumetric flow curves).

Flow rate curves

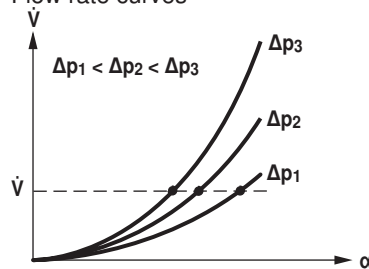

Product features**Flow characteristic of the characterised
control valve**

Heat exchanger transmission behaviour

Depending on the construction, temperature spread, medium and hydraulic circuit, the power Q is not proportional to the water volumetric flow \dot{V} (Curve 1). With the classical type of temperature control, an attempt is made to maintain the control signal Y proportional to the power Q (Curve 2). This is achieved by means of an equal-percentage valve characteristic curve (Curve 3).

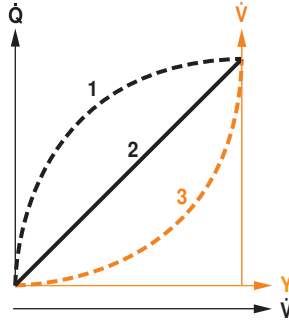

Products no longer available

Product features

Control characteristics

The velocity of the medium is measured in the measuring component (sensor electronics) and converted to a flow rate signal. The positioning signal Y corresponds to the power Q via the exchanger, the volumetric flow is regulated in the EPIV. The control signal Y is converted into an equal-percentage characteristic curve and provided with the \dot{V}_{max} value as the new reference variable w . The momentary control deviation forms the positioning signal Y_1 for the actuator.

The specially configured control parameters in connection with the precise flow rate sensor ensure a stable quality of control. They are however not suitable for rapid control processes, i.e. for domestic water control.

U5 displays the measured volumetric flow as voltage (factory setting). As an alternative, U5 can be used for displaying the valve opening angle. It is always in reference to the respective \dot{V}_{nom} , i.e. if \dot{V}_{max} is e.g. 50% of \dot{V}_{nom} , then $Y = 10\text{ V}$, $U_5 = 5\text{ V}$.

1. Standard equal percentage $V_{max} = V_{nom} / 2$. effect $V_{max} < V_{nom}$

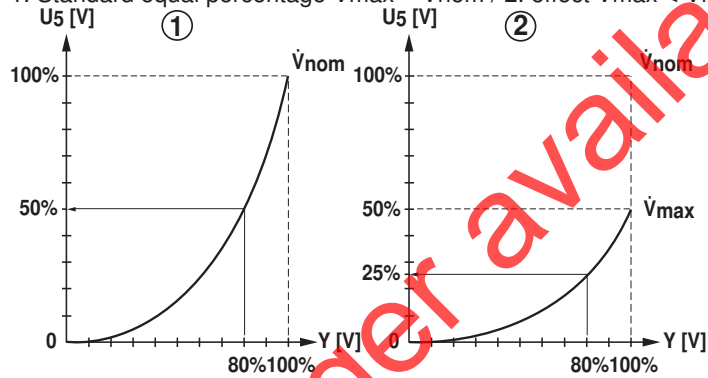

Block diagram

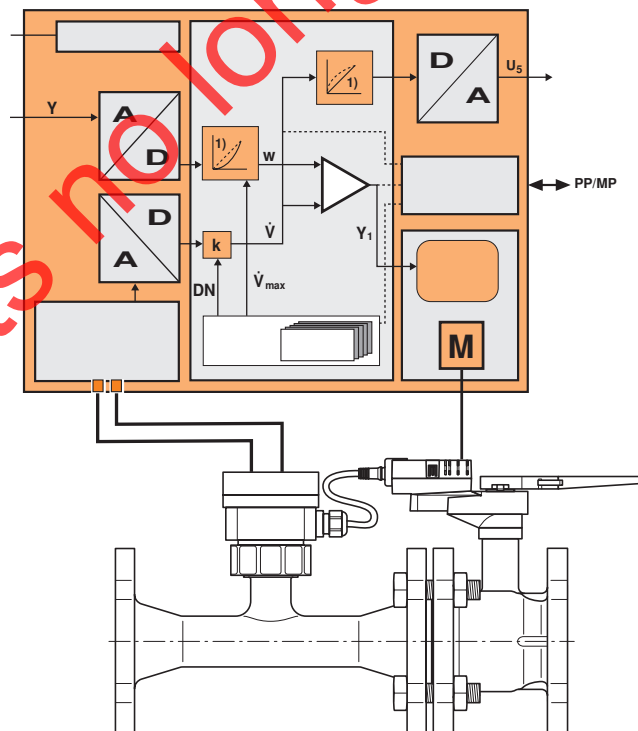

Product features

Definition of flow rate \dot{V}_{nom} is the maximum possible flow.

\dot{V}_{max} is the maximum flow rate which has been set with the greatest positioning signal, e.g. 10 V. \dot{V}_{max} can be set to between 45% and 100% of \dot{V}_{nom} .

\dot{V}_{min} 0% (non-variable).

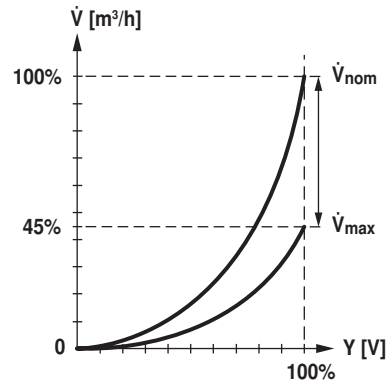

Creep flow suppression Given the very low flow speed in the opening point, this can no longer be measured by the sensor within the required tolerance. This range is overridden electronically.

Opening valve

The valve remains closed until the volumetric flow required by the positioning signal Y corresponds to 2.5% of \dot{V}_{nom} . The control along the valve characteristic curve is active after this value has been exceeded.

Closing valve

The control along the valve characteristic curve is active up to the required flow rate of 2.5% of \dot{V}_{nom} . Once the level falls below this value, the flow rate is maintained at 2.5% of \dot{V}_{nom} . If the level falls below the flow rate of 0.5% of \dot{V}_{nom} required by the reference variable Y, then the valve will close.

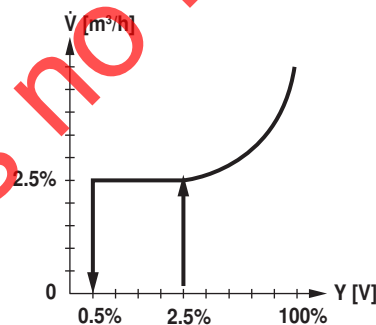

Converter for sensors Connection option for a sensor (active sensor or switching contact). The MP actuator serves as an analogue/digital converter for the transmission of the sensor signal via MP-Bus to the higher level system.

Parameterisable actuators The factory settings cover the most common applications. Input and output signals and other parameters can be altered with the PC-Tool MFT-P or with the Service tool ZTH EU.

Positioning signal inversion This can be inverted in cases of control with an analogue positioning signal. The inversion causes the reversal of the standard behaviour, i.e. at a positioning signal of 0%, regulation is to \dot{V}_{max} , and the valve is closed at a positioning signal of 100%.

Hydraulic balancing With the Belimo-Tools, the maximum flow rate (equivalent to 100% requirement) can be adjusted on-site, simply and reliably, in a few steps. If the device is integrated in the management system, then the balancing can be handled directly by the management system.

Manual override Manual override with push-button possible (the gear is disengaged for as long as the button is pressed or remains locked).

High functional reliability The actuator is overload protected, requires no limit switches and automatically stops when the end stop is reached.

Product features

Home position The first time the supply voltage is switched on, i.e. at the time of commissioning, the actuator carries out an adaption, which is when the operating range and position feedback adjust themselves to the mechanical setting range. After this process the actuator moves into the required position in order to ensure the flow rate defined by the positioning signal.

Accessories

	Description	Type
Gateways	Gateway MP for BACnet MS/TP, AC/DC 24 V	UK24BAC
	Gateway MP to Modbus RTU, AC/DC 24 V	UK24MOD
	Gateway MP for LonWorks®, AC/DC 24 V, LonMark-certified	UK24LON
	Gateway MP to KNX/EIB, AC/DC 24 V, EIBA certified	UK24EIB
Electrical accessories	Description	Type
	Stem heating flange ISO 5211, F05 (30W)	ZR24-F05
	Connecting cable 5 m, A+B: RJ12 6/6, To ZTH/ZIP-USB-MP	ZK1-GEN
	Connection cable 5 m, A: RJ11 6/4, B: Free wire end, To ZTH/ZIP-USB-MP	ZK2-GEN
	Connecting board MP bus suitable for wiring boxes EXT-WR-FP...MP	ZFP2-MP
MP-Bus power supply for MP actuators, AC 230/24V for local power supply	ZN230-24MP	
Service Tools	Description	Type
	Service Tool, for MF/MP/Modbus/LonWorks actuators and VAV-Controller	ZTH EU
	Belimo PC-Tool, software for adjustments and diagnostics	MFT-P
	Adapter to Service-Tool ZTH	MFT-C

Electrical installation



- Notes**
- Connection via safety isolating transformer.
 - Parallel connection of other actuators possible. Note the performance data.

Wiring diagrams

AC/DC 24 V, modulating

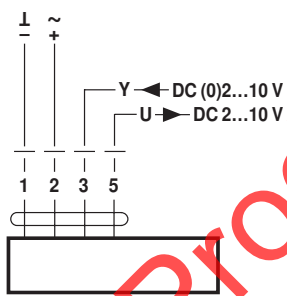

Operation on the MP-Bus

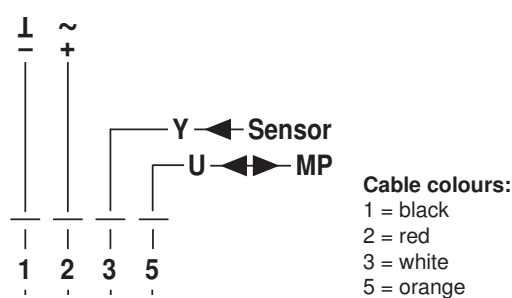

Functions

Functions when operated on MP-Bus

Connection on the MP-Bus

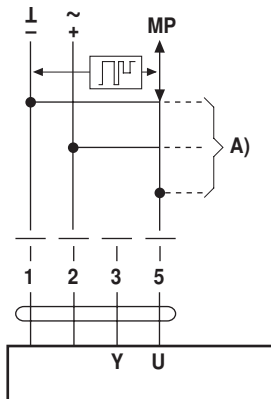

A) Additional actuators and sensors (max. 8)

Power topology

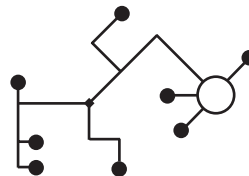

There are no restrictions for the network topology (star, ring, tree or mixed forms are permitted). Supply and communication in the same 3-wire cable

- no shielding or twisting required
- no terminating resistor required

Connection of active sensors

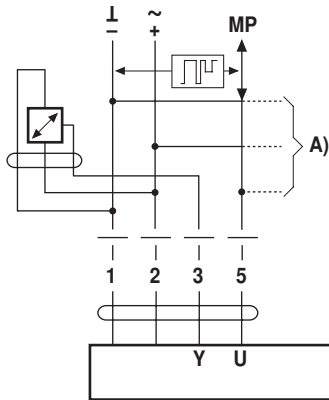

A) Additional actuators and sensors (max. 8)

- Supply AC/DC 24 V
- Output signal DC 0 ... 10 V (max. DC 0 ... 32 V)
- Resolution 30 mV

Connection of external switching contact

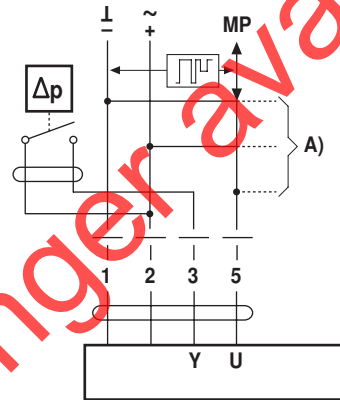

A) Additional actuators and sensors (max. 8)

- Switching current 16 mA @ 24 V
- Start point of the operating range must be parameterised on the MP actuator as ≥ 0.6 V

Functions for actuators with specific parameters (Parametrisation with PC-Tool necessary)

Override control and limitation with AC 24 V with relay contacts

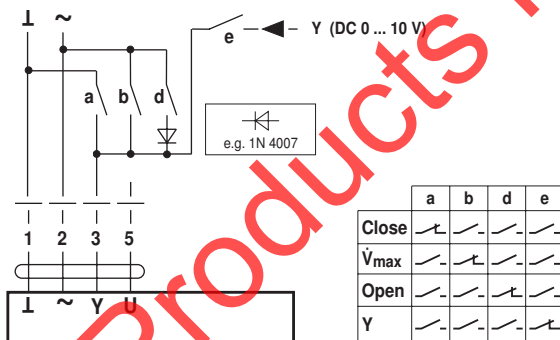

Override control and limitation with DC 24 V with relay contacts

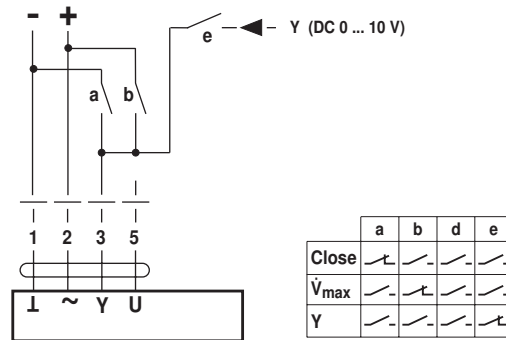

Operating controls and indicators

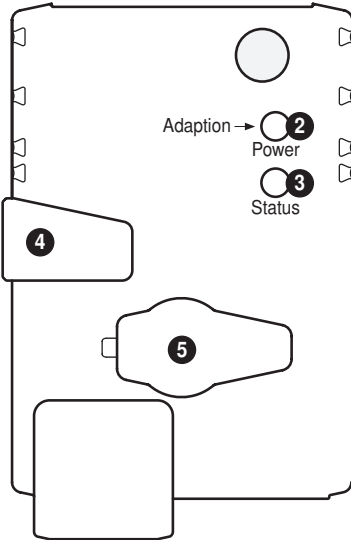

2 Push-button and LED display green

Off: No power supply or malfunction
On: In operation
Press button: Triggers angle of rotation adaptation, followed by standard mode

3 Push-button and LED display yellow

Off: Standard mode without MP-Bus
Flickering: MP communication active
On: Adaptation or synchronising process active
Press button: Confirmation of addressing

4 Gear disengagement button

Press button: Gear disengages, motor stops, manual override possible
Release button: Gear engages, synchronisation starts, followed by standard mode

5 Service plug

For connecting parameterisation and service tools

Check power supply connection

2 Off and 3 On: Possible wiring error in power supply

Installation notes

Recommended installation positions

The ball valve can be installed upright to horizontal. The ball valve may not be installed in a hanging position, i.e. with the stem pointing downwards.

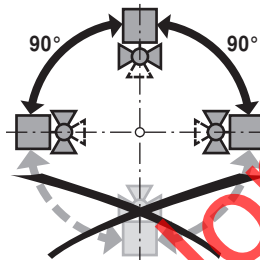

Installation position in return

Installation in the return is recommended.

Water quality requirements

The water quality requirements specified in VDI 2035 must be adhered to. Belimo valves are regulating devices. For the valves to function correctly in the long term, they must be kept free from particle debris (e.g. welding beads during installation work).

The installation of suitable strainer is recommended.

The water must exhibit a conductivity $\geq 20 \mu\text{S}/\text{cm}$ during operation for correct functioning. It should be noted that, under normal circumstances, even filling water with a lower conductivity will experience an elevation of its conductivity to above the minimum required value during filling and that the system can thus be put into operation.

Elevation of conductivity during filling caused by:

- untreated residual water from pressure test or pre-rinsing
- metal salts (e.g. surface rust) dissolved out of the raw material

Stem heating

In cold water applications and warm humid ambient air can cause condensation in the actuators. This can lead to corrosion in the gear box of the actuator and causes a breakdown of it. In such applications, the use of a stem heating is provided. The stem heating must be enabled only when the system is in operation, because it does not have temperature control.

Maintenance

Ball valves, rotary actuators and sensors are maintenance-free.

Before any kind of service work is carried out on the actuator, it is essential to isolate the rotary actuator from the power supply (by unplugging the electrical cable). Any pumps in the part of the piping system concerned must also be switched off and the appropriate slide valves closed (allow everything to cool down first if necessary and reduce the system pressure to ambient pressure level).

The system must not be returned to service until the ball valve and the rotary actuator have been properly reassembled in accordance with the instructions and the pipeline has been refilled in the proper manner.

Installation notes

- Flow direction** The direction of flow, specified by an arrow on the housing, is to be complied with, since otherwise the flow rate will be measured incorrectly.
- Earthing** It is imperative that the measuring pipe be correctly earthed in order to ensure that the volumetric flow sensor does not make any unnecessary incorrect measurements.

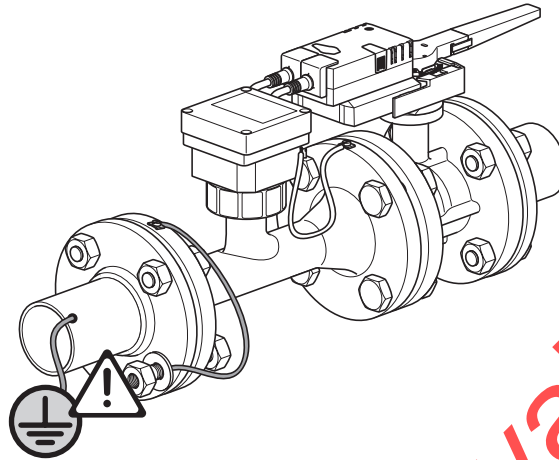

- Inlet section** In order to achieve the specified measuring accuracy, a flow-calming section or inflow section in the direction of the flow is to be provided upstream from the measuring pipe flange. Its dimensions should be at least 5x DN.

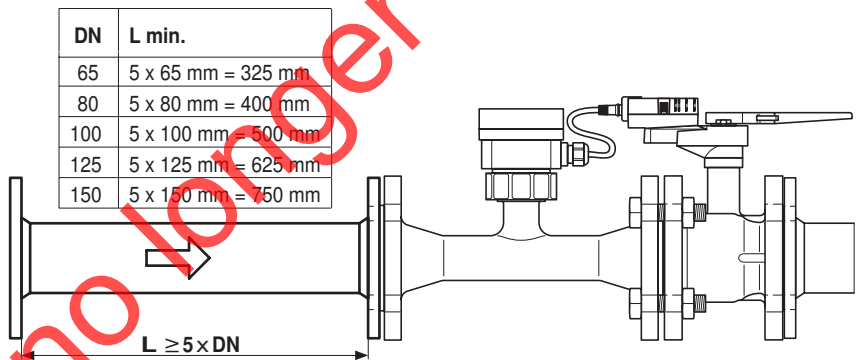

General note

- Valve selection** The valve is determined using the maximum flow required \dot{V}_{max} . A calculation of the kvs value is not required.
 $\dot{V}_{max} = 45 \dots 100\%$ of \dot{V}_{nom}
 If no hydraulic data are available, then the same valve DN can be selected as the heat exchanger nominal diameter.

- Minimum differential pressure (pressure drop)** The minimum required differential pressure (pressure drop through the valve) for achieving the desired volumetric flow \dot{V}_{max} can be calculated with the aid of the theoretical kvs value (see type overview) and the below-mentioned formula. The calculated value is dependent on the required maximum volumetric flow \dot{V}_{max} . Higher differential pressures are compensated for automatically by the valve.

Formula

$$\Delta p_{min} = 100 \times \left(\frac{\dot{V}_{max}}{k_{vs \text{ theor.}}} \right)^2$$

$\Delta p_{min}: \text{kPa}$
 $\dot{V}_{max}: \text{m}^3/\text{h}$
 $k_{vs \text{ theor.}}: \text{m}^3/\text{h}$

Example (DN100 with the desired maximum flow rate = 50% \dot{V}_{nom})
 P6100W2000E-MP
 $k_{vs \text{ theor.}} = 115 \text{ m}^3/\text{h}$
 $\dot{V}_{nom} = 1200 \text{ l/min}$
 $50\% \times 1200 \text{ l/min} = 600 \text{ l/min} = 36 \text{ m}^3/\text{h}$

$$\Delta p_{min} = 100 \times \left(\frac{\dot{V}_{max}}{k_{vs \text{ theor.}}} \right)^2 = 100 \times \left(\frac{36 \text{ m}^3/\text{h}}{115 \text{ m}^3/\text{h}} \right)^2 = 10 \text{ kPa}$$

Dimensions / Weight

Dimensional drawings

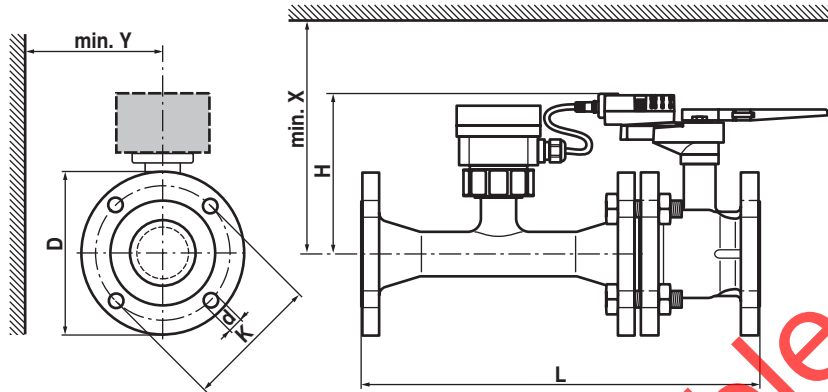

If Y < 180 mm, then the extension of the hand crank must be dismantled as necessary.

Type	DN []	L [mm]	H [mm]	D [mm]	d [mm]	K [mm]	X [mm]	Y [mm]	Weight approx. [kg]
P6065W800E-MP	65	454	200	185	4 x 19	145	220	150	25
P6080W1100E-MP	80	499	200	200	8 x 19	160	220	160	30
P6100W2000E-MP	100	582	220	229	8 x 19	180	240	175	47
P6125W3100E-MP	125	640	240	252	8 x 19	210	260	190	58
P6150W4500E-MP	150	767	240	282	8 x 23	240	260	200	73

Further documentation

- General notes for project planning

Products no longer available