

Range controller, suitable for modulating actuators LM24A-SR, NM24A-SR, SF24A-SR, SM24A-SR and GM24A-SR



## Technical data

<b>Electrical data</b>	Nominal voltage	AC 24 V, 50/60 Hz	
	Nominal voltage range	AC 21.6 ... 27.6 V	
	Power consumption	1 W + connected actuators	
	For wire sizing	1.5 VA + connected actuators	
	Connection	Terminals	
<b>Functional data</b>	Control signal Y	Y1: DC 0 ... 10 V Y2: 0 ... 20 V phasecut	
	Input impedance	Y <sub>1</sub> : 100 kΩ (0,1 mA) Y <sub>2</sub> : 8 kΩ (50 mW)	
	Operating range	Y1: DC 2 ... 10 V Y2: 2 ... 10 V phasecut	
	Direction of rotation	Reversible (direct / reverse acting)	
	Positioning range	Adjustable Max. = 0.2 ... 1 (~20 ... 90° rotation ↺) Min. = 0 ... 80% of Max.	
	Override control	↓ to terminal 6 = position 0 (closed) ~ to terminal 6 = position 1 (open)	
	Measuring voltage U	DC 2 ... 10 V (max. 0.5 mA) for position 0 ... 1	
	Output actuator	Terminal 3: DC 2 ... 10 V (max. 0.5 mA)	
	<b>Safety</b>	Protection class	III Safety extra-low voltage
		Degree of protection	IP40
EMC		CE according to 89/336/EWG	
Mode of operation		Type 1 (to EN 60730-1)	
Ambient temperature		-20 ... +50 °C	
Humidity test		To EN 60730-1	
Maintenance	Maintenance free		
<b>Dimensions / Weight</b>	Dimensions	See «Dimensions» on page 2	
	Weight	Approx. 400 g	

## Safety notes



- The range controller is not allowed to be used outside the specified field of application, especially not in aircraft or any other form of air transport.
- Assembly must be carried out by trained personnel. Any legal regulations or regulations issued by authorities must be observed during assembly.
- The device may only be opened at the manufacturer's site. It does not contain any parts that can be replaced or repaired by the user.
- The device contains electrical and electronic components and is not allowed to be disposed of as household refuse. All locally valid regulations and requirements must be observed.

Product features

**Application** In central air handling units and other ducted systems, multiblade-dampers are mainly used as control and mixing dampers. The control characteristics of dampers, however, depend upon many factors. Even with correctly sized dampers and fans it is only possible to adjust the air volume with a universal adjustment kit. With the range controller SBG24, this is easily achieved, since the working range (I) of the dampers can be defined by the Min.-Max. setting potentiometer. The SBG24 is usually installed close to the damper actuator (and at the same time used as connection box).

Device description

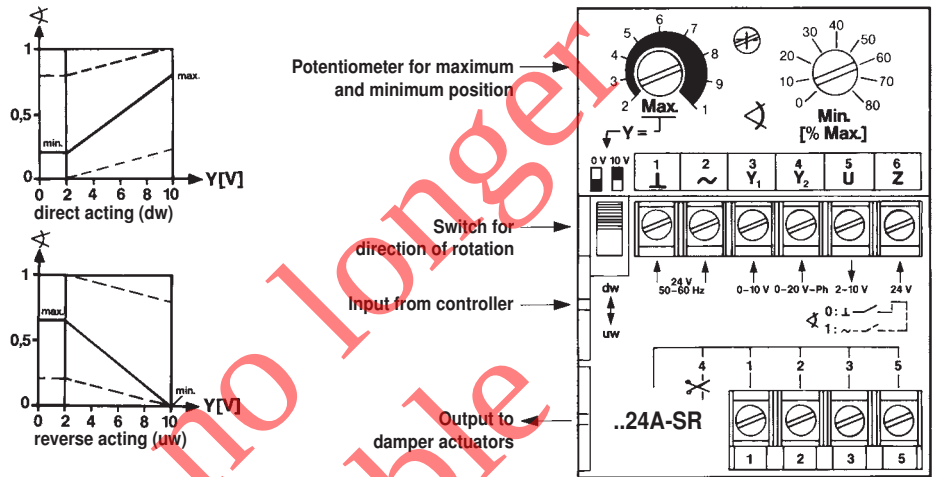

Electrical installation

Wiring diagram

**Note** Connection via safety isolating transformer.

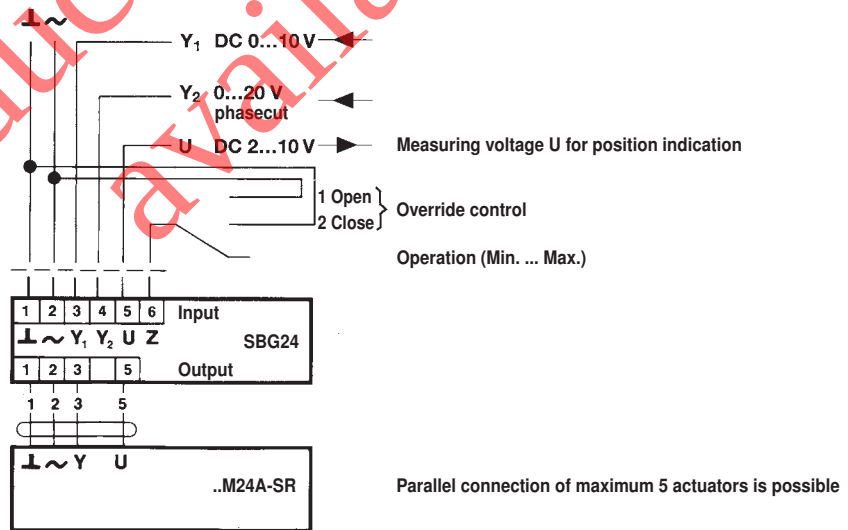

Dimensions [mm]

Dimensional drawings

