

Communicative rotary actuator for rotary valves and butterfly valves

- Torque motor 20 Nm
- Nominal voltage AC/DC 24 V
- Integrated temperature controller
- Communication via LONWORKS® (FTT-10A)
- Conversion of sensor signals

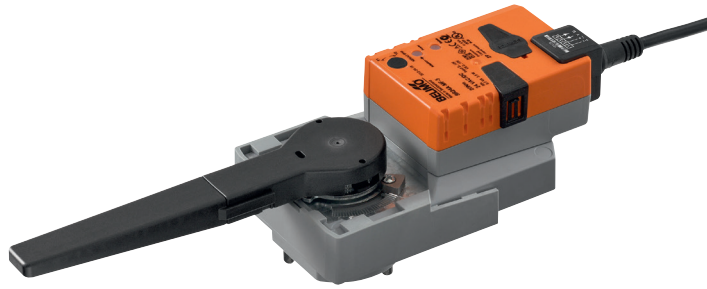

LONMARK®

**Technical data**

<b>Electrical data</b>	Nominal voltage	AC/DC 24 V	
	Nominal voltage frequency	50/60 Hz	
	Nominal voltage range	AC 19.2...28.8 V / DC 21.6...28.8 V	
	Power consumption in operation	4 W	
	Power consumption in rest position	1.25 W	
	Power consumption for wire sizing	6 VA	
	Connection supply / control	Cable 1 m, 6 x 0.75 mm <sup>2</sup>	
<b>Data bus communication</b>	Certified	According to LonMark 3.3	
	Processor	Neuron 3150	
	Transceiver	FTT-10A	
	Functional Profile as per LONMARK®	Damper Actuator Object #8110Open Loop Sensor Object #1Thermostat Object #8060	
	LNS plug-in for actuator / sensor / controller	Can be run with any LNS-based integration tool (Min. for LNS 3.x)	
	Service button and status LED	According to LonMark guidelines	
	Conductors, cables	Signal cable lengths, cable specifications and topology of the LonWorks network in accordance with the Echelon guidelines	
<b>Functional data</b>	Torque motor	20 Nm	
	Position accuracy	±5%	
	Manual override	with push-button, can be locked	
	Running time motor	90 s / 90°	
	Running time motor variable	90...350 s	
	Adaptation setting range	manual (automatic on first power-up)	
	Override control, controllable via nManOvrd	MAX (maximum position) = 100% MIN (minimum position) = 0% ZS (intermediate position) = 50%	
	Sound power level, motor	45 dB(A)	
	Position indication	Mechanically, integrated, two-section	
	<b>Safety</b>	Protection class IEC/EN	III Safety Extra-Low Voltage (SELV)
		Protection class UL	UL Class 2 Supply
		Degree of protection IEC/EN	IP54
		Degree of protection NEMA/UL	NEMA 2
Enclosure		UL Enclosure Type 2	
EMC		CE according to 2014/30/EU	
Certification IEC/EN		IEC/EN 60730-1 and IEC/EN 60730-2-14	
Certification UL		cULus according to UL60730-1A, UL60730-2-14 and CAN/CSA E60730-1:02	
Certification UL note		The UL marking on the actuator depends on the production site, the device is UL-compliant in any case	
Mode of operation		Type 1	
Rated impulse voltage supply / control	0.8 kV		
Control pollution degree	3		
Ambient temperature	-30...50 °C		
Storage temperature	-40...80 °C		
Ambient humidity	Max. 95% r.H., non-condensing		
Servicing	maintenance-free		

## Technical data

<b>Mechanical data</b>	Connection flange	F05
<b>Weight</b>	Weight	1.2 kg

## Safety notes



- This device has been designed for use in stationary heating, ventilation and air-conditioning systems and must not be used outside the specified field of application, especially in aircraft or in any other airborne means of transport.
- Outdoor application: only possible in case that no (sea) water, snow, ice, insolation or aggressive gases interfere directly with the actuator and that is ensured that the ambient conditions remain at any time within the thresholds according to the data sheet.
- Only authorised specialists may carry out installation. All applicable legal or institutional installation regulations must be complied during installation.
- The switch for changing the direction of rotation may only be operated by authorised specialists. The direction of rotation must not in particular be reversed in a frost protection circuit.
- The device may only be opened at the manufacturer's site. It does not contain any parts that can be replaced or repaired by the user.
- Cables must not be removed from the device.
- The device contains electrical and electronic components and must not be disposed of as household refuse. All locally valid regulations and requirements must be observed.

## Product features

<b>Mode of operation</b>	The actuator is equipped with an integrated interface for LONWORKS®. The actuator can be directly connected to the LON network and controlled via the transceiver FTT-10A.
<b>Converter for sensors</b>	Connection option for a sensor (passive or active sensor or switching contact). In this way, the analogue sensor signal can be easily digitised and passed along to LONWORKS®.
<b>Integrated temperature controller</b>	The device has an integrated temperature controller (Thermostat Object LONMARK® #8060). Other control variants upon request. The temperature controller can be set using the LNS Plug-In from Belimo.
<b>Parametrisable actuators</b>	The factory settings cover the most common applications. Single parameters can be modified with the Belimo Service Tools MFT-P or ZTH EU.
<b>Simple direct mounting</b>	Simple direct mounting on the rotary valve or butterfly valve with mounting flange. The mounting orientation in relation to the fitting can be selected in 90° steps.
<b>Manual override</b>	Manual override with push-button possible (the gear is disengaged for as long as the button is pressed or remains locked).
<b>Adjustable angle of rotation</b>	Adjustable angle of rotation with mechanical end stops.
<b>High functional reliability</b>	The actuator is overload protected, requires no limit switches and automatically stops when the end stop is reached.
<b>Combination valve/actuator</b>	For valves with the following mechanical specifications in accordance with ISO 5211 F05: - Square stem head SW = 14 mm for form-fit coupling of the rotary actuator. - Hole circle d = 50 mm
<b>Home position</b>	The first time the supply voltage is switched on, i.e. at the time of commissioning, the actuator carries out an adaption, which is when the operating range and position feedback adjust themselves to the mechanical setting range. The actuator then moves into the position defined by the positioning signal. Factory setting: Y2 (counter-clockwise rotation).

**Product features**

**Adaption and synchronisation** An adaption can be triggered manually by pressing the “Adaption” button or with the PC-Tool. Both mechanical end stops are detected during the adaption (entire setting range).  
Automatic synchronisation after pressing the gearbox disengagement button is configured. The synchronisation is in the home position (0%).  
The actuator then moves into the position defined by the positioning signal.  
A range of settings can be adapted using the PC-Tool (see MFT-P documentation)

**Accessories**

	Description	Type
<b>Electrical accessories</b>	Connection cable 5 m, A: RJ11 6/4 ZTH EU, B: 6-pin service socket for Belimo device	ZK4-GEN
	Connection cable 5 m, A: RJ11 6/4 ZTH EU, B: free wire end for connection to MP/PP terminal	ZK2-GEN
<b>Service Tools</b>	Service Tool, Setting tool with ZIP-USB function	ZTH EU
	Belimo PC-Tool, Software for adjustments and diagnostics	MFT-P
	Adapter for Service-Tool ZTH	MFT-C

**Electrical installation**

**Notes**

- Connection via safety isolating transformer.
- Direction of rotation switch is covered. Factory setting: Direction of rotation Y2.

**Wiring diagrams**

Connection without sensor

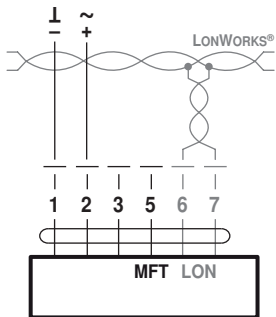

Connection with passive sensor, e.g. Pt1000, Ni1000, NTC

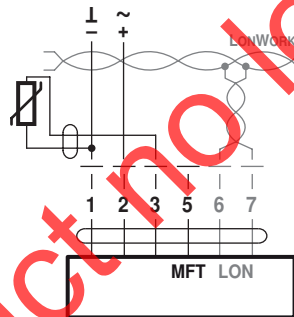

Ni1000	-28...+98°C	850...1600 Ω <sup>2)</sup>
PT1000	-35...+155°C	850...1600 Ω <sup>2)</sup>
NTC	-10...+160°C <sup>1)</sup>	200 Ω...60 kΩ <sup>2)</sup>

**Sensor scaling:**  
The sensors can be scaled with the sensor plug-in (sensor table).  
1) Depending on type  
2) Resolution 1 Ohm

Connection with active sensor, e.g. 0...10 V @ 0...50°C

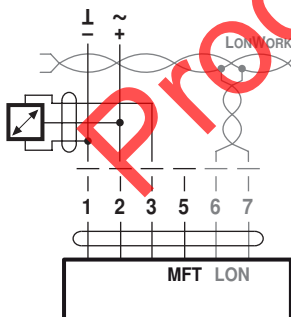

Possible voltage range:  
0...32V (Resolution 30 mV)  
**Sensor scaling:**  
The sensors can be scaled with the sensor plug-in (sensor table)

Connection with switching contact, e.g. Δp monitor

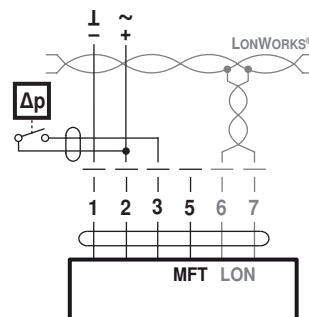

**Switching contact requirements:**  
The switching contact must be able to switch a current of 16 mA at 24 V accurately.

**Functional Profile as per LONMARK®**

The LON-capable actuator is certified by LONMARK®. The following actuator functions are made available via the LONWORKS® network as standardised network variables in accordance with LONMARK®: the Node Object #0, the Damper Actuator Object #8110, the Open Loop Sensor Object #1 and the Thermostat Object #8060.

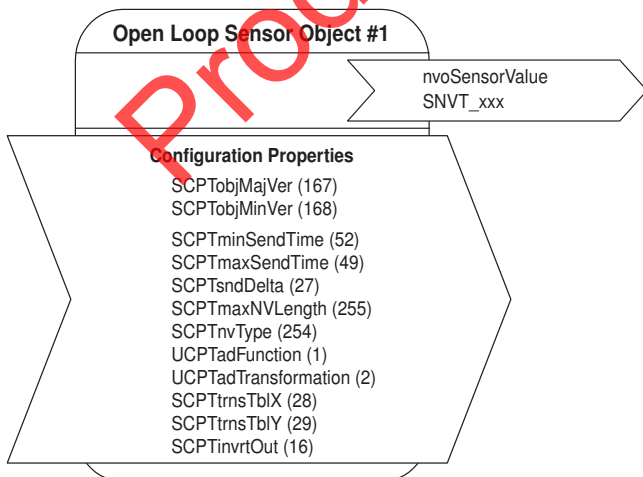
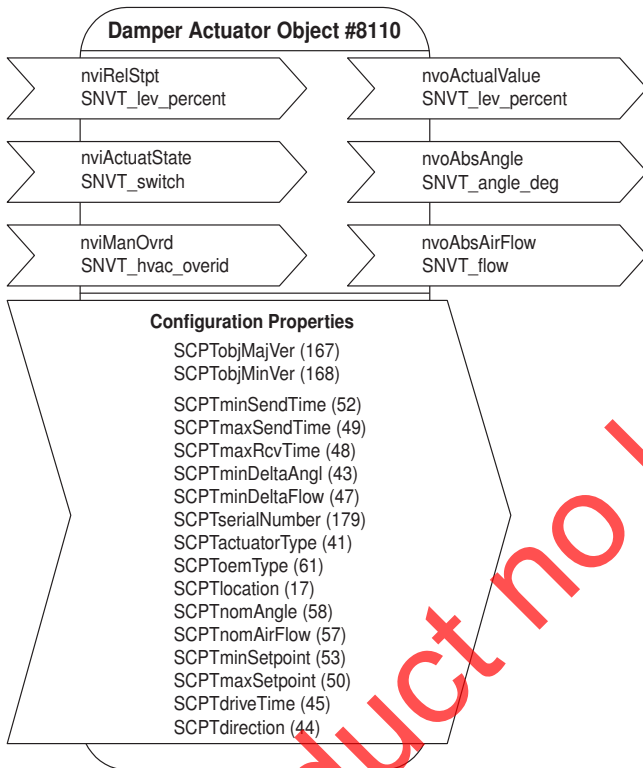
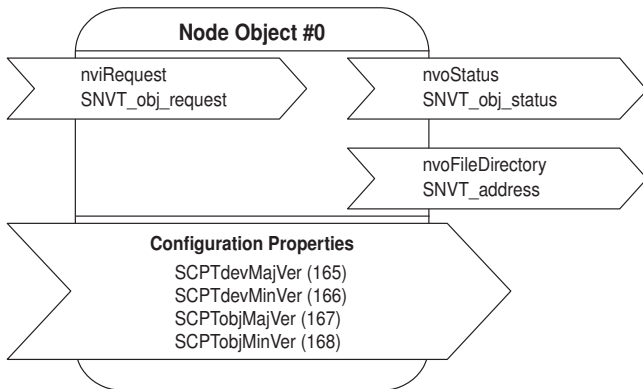

**Node Object #0**

The node object contains the object status and object request functions.

**nviRequest: SNVT\_obj\_request**

Input variable for requesting the status of a particular object in the node.

**nvoStatus: SNVT\_obj\_status**

Output variable that outputs the current status of a particular object in the node.

**nvoFileDirectory: SNVT\_address**

Output variable that shows information in the address range of the Neuron chip.

**Damper Actuator Object #8110**

The actuator object is used to display the functions of the actuator on the page of the LONWORKS® network.

**nviRelStpt: SNVT\_lev\_percent**

Via this input variable, the setpoint in % for the actuator is specified (0...100% = Min...Max). This variable is normally linked to the output variable of an HVAC controller.

**nviActuateState: SNVT\_switch**

A preset position is assigned to the actuator via this input variable. Note on priority: The variable which was most recently active, either nviActuatorState or nviRelStpt, has priority.

**nviManOvrd: SNVT\_hvac\_overid**

see table «Override control with SNVT nviManOvrd»

**nvoActualValue: SNVT\_lev\_percent**

This output variable shows the current actual position of the actuator and can be used for control circuit feedback or for displaying positions.

**nvoAbsAngle: SNVT\_angle\_deg**

This output variable shows the current angle of rotation / stroke of the actuator and can be used to display the position or for service purposes.

**nvoAbsAirFlow: SNVT\_flow**

This output variable is inactive with this actuator and shows a constant value of 65535 (this variable is only active in conjunction with LON-capable VAV controllers).

**Open Loop Sensor Object #1**

One sensor can be connected to the actuator.

A passive resistance sensor (e.g. Ni1000), an active sensor (output 0...32 V) or a switch (On/Off) can be connected. In the case of the open loop sensor object, the measured sensor values are transferred to the LONWORKS® network.

**nvoSensorValue: SNVT\_XXX**

This output variable shows the current sensor value. Depending on the connected sensor, the output variable can be configured via the sensor plug-in and specifically adapted to the system.

**The SNVT .. can be configured as:**

SNVT_temp_p	SNVT_lev_percent	SNVT_lux
SNVT_temp	SNVT_abs_humid	SNVT_press_p
SNVT_switch	SNVT_enthalpy	SNVT_smo_obscur
SNVT_flow	SNVT_ppm	SNVT_power
SNVT_flow_p	SNVT_rpm	SNVT_elec_kwh

**Functional Profile as per LONMARK®**

Individual room control solutions can be implemented with the thermostat object LONMARK® #8060. An LNS plug-in is available for configuring the controller parameters.

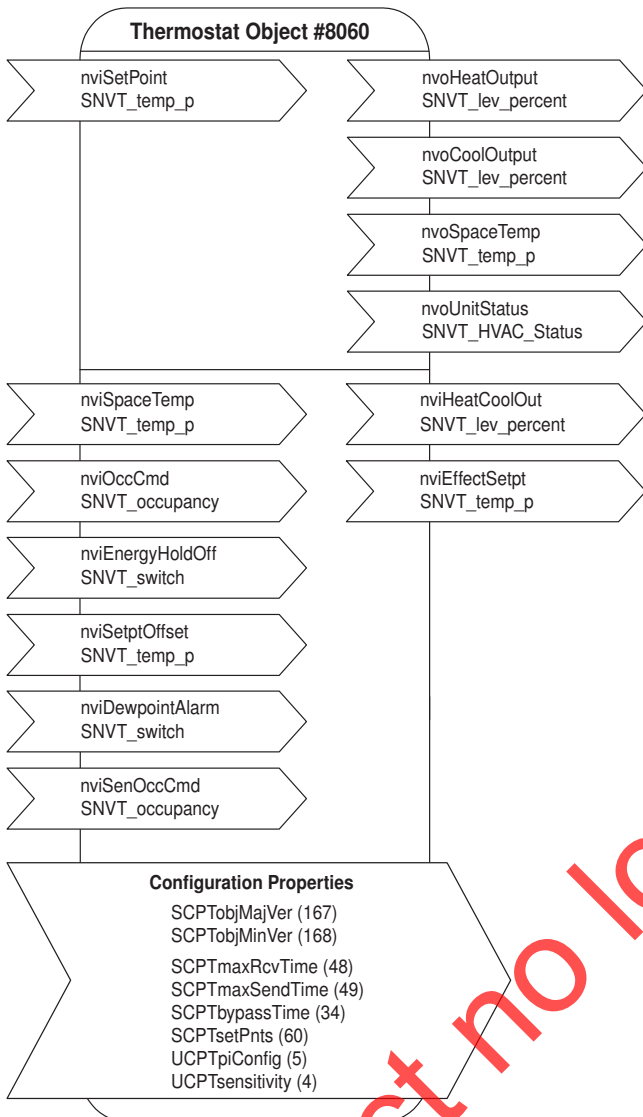
**Note**

A restart is necessary after accessing network variables for the purpose of rewriting them or after deleting links in order to initialise the variables.

**Thermostat Object #8060**
**nviSetPoint: SNVT\_temp\_p**

Setpoint specification for the controller from the higher-level system or the room control unit. If this variable is not linked, then the local setpoints of the controller object apply (can be adjusted via plug-in). The setpoint specification from the higher-level system influences the setting on the controller as follows:

*Example: Comfort setpoint for heating = 21 °C and Comfort setpoint for cooling = 23 °C. The median point between heating and cooling is thus 22 °C. Now, if the external setpoint (nviSetPoint) is 23 °C, then the heating setpoint will shift to 22 °C and the cooling set point to 24 °C. The setpoints for Pre-Comfort heating and cooling will also be shifted accordingly.*

**nviSpaceTemp: SNVT\_temp\_p**

Room temperature from external room sensor. It is imperative that this variable be linked; typically, it is linked with the variable of the sensor object.

**nviOccCmd: SNVT\_occupancy**

Occupancy specification from the command centre (for the function, see the table entitled «Functions Inputs Occupancy» next page).

**nviEnergyHoldOff: SNVT\_switch**

In the case of active EnergyHoldOff, the controller will be set to the Building Protection setpoints.

**nviSetPtOffset: SNVT\_temp\_p**

Shifting of the room control unit. If the nviSetPoint is linked, then this input has an influence on the variable value of nviSetPoint, i.e. it corrects it. Otherwise, the Comfort and Pre-Comfort setpoints for heating and cooling will be adjusted directly by the amount of the shift (compare example with nviSetPoint).

**nviDewpointAlarm: SNVT\_switch**

In the case of active DewpointAlarm, the controller will be set to the Building Protection setpoints. The cooling sequence is deactivated.

**nviSenOccCmd: SNVT\_occupancy**

Occupancy specification from the local occupancy switch (for the function, see the table entitled «Functions Inputs Occupancy» next page).

**nvoHeatOutput: SNVT\_lev\_percent**

Control signal for heating.

**nvoCoolOutput: SNVT\_lev\_percent**

Control signal for cooling.

**nvoSpaceTemp: SNVT\_temp\_p**

Displays the room temperature of the nviSpaceTemp. If nviSpaceTemp is not linked, then the variable will display the value 0x7FFF.

**nvoUnitStatus: SNVT\_HVAC\_Status**

Displays the operating mode of the controller (in accordance with Functional Profile #8060).

**nvoHeatCoolOut: SNVT\_lev\_percent**

Depicts the heating and cooling sequence for controlling the 6-way characterised control valves (see illustration, next page).

This outlet runs parallel to the nvoCoolOutput or the nvoHeatOutput, respectively.

Cooling = 33...0%

Valve closed 33...66%

Heating = 66...100%

**nvoEffectSetpt: SNVT\_temp\_p**

Shows the actual setpoint of the controller.

Functional Profile as per LONMARK®

Functions Inputs Occupancy

Occupancy specification from nviOccCmd command centre	Occupancy switch nviSenOccCmd	Room operating status	Comfort extension
OC_OCCUPIED	OC_OCCUPIED	Comfort	
	OC_UNOCCUPIED	Comfort	
	OC_NUL (default)	Comfort	
OC_STANDBY	OC_OCCUPIED	Bypass	Occupied time is extended by the amount of the bypass time (comfort time) (can be adjusted in the plug-in)
	OC_UNOCCUPIED	Pre-Comfort	
	OC_NUL (default)	Pre-Comfort	
OC_UNOCCUPIED	OC_OCCUPIED	Building Protection	
	OC_UNOCCUPIED	Building Protection	
	OC_NUL (default)	Building Protection	
OC_NUL (default)	OC_OCCUPIED	Comfort	
	OC_UNOCCUPIED	Pre-Comfort	
	OC_NUL (default)	Comfort	

**Note**  
The function nviOccCmd has a higher priority than the function nviSenOccCmd.

Funktion nvoHeatCoolOut

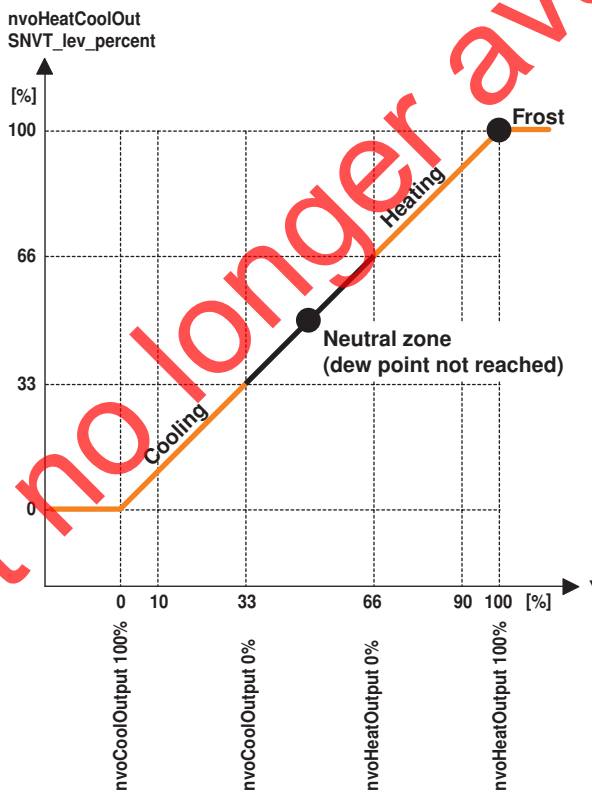

**Typical application**  
Heating / cooling with Belimo 6-way characterised control valve.

**Note chilled ceiling application**  
In the case of active DewPointAlarm (nviDewPointAlarm), the controller will be set to the Building Protection setpoints. The cooling sequence is deactivated.

Override control with the SNVT nviManOvr

State	Value	Actuator
HVO_OFF	–	Override control inactive
HVO_POSITION	percent	Position in % (MIN...MAX)
HVO_FLOW_VALUE	flow	–
HVO_FLOW_PERCENT	percent	–
HVO_OPEN	–	Full open
HVO_CLOSE	–	Full closed
HVO_MINIMUM	–	Minimum position
HVO_MAXIMUM	–	Maximum position

**Note**  
The basic setting is «HVO\_OFF». This value is loaded when the power supply is switched on.

**Note**  
More detailed information on the functional profiles can be found on the website of LONMARK®. ([www.lonmark.org](http://www.lonmark.org)).

## Operating controls and indicators

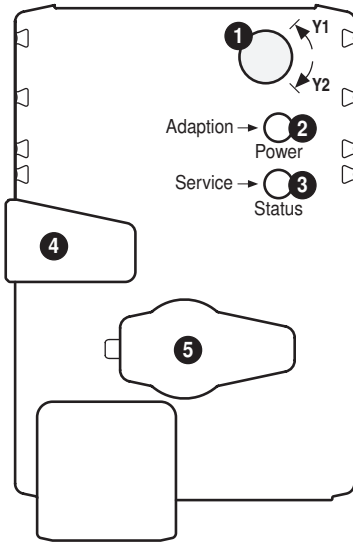

- 1 Direction of rotation switch**  
 Switch over: Direction of rotation changes
- 2 Push-button and LED display green**  
 Off: No power supply or malfunction  
 On: In operation  
 Press button: Triggers angle of rotation adaptation, followed by standard mode
- 3 Service button for commissioning at LONWORKS® and LED display yellow for LON status**  
 Off: The actuator is linked to the LONWORKS® and ready for operation  
 On: No application software is loaded in the actuator  
 Flashing, interval 2 s: The actuator is ready for operation, but not linked to the LONWORKS®  
 Other flashing codes: There is a malfunction in the actuator  
 Press button: Service Pin Message is sent to the LONWORKS®
- 4 Gear disengagement button**  
 Press button: Gear disengages, motor stops, manual override possible  
 Release button: Gear engages, synchronisation starts, followed by standard mode
- 5 Service plug**  
 For connecting parameterisation and service tools

## Service

**Service Tools connection** The actuator can be parametrised by ZTH EU via the service socket. For an extended parameterisation the PC tool can be connected.

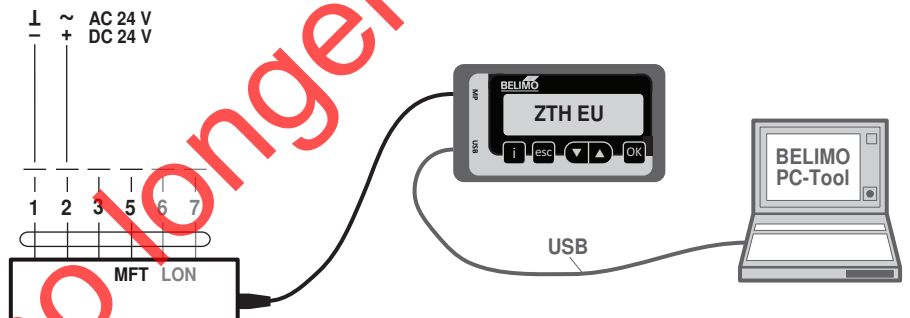

## Dimensions [mm]

### Dimensional drawings

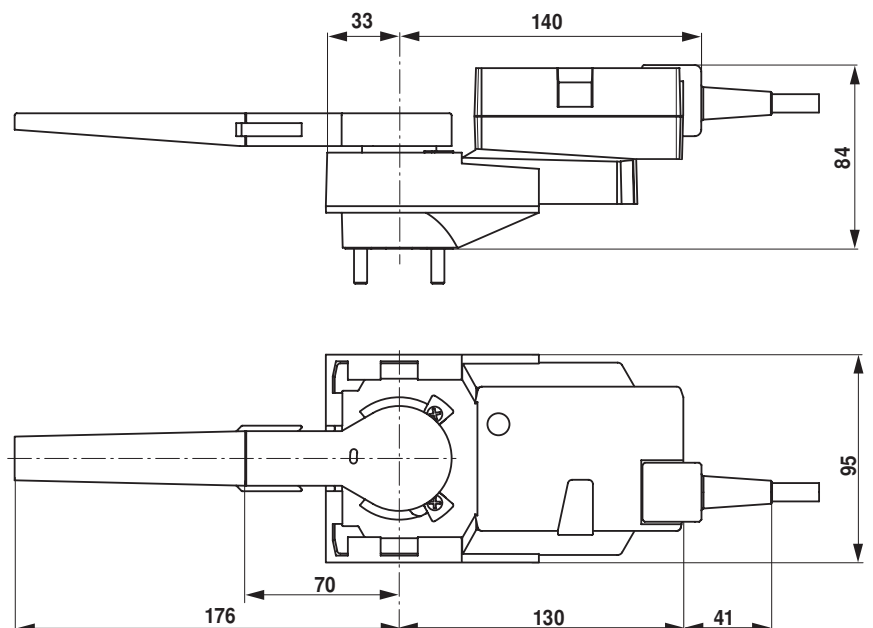

**Further documentation**

- Applications with integrated temp. controller
- LON actuators with CO<sub>2</sub> control
- Actuator Plug-in description
- Sensor Plug-in description
- Controller Plug-in description
- Tool connections
- LonWorks® Glossary

Product no longer available