

Duct/Immersion sensor Temperature

Active sensor (0...10 V) for measuring temperature in duct applications. In combination with a stainless steel or brass thermowell which is also applicable for pipe applications. IP65 / NEMA 4X rated enclosure.

Type Overview

Type	Output signal active temperature	Probe length	Probe diameter
22DT-12H	0...5 V, 0...10 V	50 mm	6 mm
22DT-12L	0...5 V, 0...10 V	100 mm	6 mm
22DT-12N	0...5 V, 0...10 V	150 mm	6 mm
22DT-12P	0...5 V, 0...10 V	200 mm	6 mm
22DT-12R	0...5 V, 0...10 V	300 mm	6 mm
22DT-12T	0...5 V, 0...10 V	450 mm	6 mm

Technical data

Electrical data	Nominal voltage	AC/DC 24 V			
	Nominal voltage range	AC 21.6...26.4 V / DC 13.5...26.4 V			
	Power consumption AC	0.8 VA			
	Power consumption DC	0.4 W			
	Electrical connection	Pluggable spring loaded terminal block max. 2.5 mm ²			
	Cable entry	Cable gland with strain relief ø6...8 mm			
Functional data	Sensor technology	Based on Pt1000 1/3 DIN			
	Application	Air Water			
	Multirange	8 measuring ranges selectable			
	Voltage output	1 x 0...5 V, 0...10 V, min. resistance 5 kΩ			
	Output signal active note	Output 0...5/10 V with Jumper adjustable			
Measuring data	Measured values	Temperature			
Specification Temperature	Measuring range temperature settings	Active sensor: range selectable Attention: max. measuring temperature is restricted by max. fluid temperature (see Safety data)			
		Setting	Range [°C]	Range [°F]	Factory setting
		S0	-50...50	-30...130	
		S1	-10...120	0...250	
		S2	0...50	40...140	
		S3	0...250	30...480	
		S4	-15...35	0...100	
		S5	0...100	40...240	
		S6	-20...80	40...90	
		S7	0...160	0...150	✓

Technical data

Specification Temperature	Accuracy temperature active	±0.5°C @ 21°C [±0.9°F @ 70°F] @ measuring range setting S2 and S4
	Long term stability	±0.04°C p.a. @ 21°C [±0.07°F p.a. @ 70°F]
	Time constant τ (63%) in water pipe	Typical 7 s with thermowell brass Typical 9 s with thermowell stainless steel
	Time constant τ (63%) in the air duct	Typical 46 s @ 3 m/s Typical 210 s @ 0 m/s
Safety data	Protection class IEC/EN	III, Protective Extra-Low Voltage (PELV)
	Power source UL	Class 2 Supply
	Degree of protection IEC/EN	IP65
	Degree of protection NEMA/UL	NEMA 4X
	Enclosure	UL Enclosure Type 4X
	EU Conformity	CE Marking
	Certification IEC/EN	IEC/EN 60730-1
	Quality Standard	ISO 9001
	UL Approval	cULus acc. to UL60730-1A/-2-9, CAN/CSA E60730-1/-2-9
	Type of action	Type 1
	Rated impulse voltage supply	0.8 kV
	Pollution degree	3
	Ambient humidity	Max. 95% RH, non-condensing
	Ambient temperature	-35...50°C [-30...122°F]
Fluid temperature	-50...160°C [-60...320°F]	
Housing surface temperature	Max. 70°C [160°F]	
Materials	Cable gland	PA6, black
	Housing	Cover: PC, orange Bottom: PC, orange Seal: NBR70, black UV resistant
	Probe material	V4A (1.4404)

Safety notes

This device has been designed for use in stationary heating, ventilation and air-conditioning systems and must not be used outside the specified field of application. Unauthorised modifications are prohibited. The product must not be used in relation with any equipment that in case of a failure may threaten humans, animals or assets.

Ensure all power is disconnected before installing. Do not connect to live/operating equipment.

Only authorised specialists may carry out installation. All applicable legal or institutional installation regulations must be complied with during installation.

The device contains electrical and electronic components and must not be disposed of as household refuse. All locally valid regulations and requirements must be observed.

Remarks

General remarks concerning sensors When using lengthy connection wires (depending on the cross section used) the measuring result might be falsified due to a voltage drop at the common GND-wire (caused by the voltage current and the line resistance). In this case, 2 GND-wires must be wired to the sensor - one for supply voltage and one for the measuring current.

Sensing devices with a transducer should always be operated in the middle of the measuring range to avoid deviations at the measuring end points. The ambient temperature of transducer electronics should be kept constant. The transducers must be operated at a constant supply voltage (± 0.2 V). When switching the supply voltage on/off, onsite power surges must be avoided.

Remark: Occurring draft leads to a better carrying-off of dissipative power at the sensor. Thus temporally limited fluctuations might occur upon temperature measurement.

Build-up of self-heating by electrical dissipative power Temperature sensors with electronic components always have a dissipative power which affects the temperature measurement of the ambient air. The dissipation in active temperature sensors shows a linear increase with rising operating voltage. The dissipative power should be taken into account when measuring temperature.

In case of a fixed operating voltage (± 0.2 V), this is normally done by adding or reducing a constant offset value. As Belimo transducers work with a variable operating voltage, for reasons of production engineering only one operating voltage can be taken into consideration. Transducers 0...10 V / 4...20 mA have a standard setting at an operating voltage of DC 24 V. This means that at this voltage, the expected measuring error of the output signal will be the least. For other operating voltages, the offset error will be increased by a changing power loss of the sensor electronics.

If a readjustment directly at the active sensor should be necessary during later operation, this can be done with the following adjustment methods.

- For sensors with NFC or dongle with the corresponding Belimo app
- For sensors with a trimming potentiometer on the sensor board
- For bus sensors via bus interface with a corresponding software variable

Parts included

Description	Type
Mounting clip, with screws and adhesive foil	A-22D-A11

Accessories

Optional accessories	Description	Type
	Mounting plate S housing	A-22D-A09
	Connection adapter flex conduit, M20x1.5, for cable gland 1x 6 mm, Multipack 10 pcs.	A-22G-A01.1

Optional accessories air	Description	Type
	Mounting flange for sensor probe 6 mm, up to max. 120°C [248°F], Plastic	A-22D-A03
	Mounting flange for sensor probe 6 mm, up to max. 260°C, Brass	A-22D-A05

Recommended accessories water	Description	Type
	Thermowell Stainless steel, 50 mm, G 1/2", SW27	A-22P-A06
	Thermowell Brass, 50 mm, R 1/2", SW22	A-22P-A18
	Syringe with thermal paste	A-22P-A44
	Compression fitting, Stainless steel, G 1/4" (external thread) for 6 mm, with cutting ring	A-22P-A45
	Thermowell Stainless steel, 100 mm, G 1/2", SW27	A-22P-A08
	Thermowell Brass, 100 mm, R 1/2", SW22	A-22P-A20
	Cold barrier, Plastic, L 50 mm, for thermowell A-22P-A..	A-22P-A51
	Thermowell Stainless steel, 150 mm, G 1/2", SW27	A-22P-A10

Accessories

Description	Type
Thermowell Brass, 150 mm, R 1/2", SW22	A-22P-A22
Thermowell Stainless steel, 200 mm, G 1/2", SW27	A-22P-A12
Thermowell Brass, 200 mm, R 1/2", SW22	A-22P-A24
Thermowell Stainless steel, 300 mm, G 1/2", SW27	A-22P-A14
Thermowell Brass, 300 mm, R 1/2", SW22	A-22P-A26
Thermowell Stainless steel, 250 mm, G 1/2", SW27	A-22P-A29
Thermowell Brass, 250 mm, R 1/2", SW22	A-22P-A30
Thermowell Stainless steel, 450 mm, G 1/2", SW27	A-22P-A16
Thermowell Brass, 450 mm, R 1/2", SW22	A-22P-A28

Wiring diagram

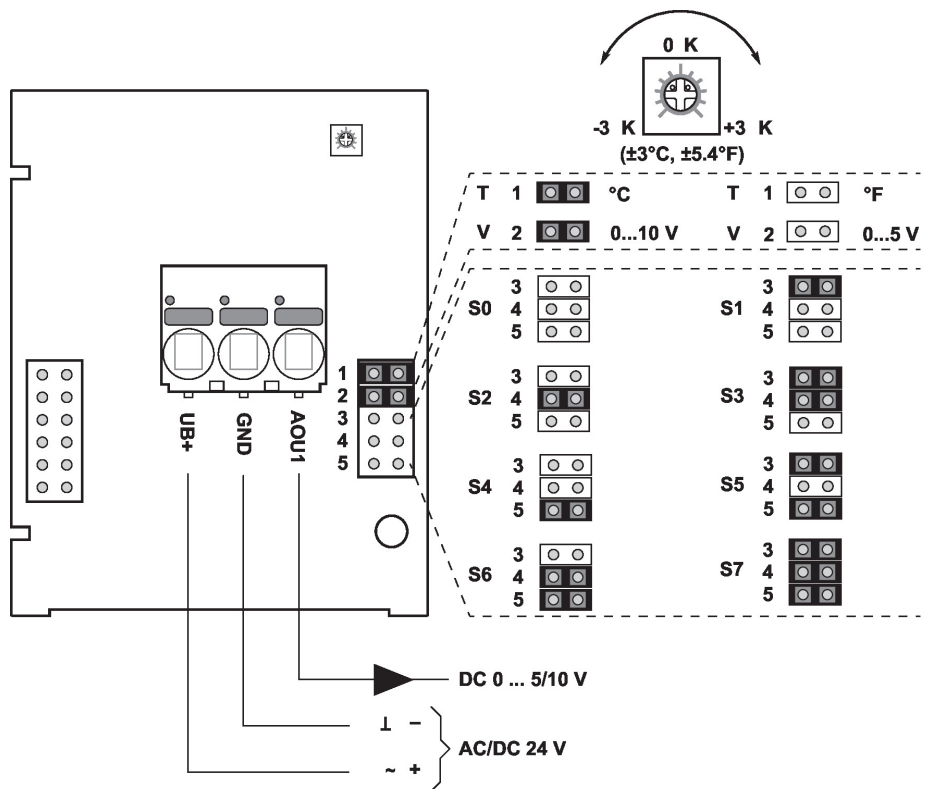

The adjustment of the measuring ranges is made by changing the bonding jumpers. The output value in the new measuring range is available after 2 seconds.

Setting	Range [°C]	Range [°F]	Factory setting
S0	-50...50	-30...130	
S1	-10...120	0...250	
S2	0...50	40...140	
S3	0...250	30...480	
S4	-15...35	0...100	
S5	0...100	40...240	
S6	-20...80	40...90	
S7	0...160	0...150	✓

Dimensions

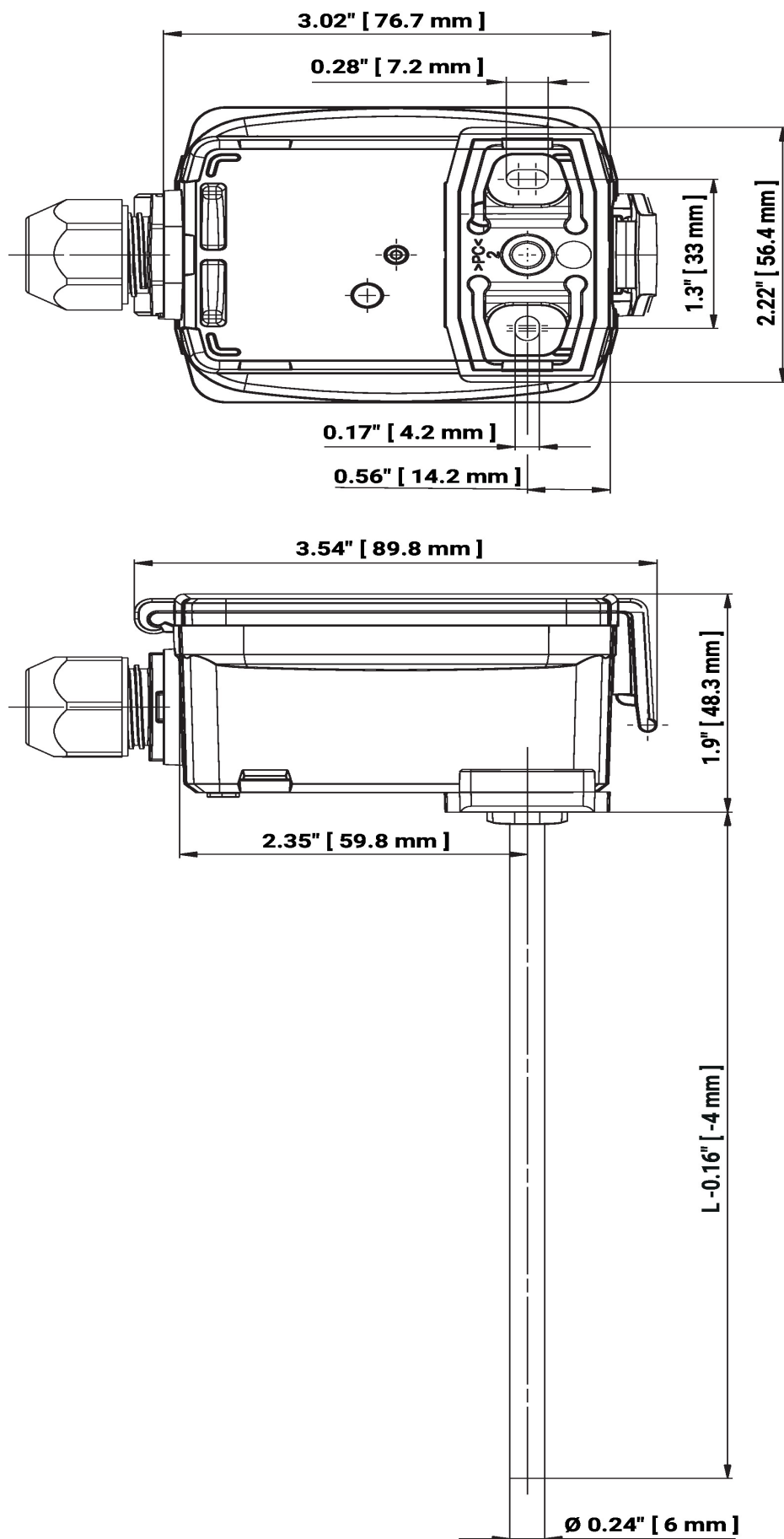

Dimensions

L = Probe length

Type	Probe length	Weight
22DT-12H	50 mm	0.12 kg
22DT-12L	100 mm	0.13 kg
22DT-12N	150 mm	0.13 kg
22DT-12P	200 mm	0.14 kg
22DT-12R	300 mm	0.15 kg
22DT-12T	450 mm	0.16 kg

Further documentation

- Installation instructions
- Sensor length calculator