

Communicative damper actuator for adjusting dampers in technical building installations

- Air damper size up to approx. 0.4 m<sup>2</sup>
- Torque motor 2 Nm
- Nominal voltage AC/DC 24 V
- Control communicative
- Communication via Belimo MP-Bus



Picture may differ from product

## Technical data

<b>Electrical data</b>	Nominal voltage	AC/DC 24 V
	Nominal voltage frequency	50/60 Hz
	Nominal voltage range	AC 19.2...28.8 V / DC 19.2...28.8 V
	Power consumption in operation	1 W
	Power consumption in rest position	0.5 W
	Power consumption for wire sizing	1.5 VA
	Connection supply / control	Cable 1 m, 3x 0.75 mm <sup>2</sup>
	Parallel operation	Yes (note the performance data)
<b>Data bus communication</b>	Communicative control	MP-Bus
	Number of nodes	MP-Bus max. 8 (16)
<b>Functional data</b>	Torque motor	2 Nm
	Position feedback U note	Max. 1 mA
	Position accuracy	±5%
	Direction of motion motor	clockwise rotation (cw)
	Direction of motion note	0%: right end stop, position 0
	Manual override	with magnet
	Angle of rotation	0...287.5°
	Running time motor	75 s / 90°
	Sound power level, motor	35 dB(A)
	Adaptation setting range	manual with magnet (automatic on first power-up)
	Mechanical interface	Universal shaft clamp 6...12.7 mm
	Position indication	Mechanical, pluggable (with integrated magnet for gear train disengagement)
<b>Safety data</b>	Protection class IEC/EN	III, Safety Extra-Low Voltage (SELV)
	Power source UL	Class 2 Supply
	Degree of protection IEC/EN	IP54
	Degree of protection NEMA/UL	NEMA 2
	Housing	UL Enclosure Type 2
	EMC	CE according to 2014/30/EU
	Certification IEC/EN	IEC/EN 60730-1 and IEC/EN 60730-2-14
	UL Approval	cULus according to UL60730-1A, UL60730-2-14 and CAN/CSA E60730-1 The UL marking on the actuator depends on the production site, the device is UL-compliant in any case
	Hygiene test	According to VDI 6022 Part 1
	Type of action	Type 1
	Rated impulse voltage supply / control	0.8 kV
Pollution degree	3	

**Technical data**

<b>Safety data</b>	Ambient humidity	Max. 95% RH, non-condensing
	Ambient temperature	-30...50°C [-22...122°F]
	Storage temperature	-40...80°C [-40...176°F]
	Servicing	maintenance-free
<b>Weight</b>	Weight	0.24 kg

**Safety notes**

- This device has been designed for use in stationary heating, ventilation and air-conditioning systems and must not be used outside the specified field of application, especially in aircraft or in any other airborne means of transport.
- Outdoor application: Only possible if no (sea) water, snow, ice, sunlight or aggressive gases act directly on the device and if it is ensured that the ambient conditions remain within the limit values specified in the data sheet at all times.
- Only authorised specialists may carry out installation. All applicable legal or institutional installation regulations must be complied with during installation.
- The device may only be opened at the manufacturer's site. It does not contain any parts that can be replaced or repaired by the user.
- Cables must not be removed from the device.
- The device contains electrical and electronic components and must not be disposed of as household refuse. All locally valid regulations and requirements must be observed.

**Product features**

**Operating mode** The actuator receives its digital control signal from the higher level controller via the MP-Bus and drives to the position defined. Connection U serves as communication interface and does not supply an analogue measuring voltage.  
 Note: Neither a conventional operation with a standard signal nor a configuration of signals (e.g. running time) is possible. With the configuration devices, a functional check can be executed and the MP adress can be assigned.

**Configurable device** The factory settings cover the most common applications. Single parameters can be modified with Belimo Assistant 2.

**Simple direct mounting** The actuator is mounted directly on the damper shaft (ø6...12.7 mm) with a universal shaft clamp and then secured with the anti-rotation clip, to prevent it from rotating.  
 The anti-rotation clip Z-ARCM is included in the scope of delivery.

**Manual override** Manual override with magnet possible (the gear train is disengaged as long as the magnet adheres to the magnet symbol). The magnet for gear train disengagement is integrated in the position indicator.  
 After a manual override, it is mandatory that an adaptation via magnet be triggered at the position intended for this purpose.

**Adjustable angle of rotation** Adjustable angle of rotation with mechanical end stops.

**High functional reliability** The actuator is overload protected, requires no limit switches and automatically stops when the end stop is reached.

**Home position** The first time the supply voltage is switched on, i.e. at the time of commissioning, the actuator carries out an adaptation, which is when the operating range and position feedback adjust themselves to the mechanical setting range.  
 The actuator then moves into the position defined by the control signal.



**Adaptation and synchronisation** An adaptation can be triggered manually through activation of the magnet switch or with the PC-Tool. Both mechanical end stops are detected during the adaptation (entire setting range).  
 The actuator then moves into the position defined by the control signal.

**Product features**

**Hidden synchronisation** If the actuator drives to the lower end stop during ongoing operation, then it performs a synchronisation.

**Accessories**

	Tools	Description	Type
		Service tool for wired and wireless setup, on-site operation and troubleshooting.	Belimo Assistant 2
		Belimo Assistant Link Bluetooth and USB to NFC and MP-Bus converter for configurable and communicative devices	LINK.10
		Connecting cable 5 m, A: RJ11 6/4 LINK.10, B: 6-pin for connection to service socket	ZK1-GEN
		Connecting cable 5 m, A: RJ11 6/4 LINK.10, B: free wire end for connection to MP/PP terminal	ZK2-GEN
Electrical accessories	Description	Description	Type
		MP-Bus power supply for MP actuators	ZN230-24MP
Gateways	Description	Description	Type
		Gateway MP to BACnet MS/TP	UK24BAC
		Gateway MP to Modbus RTU	UK24MOD

**Electrical installation**

**Supply from isolating transformer.**  
**Parallel connection of other actuators possible. Observe the performance data.**

**Wire colours:**

- 1 = black
- 2 = red
- 5 = orange

AC/DC 24 V, MPL

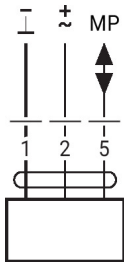
**Further electrical installations**
**MP-Bus**

MP-Bus Network topology

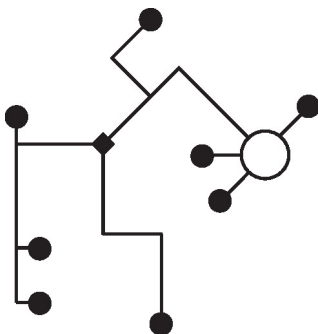

There are no restrictions for the network topology (star, ring, tree or mixed forms are permitted). Supply and communication in one and the same 3-wire cable

- no shielding or twisting necessary
- no terminating resistors required

Connection on the MP-Bus

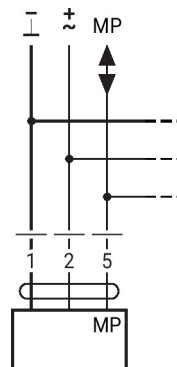

Max. 8 (16) additional actuators

Operating controls and indicators

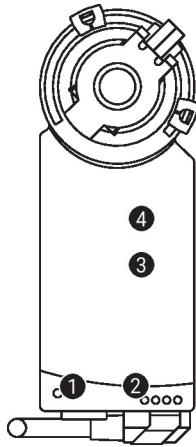

**1 LED display yellow**

On: Angle of rotation adaptation active

**2 LED display green**

Off: No power supply or no MP-Bus level

On: Power supply and MP-Bus level OK

Flickering: MP-Bus communication active

Flashing: Depiction of MP address (Command from MP client)

**3 Magnet switch**

Magnetised: Triggering the angle of rotation adaptation

**4 Magnet disengagement**

Magnetised: Gear train disengages, manual override possible

Service

Using Belimo Assistant 2, device parameters can be modified. Belimo Assistant 2 can operate on a smartphone, tablet or PC. The available connection options vary depending on the hardware on which Belimo Assistant 2 is installed.

For more information about Belimo Assistant 2, refer to the Quick Guide – Belimo Assistant 2.



**Wired connection**

Belimo devices can be accessed by connecting Belimo Assistant Link to the USB port on a PC or laptop and to the Service Socket or MP-Bus wire on the device.

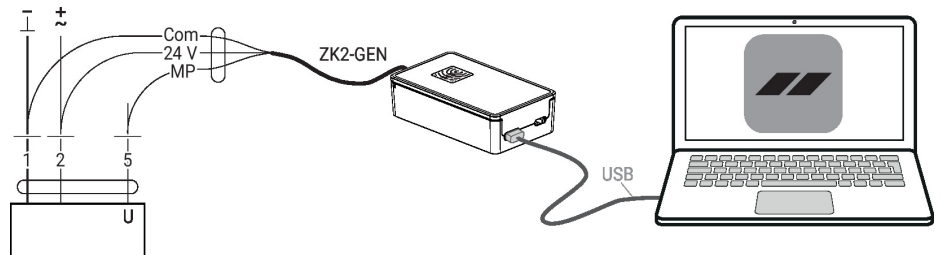

## Dimensions

## Shaft length

	Min. 32
--	---------

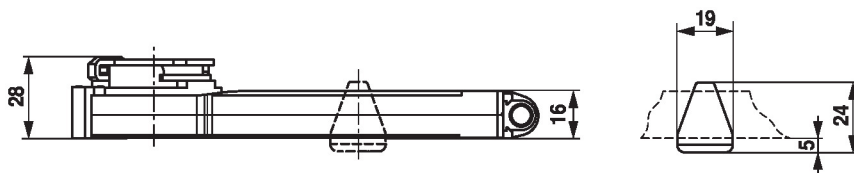

## Clamping range

6...12.7	6 / 8 / 10	6...12.7

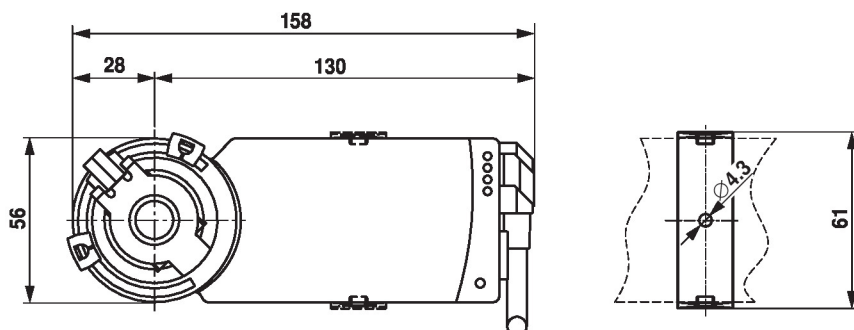

## Further documentation

- Overview MP Cooperation Partners
- Tool connections
- Introduction to MP-Bus Technology
- Quick Guide – Belimo Assistant 2

## Application notes

- For digital control of actuators in VAV applications patent EP 3163399 must be considered.