

- Nominal voltage AC/DC 24 V
- Control modulating, communicative, hybrid, Cloud

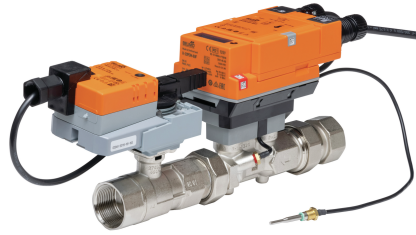

Structure

Components The Belimo Energy Valve MID consists of a characterised control valve, an actuator and a thermal energy meter with a logic and a sensor module.

The logic module provides the power supply, the communication interface and the NFC connection of the energy meter. All MID-relevant data are measured and recorded in the sensor module. The display is also located in the sensor module.

This modular design of the energy meter means that the logic module can remain in the system if the sensor module is replaced.

- External temperature sensor T1
- Integrated temperature sensor T2
- Logic module 1
- Sensor module 2
- Characterised control valve with actuator 3

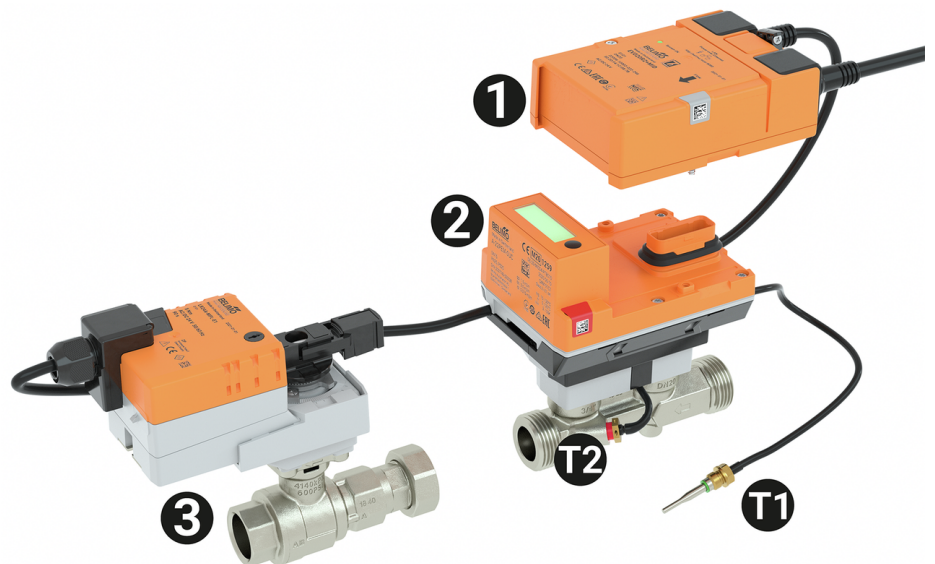

Technical data

Electrical data		
Nominal voltage	AC/DC 24 V	
Nominal voltage frequency	50/60 Hz	
Nominal voltage range	AC 19.2...28.8 V / DC 21.6...28.8 V	
Power consumption in operation	4 W	
Power consumption for wire sizing	7 VA	
Connection Ethernet	RJ45 socket	
Power over Ethernet PoE	DC 37...57 V 11 W (PD13W) IEEE 802.3af/at, Type 1, Class 3	

Electrical data	Conductors, cables	AC/DC 24 V, cable length <100 m, no shielding or twisting required Shielded cables are recommended for supply via PoE
	Battery operation	Battery buffering for 14 months in battery operation only For battery operation - Continuity of energy metering - Storage of the cumulated meter readings - no communication (except NFC) - Display function
	Switching to battery operation	When the supply voltage of AC/DC 24 V or PoE is interrupted
Data bus communication	Communicative control	BACnet/IP, BACnet MS/TP Modbus TCP, Modbus RTU MP-Bus Cloud
Functional data	Valve size [mm]	1" [25]
	Operating range Y	2...10 V
	Operating range Y note	4...20 mA w/ ZG-R01 (500 Ω, 1/4 W resistor)
	Input impedance	100 kΩ (0.1 mA), 500 Ω
	Operating modes optional	VDC variable
	Position feedback U	2...10 V
	Position feedback U variable	VDC variable
	Running time motor	90 s
	Control accuracy	±5%
	Min. controllable flow	1% of V ^{nom}
	Fluid temperature	-10...120°C [14...250°F]
	Close-off pressure Δps	200 psi
	Body Pressure Rating	360 psi
	GPM	15.4
	Pipe connection	Internal thread NPT (female)
	Servicing	maintenance-free
Manual override	external push button	
Measuring data	Measured values	Flow Temperature
	Temperature sensor	Pt1000 - EN 60751, 2-wire technology, inseparably connected Cable length external sensor T1: 3 m
Heat meter	Registration	DE-21-MI004-PTB010 Fluid temperature flow sensor: 15...120°C Temperature range temperature sensors: 0...120°C Difference range: 3...100 K
	Classification	Accuracy class 2 / environment class A Mechanical environment: Class M1 Electromagnetic environment: Class E1
Temperature measurement	Measuring accuracy temperature difference	±0.18 K @ ΔT = 10 K ±0.23 K @ ΔT = 20 K

Technical data

Temperature measurement	Resolution	0.05°C
	Flow measurement	Measuring accuracy flow
	Measurement repeatability	±0.5% (Flow)
	Sensor technology	Ultrasonic with glycol and temperature compensation
Safety data	Power source UL	Class 2 Supply
	Degree of protection IEC/EN	IP54 IP54 when using protective cap or protective grommet for RJ45 socket. Sensor module: IP65
	Degree of protection NEMA/UL	NEMA 1
	Enclosure	UL Enclosure Type 1
	Quality Standard	ISO 9001
	UL 2043 Compliant	Suitable for use in air plenums per Section 300.22(C) of the NEC and Section 602 of the IMC
	Ambient humidity	Max. 95% RH, non-condensing
	Ambient temperature	-30...50°C [-22...122°F]
	Storage temperature	-40...80°C [-40...176°F]
	Materials	Valve body
Flow measuring pipe		Brass body nickel-plated
Spindle		Stainless steel
Spindle seal		EPDM (lubricated)
Seat		PTFE
Characterised disc		TEFZEL®
O-ring		EPDM
Ball		Stainless steel

Safety notes

- This device has been designed for use in stationary heating, ventilation and air-conditioning systems and must not be used outside the specified field of application, especially in aircraft or in any other airborne means of transport.
- Outdoor application: only possible in case that no (sea) water, snow, ice, insolation or aggressive gases interfere directly with the device and that it is ensured that the ambient conditions remain within the thresholds according to the data sheet at any time.
- Only authorised specialists may carry out installation. All applicable legal or institutional installation regulations must be complied with during installation.
- The device contains electrical and electronic components and must not be disposed of as household refuse. All locally valid regulations and requirements must be observed.

Product features

Operating mode The HVAC performance device is comprised of four components: characterised control valve (CCV), measuring pipe with flow sensor, temperature sensors and the actuator itself. The adjusted maximum flow ($V'max$) is assigned to the maximum control signal DDC (typically 10 V / 100%). Alternatively, the control signal DDC can be assigned to the valve opening angle or to the power required on the heat exchanger (see power control). The HVAC performance device can be controlled via communicative or analogue signals. The fluid is detected by the sensor in the measuring pipe and is applied as the flow value. The measured value is balanced with the setpoint. The actuator corrects the deviation by changing the valve position. The angle of rotation α varies according to the differential pressure through the control element (see flow curves).

Accessories

Replacement sensor modules	Description	Type
	T-piece with thermowell DN 1/2" [15]	A-22PE-A09
	T-piece with thermowell DN 3/4" [20]	A-22PE-A10
	T-piece with thermowell DN 1" [25]	A-22PE-A11
	T-piece with thermowell DN 1 1/4" [32]	A-22PE-A12
	T-piece with thermowell DN 1 1/2" [40]	A-22PE-A13
	T-piece with thermowell DN 2" [50]	A-22PE-A14
Tools	Description	Type
	Converter Bluetooth / NFC	ZIP-BT-NFC
Sensors	Description	Type
	Differential pressure sensor Water, 0...15 psi, active, 0...10 V	22WDP-511
	Differential pressure sensor Water, 0...30 psi, active, 0...10 V	22WDP-512
	Differential pressure sensor Water, 0...50 psi, active, 0...10 V	22WDP-514
	Differential pressure sensor Water, 0...100 psi, active, 0...10 V	22WDP-515

Electrical installation



Supply from isolating transformer.
 Parallel connection of other actuators possible. Observe the performance data.
 The wiring of the line for BACnet MS/TP / Modbus RTU is to be carried out in accordance with applicable RS-485 regulations.
 Modbus / BACnet: Supply and communication are not galvanically isolated. Connect earth signal of the devices with one another.
 Sensor connection: An additional sensor can optionally be connected to the thermal energy meter. This can be a passive resistance sensor Pt1000, Ni1000, NTC10k (10k2), an active sensor with output DC 0...10 V or a switching contact. Thus the analogue signal of the sensor can be easily digitised with the thermal energy meter and transferred to the corresponding bus system.
 Analogue output: An analogue output (wire 5) is available on the thermal energy meter. It can be selected as DC 0...10 V, DC 0.5...10 V or DC 2...10 V. For example, the flow rate or the temperature of the temperature sensor T1/T2 can be output as an analogue value.

Wire colours:

- 1 = black
- 2 = red
- 3 = white
- 5 = orange
- 6 = pink
- 7 = grey

Functions:

- 1 = Com
- 2 = AC/DC 24 V
- 3 = Sensor (optional)
- 5 = 0...10 V, MP-Bus
- C1 = D- = A (wire 6)
- C2 = D+ = B (wire 7)

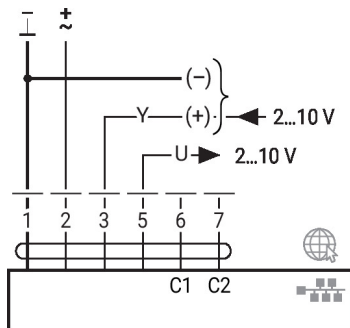

Electrical installation

BACnet MS/TP / Modbus RTU

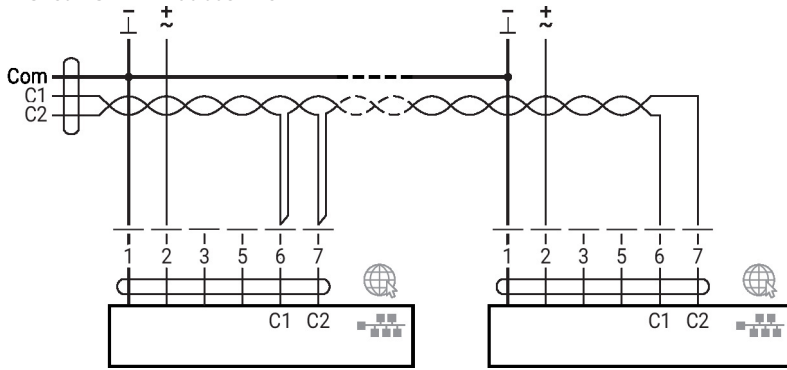

BACnet/IP / Modbus TCP

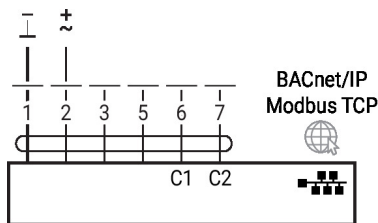

MP-Bus, supply via 3-wire connection

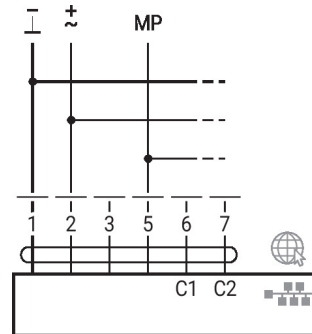

PoE with BACnet/IP / Modbus TCP

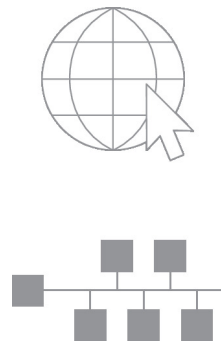
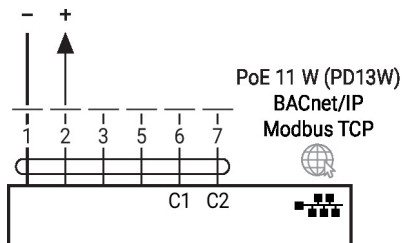

Connection of a notebook for parametrisation and manual control via RJ45.

Optional connection via RJ45 (direct connection to notebook / connection via Intranet or Internet) for access to the integrated web server

Connection with passive sensor

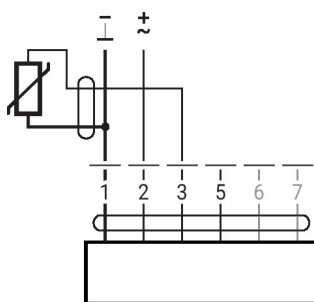

Connection with switching contact

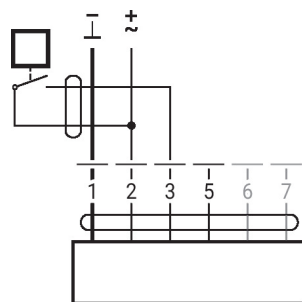

Connection with active sensor

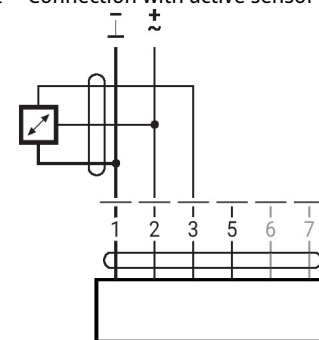

Functions

Functions with specific parameters (parametrisation necessary)

Override control and limiting with AC 24 V with relay contacts

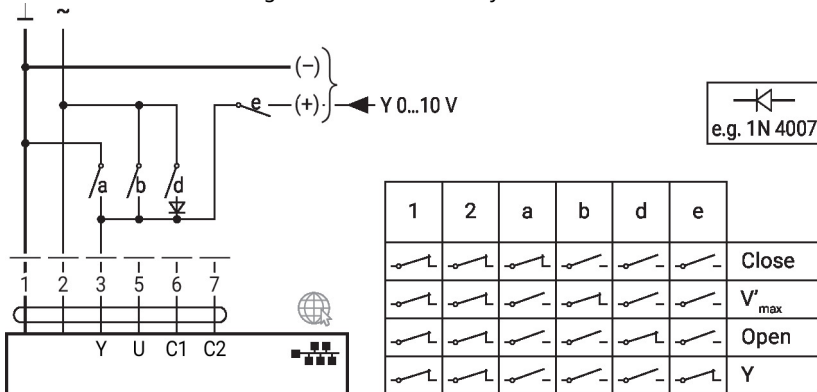

Override control and limiting with DC 24 V with relay contacts (with conventional control or hybrid mode)

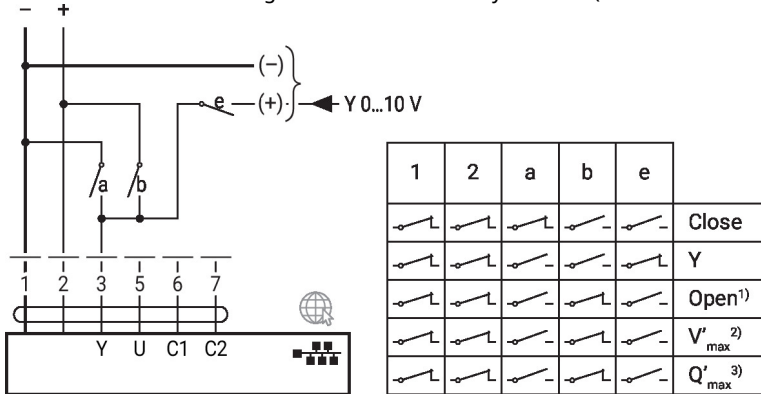

- 1) Position control
- 2) Flow control
- 3) Power control

Override control and limiting with DC 24 V with relay contacts (with conventional control or hybrid mode)

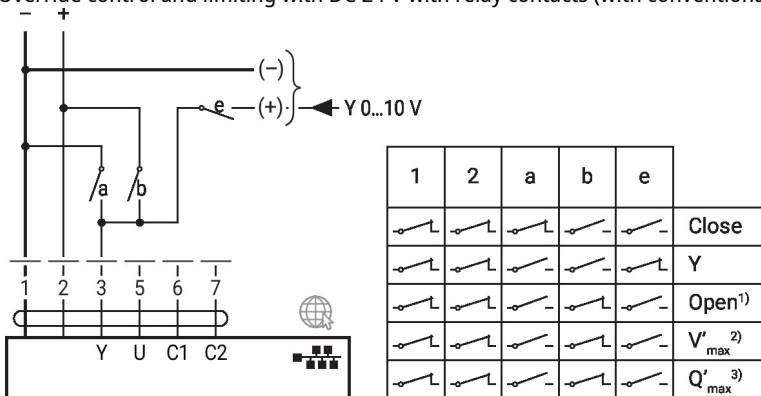

- 1) Position control
- 2) Flow control
- 3) Power control

MP-Bus, supply via 3-wire connection

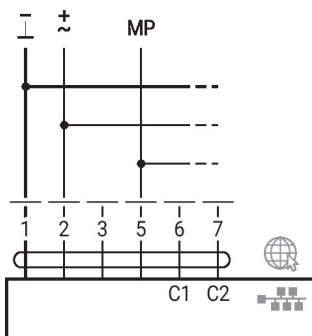

MP-Bus via 2-wire connection, local power supply

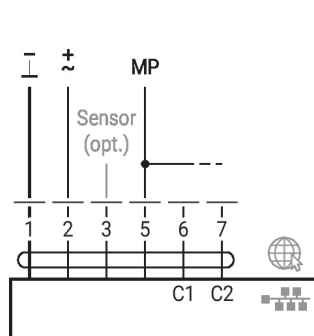

M-Bus with converter

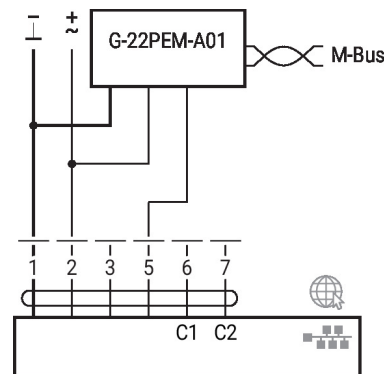

Functions

Functions with specific parameters (parametrisation necessary)

M-Bus with converter in parallel mode with PoE with BACnet/IP / Modbus TCP



M-Bus with converter in parallel mode with BACnet/IP / Modbus TCP

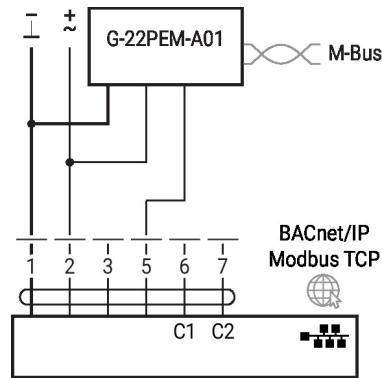

Installation notes

Permissible installation orientation The ball valve can be installed upright to horizontal. The ball valve may not be installed in a hanging position, i.e. with the spindle pointing downwards.

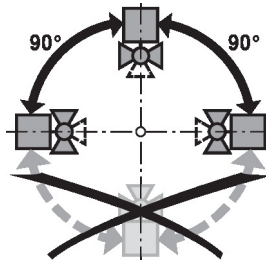

Installation location in return Installation in the return is recommended.

Water quality requirements The water quality requirements specified in VDI 2035 must be adhered to. Belimo valves are regulating devices. For the valves to function correctly in the long term, they must be kept free from particle debris (e.g. welding beads during installation work). The installation of a suitable strainer is recommended.

Servicing Ball valves, rotary actuators and sensors are maintenance-free. Before any service work on the control element is carried out, it is essential to isolate the rotary actuator from the power supply (by unplugging the electrical cable if necessary). Any pumps in the part of the piping system concerned must also be switched off and the appropriate slide valves closed (allow all components to cool down first if necessary and always reduce the system pressure to ambient pressure level). The system must not be returned to service until the ball valve and the rotary actuator have been correctly reassembled in accordance with the instructions and the pipeline has been refilled by professionally trained personnel.

Flow direction The direction of flow, specified by an arrow on the housing, is to be complied with, since otherwise the flow rate will be measured incorrectly.

Cleaning of pipes Before installing the thermal energy meter, the circuit must be thoroughly rinsed to remove impurities.

Prevention of stresses The thermal energy meter must not be subjected to excessive stress caused by pipes or fittings.

Installation notes

Inlet section In order to achieve the specified measuring accuracy, a flow-calming section or inflow section in the direction of the flow is to be provided upstream from the flow sensor. Its dimensions should be at least 5x DN.

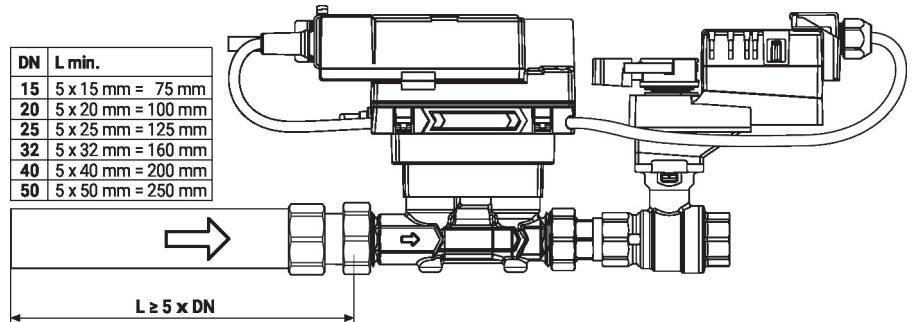

Dimensions

Dimensional drawings

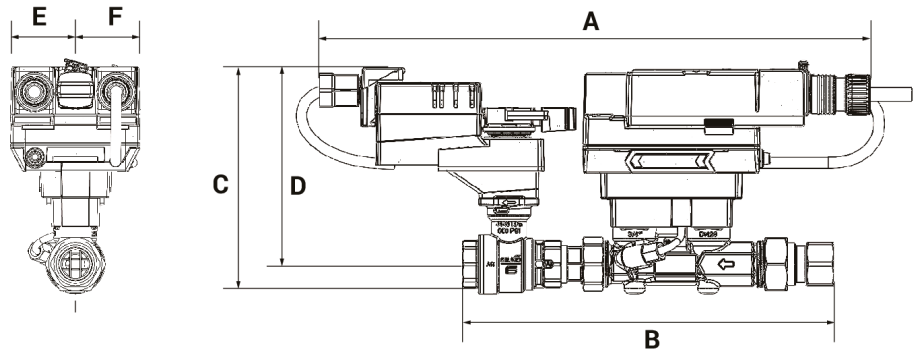

A	B	C	D	E	F
15.5" [394]	11.1" [282]	163	5.5" [140]	1.8" [46]	46