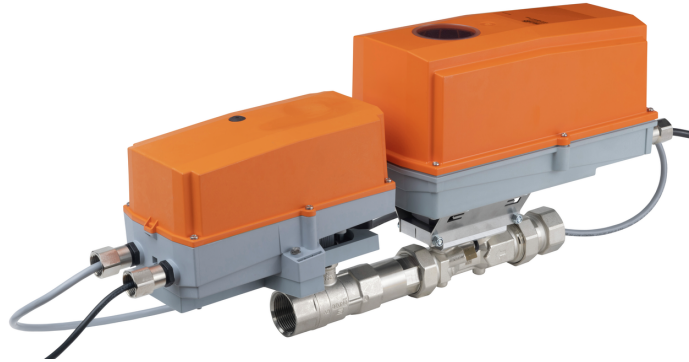

Pressure-independent characterised control valve, 2-way, Internal thread, (EPIV

SRK..A)

- Nominal voltage AC/DC 24 V
- Control modulating, communicative, hybrid
- For modulating control of air-handling and heating systems on the water side
- Communication via BACnet MS/TP, Modbus RTU, Belimo-MP-Bus or conventional control
- Conversion of active sensor signals and switching contacts

**Technical data**

<b>Electrical data</b>	Nominal voltage	AC/DC 24 V
	Nominal voltage frequency	50/60 Hz
	Nominal voltage range	AC 19.2...28.8 V / DC 21.6...28.8 V
	Power consumption in operation	35W incl. heater
	Power consumption for wire sizing	44 VA incl. heater
	Connection supply / control	cable 3 ft. [1 m], 6 x 0.75 mm <sup>2</sup>
	Conductors, cables	AC/DC 24 V, cable length <100 m
<b>Data bus communication</b>	Communicative control	BACnet MS/TP Modbus RTU MP-Bus
	<b>Functional data</b>	
	Valve size [mm]	2" [50]
Operating range Y	2...10 V	
Operating range Y note	4...20 mA w/ ZG-R01 (500 Ω, 1/4 W resistor)	
Input impedance	100 kΩ (0.1 mA), 500 Ω	
Operating range Y variable	0.5...10 V	
Operating modes optional	VDC variable	
Position feedback U	2...10 V	
Position feedback U note	Max. 1 mA	
Position feedback U variable	VDC variable	
Setting fail-safe position	NC/NO or adjustable 0...100% (POP rotary knob)	
Bridging time (PF) variable	0...10 s	
Running time motor	90 s	
Running time fail-safe	<35 s	
Sound power level Motor	45 dB(A)	
Sound power level, fail-safe	61 dB(A)	
V'max adjustable	25...100% of V'nom	
Control accuracy	±5%	
Min. controllable flow	1% of V'nom	
Parametrisation	via NFC, Belimo Assistant App	
Fluid temperature	-10...120°C [14...250°F]	
Close-off pressure Δps	200 psi	
Body Pressure Rating	360 psi	
Leakage rate	0% leakage	
GPM	100	
Pipe connection	Internal thread NPT (female)	

**Technical data**

<b>Functional data</b>	Installation orientation	upright to horizontal (in relation to the stem)
	Servicing	maintenance-free
	Manual override	external push button
<b>Thermostat / Humidistat</b>	Type of contact	Normally closed contact
	Heating output	21 W
	Switch-on current	Max. 2.5 A
	Settings	65% RH fixed
	Heater	Aluminium profile, anodised
	Sensor element	Thermobimetal
<b>Measuring data</b>	Measured values	Flow
	Temperature sensor	Pt1000 - EN 60751, 2-wire technology, inseparably connected integrated in flow sensor
<b>Temperature measurement</b>	Measuring accuracy absolute temperature	± 0.35°C @ 10°C (Pt1000 EN60751 Class B) ± 0.6°C @ 60°C (Pt1000 EN60751 Class B)
<b>Flow measurement</b>	Measuring principle	Ultrasonic volumetric flow measurement
	Min. flow measurement	0.5% of V'nom
	Measurement repeatability	±0.5% (Flow)
	Sensor technology	Ultrasonic with glycol and temperature compensation
<b>Safety data</b>	Degree of protection IEC/EN	IP66
	Degree of protection NEMA/UL	NEMA 4
	Enclosure	UL Enclosure Type 4
	Pressure equipment directive	CE according to 2014/68/EU
	Quality Standard	ISO 9001
	UL 2043 Compliant	Suitable for use in air plenums per Section 300.22(C) of the NEC and Section 602 of the IMC
	Rated impulse voltage supply / control	0.8 kV
	Ambient humidity	Max. 100% RH
	Ambient temperature	-30...50°C [-22...122°F]
	Storage temperature	-40...80°C [-40...176°F]
<b>Materials</b>	Valve body	Nickel-plated brass body
	Flow measuring pipe	Brass body nickel-plated
	Closing element	Stainless steel
	Spindle	Stainless steel
	Spindle seal	EPDM (lubricated)
	Seat	PTFE
	Characterised disc	TEFZEL®
	O-ring	EPDM
	Ball	Stainless steel
<b>Terms</b>	Abbreviations	POP = Power off position / fail-safe position PF = Power fail delay time / bridging time

## Safety notes



- This device has been designed for use in stationary heating, ventilation and air-conditioning systems and must not be used outside the specified field of application, especially in aircraft or in any other airborne means of transport.
- Outdoor application: only possible in case that no (sea) water, snow, ice, insolation or aggressive gases interfere directly with the device and that it is ensured that the ambient conditions remain within the thresholds according to the data sheet at any time.
- Only authorised specialists may carry out installation. All applicable legal or institutional installation regulations must be complied with during installation.
- The device contains electrical and electronic components and must not be disposed of as household refuse. All locally valid regulations and requirements must be observed.

## Product features

**Operating mode** The HVAC performance device is comprised of three components: characterised control valve (CCV), measuring pipe with flow sensor and the actuator itself. The adjusted maximum flow ( $V'max$ ) is assigned to the maximum control signal (typically 100%). The HVAC performance device can be controlled via communicative signals. The fluid is detected by the sensor in the measuring pipe and is applied as the flow value. The measured value is balanced with the setpoint. The actuator corrects the deviation by changing the valve position. The angle of rotation  $\alpha$  varies according to the differential pressure through the control element (see flow curves).

With the supply voltage the integrated condensers will be charged.

Interrupting the supply voltage causes the valve to be moved to the selected fail-safe position by means of stored electrical energy.

## Flow rate curves

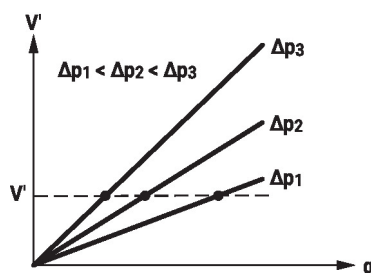

**Pre-charging time (start up)**

The capacitor actuators require a pre-charging time. This time is used for charging the capacitors up to a usable voltage level. This ensures that, in the event of a power failure, the actuator can move at any time from its current position into the preset fail-safe position.

The duration of the pre-charging time depends mainly on following factors:

- Duration of the power failure
- PF delay time (bridging time)

Typical pre-charging time

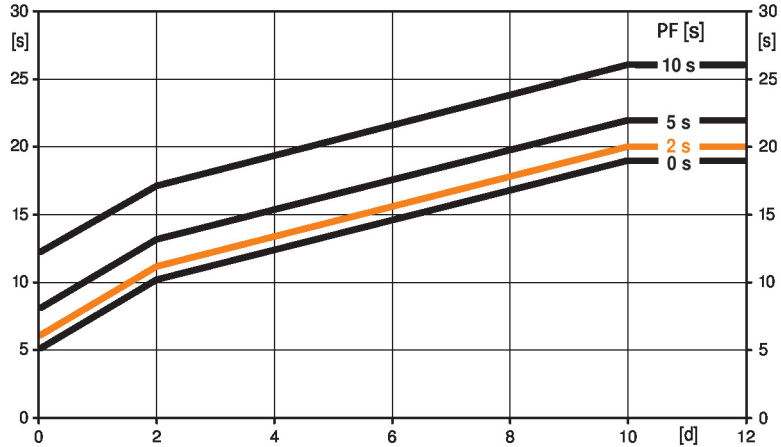

[d] = Power failure in days  
 [s] = Pre-charging time in seconds  
 PF[s] = Bridging time  
 Calculation example: Given a power failure of 3 days and a bridging time (PF) set at 5 s, the actuator requires a pre-charging time of 14 s after the power has been reconnected (see graphic).

PF [s]	[d]				
	0	1	2	7	≥10
0	5	8	10	15	19
2	6	9	11	16	20
5	8	11	13	18	22
10	12	15	17	22	26
[s]					

**Delivery condition (capacitors)**

The actuator is completely discharged after delivery from the factory, which is why the actuator requires approximately 20 s pre-charging time before initial commissioning in order to bring the capacitors up to the required voltage level.

**Bridging time**

Power failures can be bridged up to a maximum of 10 s. In the event of a power failure, the actuator will remain stationary in accordance with the set bridging time. If the power failure is greater than the set bridging time, the actuator will move into the selected fail-safe position. The bridging time set at the factory is 2 s. It can be modified on site in operation by means of the Belimo service tool MFT-P. Settings: The rotary knob must not be set to the "Tool" position! For retroactive adjustments of the bridging time with the Belimo service tool MFT-P or with the ZTH EU adjustment and diagnostic device only the values need to be entered.

**Setting fail-safe position**

The rotary knob fail-safe position can be used to adjust the desired fail-safe position 0...100% in 10% increments. The rotary knob always refers to the adapted angle of rotation range. In the event of a power failure, the actuator will move into the selected fail-safe position. Settings: The rotary knob must be set to the «Tool» position for retroactive settings of the fail-safe position with the Belimo service tool MFT-P. Once the rotary knob is set back to the range 0...100%, the manually set value will have positioning authority.

Control characteristics

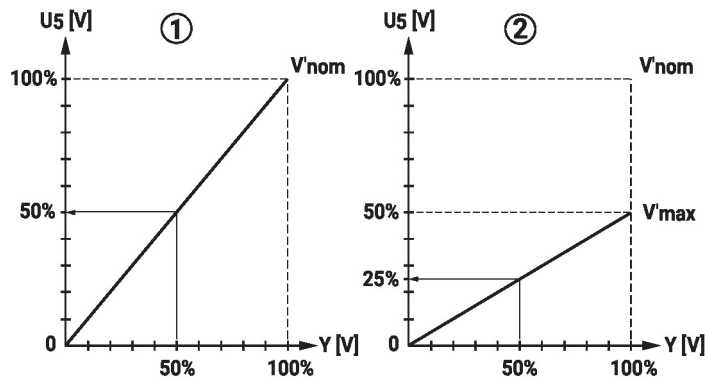

Block diagram

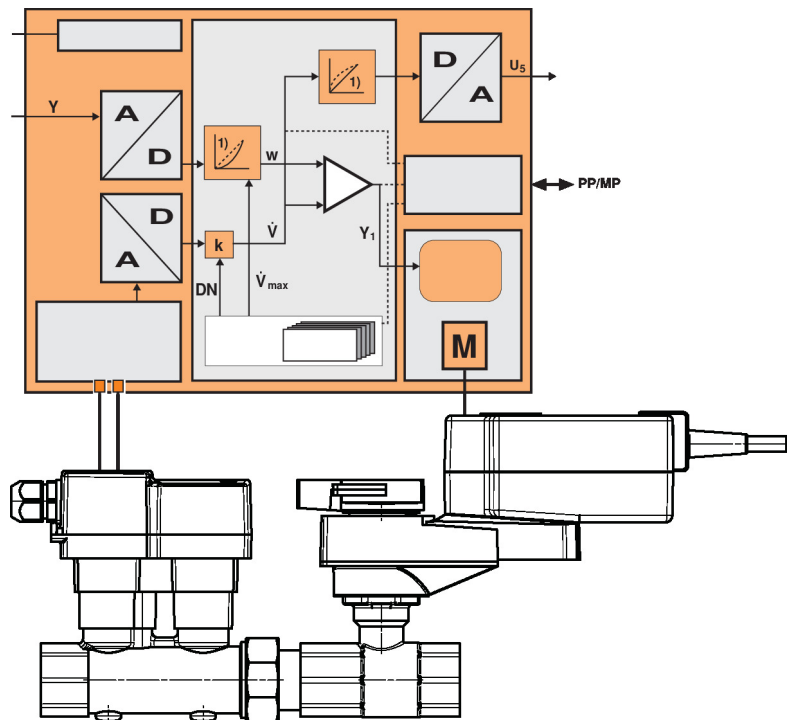

Flow control

$V'_{nom}$  is the maximum possible flow.

$V'_{max}$  is the maximum flow rate which has been set with the highest control signal DDC.

$V'_{max}$  can be set between 25% and 100% of  $V'_{nom}$ .

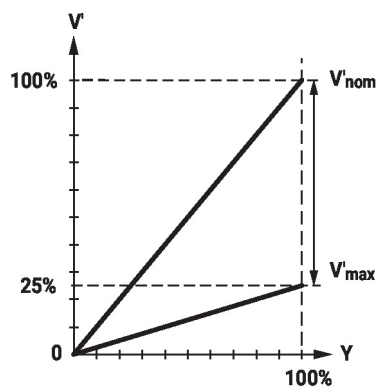

Product features

**Fluid temperature measurement** The integrated temperature sensor within the flow sensor continuously measures the medium's temperature. This measured value can be accessed through the bus system or via the analog feedback signal U. Additionally, the current temperature reading is displayed in the Belimo Assistant App.

**Creep flow suppression** Given the very low flow speed in the opening point, this can no longer be measured by the sensor within the required tolerance. This range is overridden electronically.

Opening valve

The valve remains closed until the flow required by the control signal DDC corresponds to 1% of V'nom. The control along the flow characteristic is active after this value has been exceeded.

Closing valve

The control along the flow characteristic is active up to the required flow rate of 1% of V'nom. Once the level falls below this value, the flow rate is maintained at 1% of V'nom. If the level falls below the flow rate of 0.5% of V'nom required by the control signal DDC, then the valve will close.

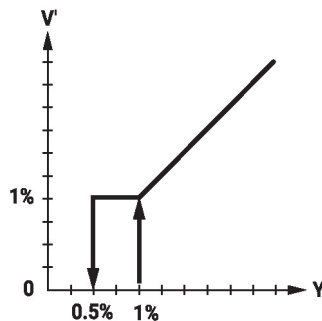

**Converter for sensors** Connection option for a sensor (active or with switching contact). In this way, the analogue sensor signal can be easily digitised and transferred to the bus systems BACnet, Modbus or MP-Bus.

**Hydronic balancing** With the Belimo tools, the maximum flow rate (equivalent to 100% requirement) can be adjusted on-site, simply and reliably, in a few steps. If the device is integrated in the management system, then the balancing can be handled directly by the management system.

**Manual override** Manual control with push-button possible - temporary. The gear train is disengaged and the actuator decoupled for as long as the button is pressed.

Accessories

Tools	Description	Type
	Converter Bluetooth / NFC	ZIP-BT-NFC

Electrical installation



Supply from isolating transformer.

The wiring of the line for BACnet MS/TP / Modbus RTU is to be carried out in accordance with applicable RS-485 regulations.

Modbus / BACnet: Supply and communication are not galvanically isolated. COM and ground of the devices must be connected to each other.

Analogue output: An analogue output (wire 5) is available on the flow sensor. It can be selected as 0...10 V, 0.5...10 V, 2...10 V or user defined. For example, the flow rate or the temperature of the temperature sensor (Pt1000 - EN 60751, 2-wire technology) can be output as an analogue value.

**Electrical installation**

AC/DC 24 V, modulating

Modbus RTU / BACnet MS/TP with analogue setpoint (hybrid operation)

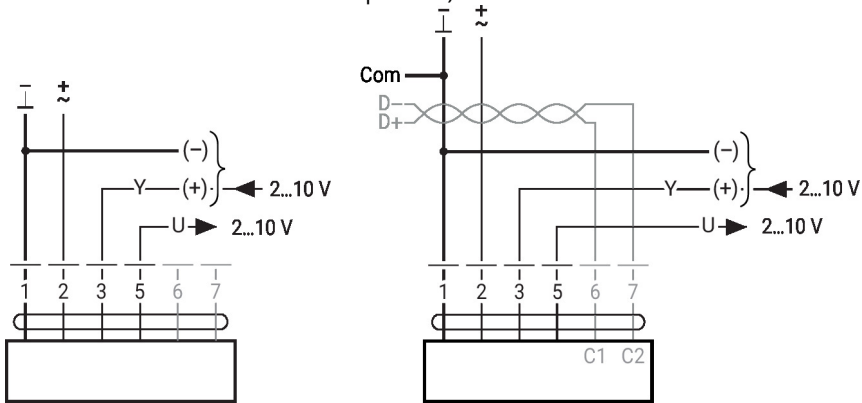

BACnet MS/TP / Modbus RTU

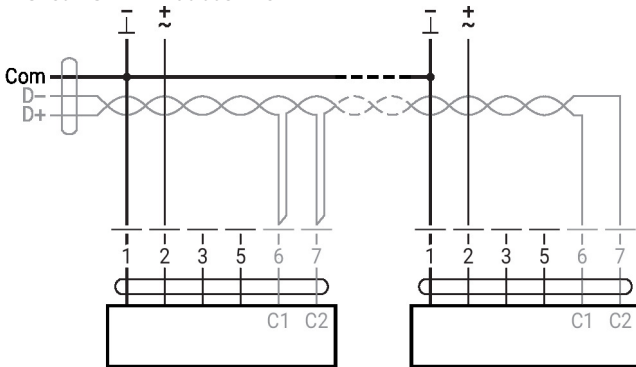

MP-Bus

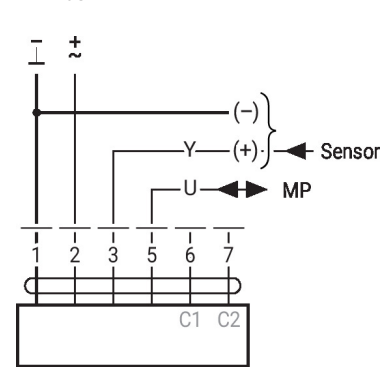

**Converter for sensors**

Connection with switching contact, e.g.  $\Delta p$  monitor

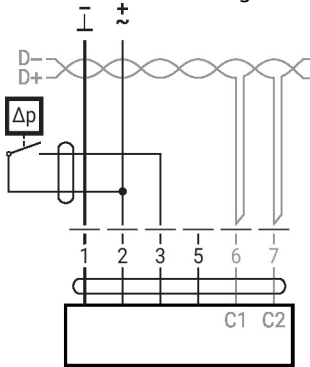

Switching contact requirements:  
The switching contact must be able to switch a current of 16 mA at 24 V accurately.

Connection with switching contact, e.g.  $\Delta p$  monitor

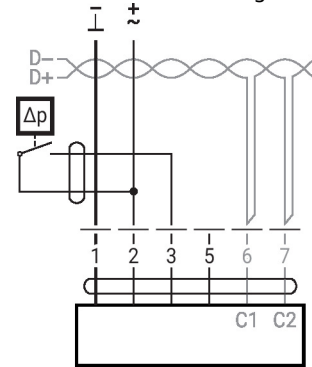

Switching contact requirements:  
The switching contact must be able to switch a current of 16 mA at 24 V accurately.

Connection with active sensor, e.g. 0...10 V @ 0...50°C

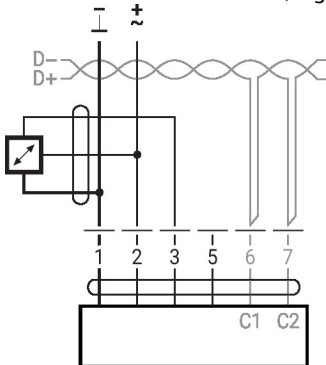

Possible voltage range: 0...32 V  
Resolution 30 mV

**Further electrical installations**

**Functions with specific parameters (parametrisation necessary)**

Override control and limiting with AC 24 V with relay contacts

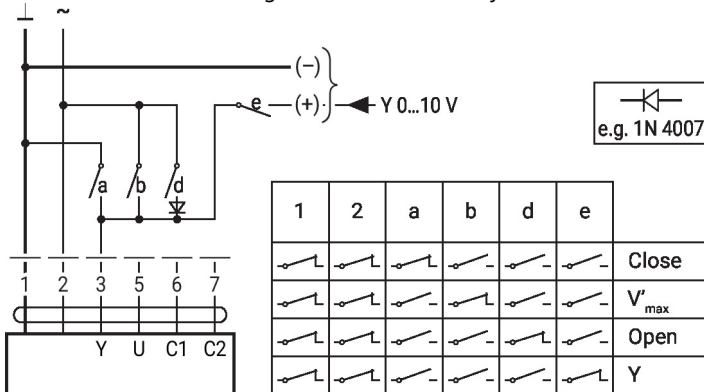

Override control and limiting with DC 24 V with relay contacts (with conventional control or hybrid mode)

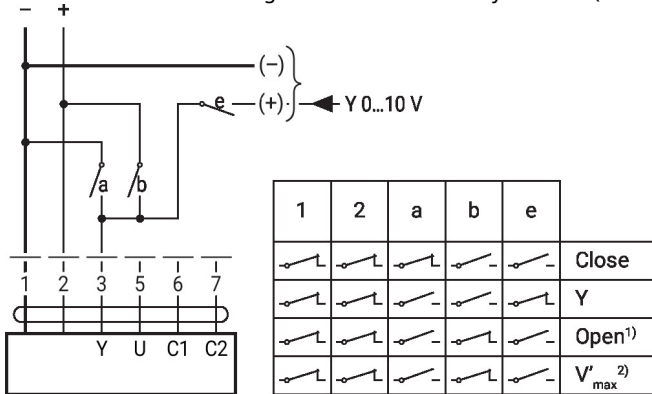

- 1) Position control
- 2) Flow control

Control 3-point with AC 24 V

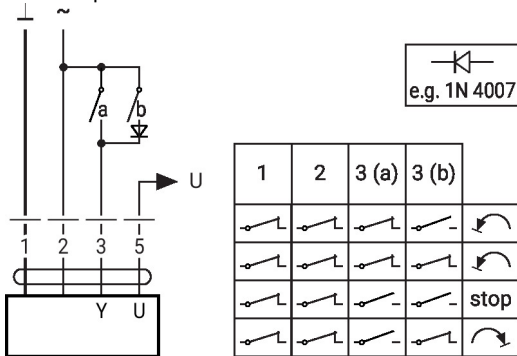

- Position control: 90° = 100s
- Flow control: Vmax = 100s

**Further electrical installations**

**Functions with specific parameters (parametrisation necessary)**

BACnet MS/TP / Modbus RTU with analogue setpoint (hybrid mode)

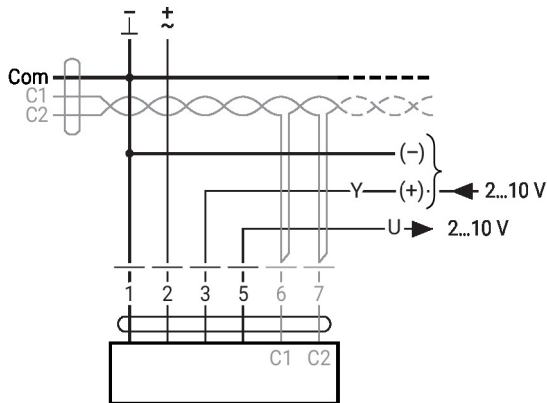

MP-Bus, supply via 3-wire connection

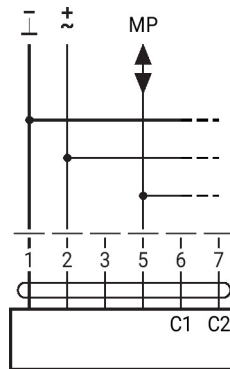

MP-Bus via 2-wire connection, local power supply

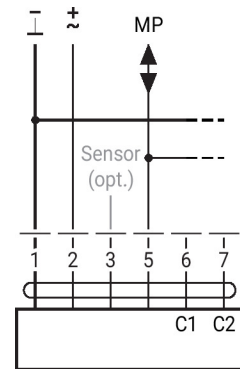

Examples of external wiring with actuator types ..24GX..

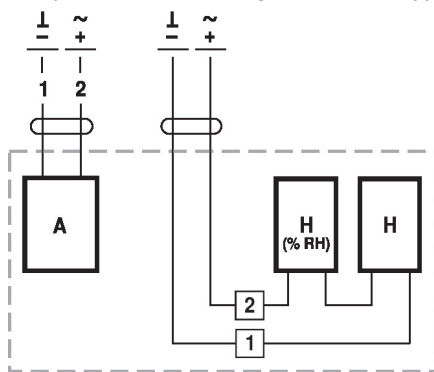

A = Actuator  
 H [% RH] = Humidistat  
 H = Heating

## Operating controls and indicators

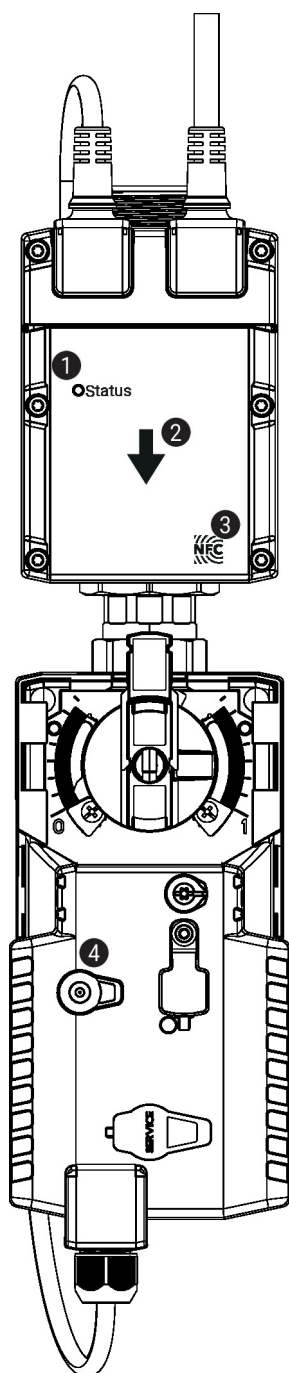
**1 LED display green**

On:	Device starting up
Off:	No power supply or wiring error
Flashing:	In operation (voltage ok)

**2 Flow direction**
**3 NFC interface**
**4 Manual override button**

Press button:	Gear train disengages, motor stops, manual override possible
Release button:	Gear train engages, standard mode. Device performs synchronisation.

Operating controls and indicators

Setting fail-safe position

Setting fail-safe position (POP)

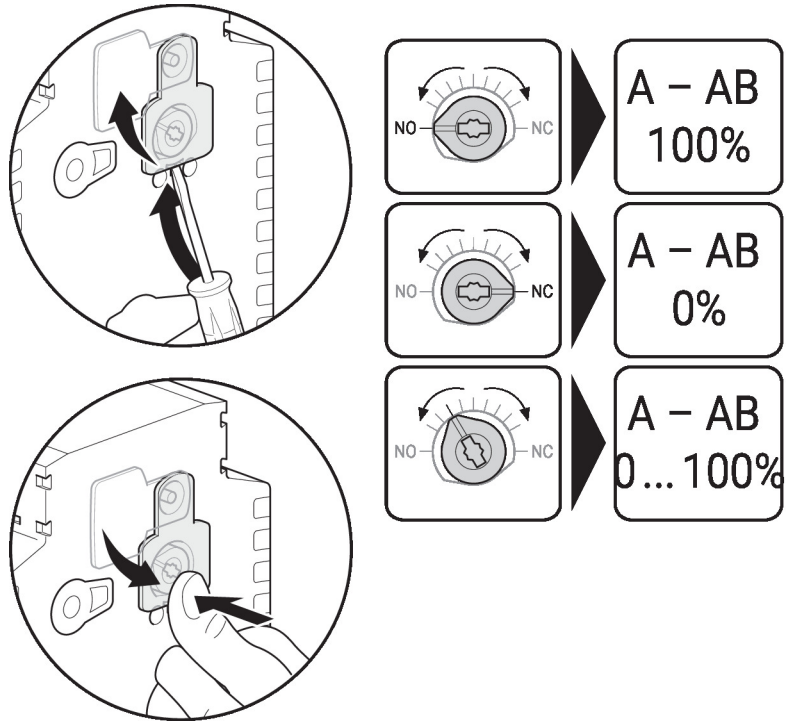

Installation notes

**Permissible installation orientation**

The ball valve can be installed upright to horizontal. The ball valve may not be installed in a hanging position, i.e. with the spindle pointing downwards.

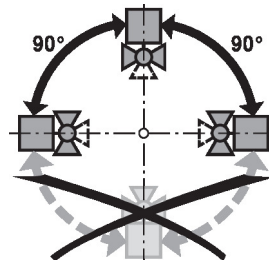

**Installation location in return**

Installation in the return is recommended.

**Water quality requirements**

The water quality requirements specified in VDI 2035 must be adhered to. Belimo valves are regulating devices. For the valves to function correctly in the long term, they must be kept free from particle debris (e.g. welding beads during installation work). The installation of a suitable strainer is recommended.

**Servicing**

Ball valves, rotary actuators and sensors are maintenance-free. Before any service work on the control element is carried out, it is essential to isolate the rotary actuator from the power supply (by unplugging the electrical cable if necessary). Any pumps in the part of the piping system concerned must also be switched off and the appropriate slide valves closed (allow all components to cool down first if necessary and always reduce the system pressure to ambient pressure level). The system must not be returned to service until the ball valve and the rotary actuator have been correctly reassembled in accordance with the instructions and the pipeline has been refilled by professionally trained personnel.

**Flow direction**

The direction of flow, specified by an arrow on the housing, is to be complied with, since otherwise the flow rate will be measured incorrectly.

## Installation notes

**Inlet section** In order to achieve the specified measuring accuracy, a flow-calming section or inflow section in the direction of the flow is to be provided upstream from the flow sensor. Its dimensions should be at least 5x DN.

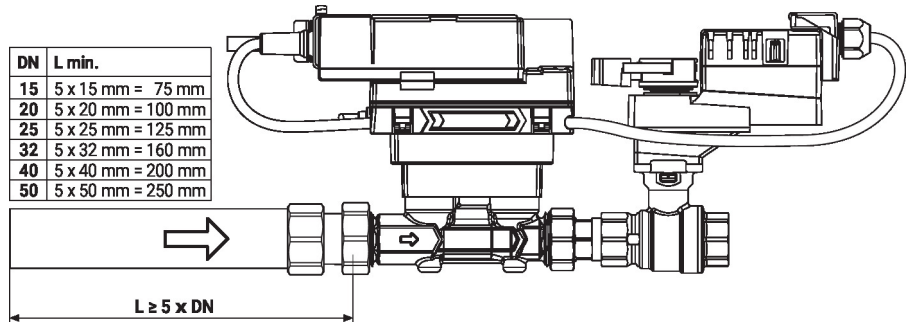

**Split installation** The valve-actuator combination may be mounted separately from the flow sensor. The direction of flow of both components must be observed.

## General notes

**Behaviour in case of sensor failure** In case of a flow sensor error, the EPIV will switch from flow control to position control. Once the error disappears, the EPIV will switch back to the normal control setting.

## Dimensions

## Dimensional drawings

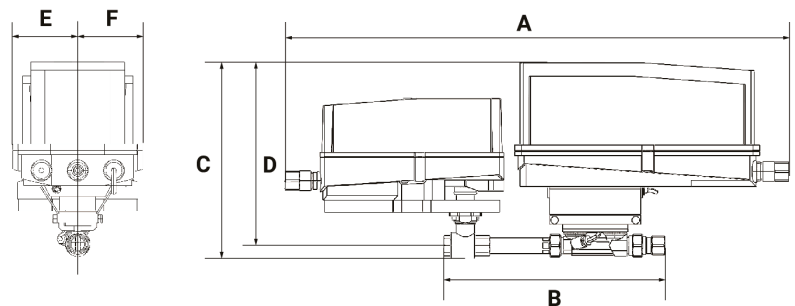

## Type

EP200H+AKRX-E N4HH

## Weight

7.4 kg

A	B	C	D	E	F
26.6" [675]	13.9" [353]	305	10.2" [260]	3.4" [86]	86