

Rotary actuator for butterfly valves

- Torque motor 160 Nm
- Nominal voltage AC 24...240 V / DC 24...125 V
- Control Open/close, 3-point
- With 2 integrated auxiliary switches



Technical data

| | | |
|------------------------|--|---|
| Electrical data | Nominal voltage | AC 24...240 V / DC 24...125 V |
| | Nominal voltage frequency | 50/60 Hz |
| | Nominal voltage range | AC 19.2...264 V / DC 19.2...137.5 V |
| | Power consumption in operation | 20 W |
| | Power consumption in rest position | 6 W |
| | Power consumption for wire sizing | with 24 V 20 VA / with 240 V 52 VA |
| | Auxiliary switch | 2x SPDT, 1x 10° / 1x 0...90° (default setting 85°) |
| | Switching capacity auxiliary switch | 1 mA...3 A (0.5 A inductive), DC 5 V...AC 250 V |
| | Connection supply / control | Terminals 2.5 mm ² |
| | Connection protective earth | earth terminal |
| | Connection auxiliary switch | Terminals 2.5 mm ² |
| | Parallel operation | Yes (note the performance data) |
| Functional data | Torque motor | 160 Nm |
| | Manual override | hand crank |
| | Running time motor | 35 s / 90° |
| | Running time motor variable | 30...120 s |
| | Sound power level, motor | 68 dB(A) |
| | Position indication | Mechanical, integrated |
| Safety data | Protection class IEC/EN | I, protective earth (PE) |
| | Protection class UL | I, protective earth (PE) |
| | Degree of protection IEC/EN | IP66/67 |
| | Degree of protection NEMA/UL | NEMA 4X |
| | Enclosure | UL Enclosure Type 4X |
| | EMC | CE according to 2014/30/EU |
| | Low voltage directive | CE according to 2014/35/EU |
| | Certification IEC/EN | IEC/EN 60730-1 and IEC/EN 60730-2-14 |
| | UL Approval | cULus according to UL60730-1A, UL60730-2-14 and CAN/CSA E60730-1 The UL marking on the actuator depends on the production site, the device is UL-compliant in any case |
| | Type of action | Type 1 |
| | Rated impulse voltage auxiliary switch | 2.5 kV |
| | Pollution degree | 3 |
| | Ambient humidity | Max. 100% RH |
| | Ambient temperature | -30...50°C [-22...122°F] |

Technical data

| | | |
|------------------------|---------------------|-----------------------------------|
| Safety data | Storage temperature | -40...80°C [-40...176°F] |
| | Servicing | maintenance-free |
| Mechanical data | Connection flange | F07 (F05/F10 only with accessory) |
| Weight | Weight | 5.8 kg |

Safety notes

- This device has been designed for use in stationary heating, ventilation and air-conditioning systems and must not be used outside the specified field of application, especially in aircraft or in any other airborne means of transport.
- Caution: Power supply voltage!
- The device has a protective earthing. Incorrect connection of the protective earth can lead to hazards due to electrical shock.
- Only authorised specialists may carry out installation. All applicable legal or institutional installation regulations must be complied with during installation.
- Apart from the connection box, the device may only be opened at the manufacturer's site. It does not contain any parts that can be replaced or repaired by the user.
- The device contains electrical and electronic components and must not be disposed of as household refuse. All locally valid regulations and requirements must be observed.
- The two switches integrated in the actuator are to be operated either on power supply voltage or at safety extra-low voltage. The combination power supply voltage/safety extra-low voltage is not permitted.

Product features

| | |
|------------------------------------|--|
| Fields of application | The actuator is particularly suitable for utilisation in outdoor applications and is protected against the following weather conditions: - UV radiation - Dirt / Dust - Rain / Snow - Air humidity |
| Internal heating | An internal heater prevents condensation buildup. Thanks to the integrated temperature and humidity sensor, the built-in heater automatically switches on/off. |
| Parametrisable actuators | The factory settings cover the most common applications. The Belimo Assistant App is required for parametrisation via Near Field Communication (NFC) and simplifies commissioning. Moreover, it provides a variety of diagnostic options. The ZTH EU service tool provides a selection of both diagnostic and setting options. |
| Simple direct mounting | Simple direct mounting on the butterfly valve. The mounting orientation in relation to the butterfly valve can be selected in 90° (angle) increments. |
| Manual override | The valve can be manually operated using a hand crank. Unlocking is carried out manually by removing the hand crank. |
| High functional reliability | The actuator is overload protected, requires no limit switches and automatically stops when the end stop is reached. |
| Flexible signalling | The actuator has one auxiliary switch with a fixed setting (10°) and one adjustable auxiliary switch (0...90°). |

Accessories

| Mechanical accessories | Description | Type |
|------------------------|---|----------------------|
| | Position indicator and tappet shaft, F07, square 45° offset, SW 17, DN 125...300 | ZPR01 |
| | Tappet shaft, F07, square 45° offset, SW 17 | ZPR02 |
| | Position indicator and tappet shaft, F05, square 45° offset, SW 14, DN 80...100 | ZPR03 |
| | RetroFIT+ adapter kit, F07/F10 (incl. screws F07), flat head/square, SW 17 | ZPR05 |
| | RetroFIT+ adapter kit, F07/F10 (incl. screws F07), square 45° offset, SW 14 | ZPR06 |
| | Adapter kit with spacer ring, F07, square 45° offset, SW 17 | ZPR08 |
| | RetroFIT+ adapter kit, F07/F05/F10 (incl. screws F07), flat head/square, SW 14 | ZPR09 |
| | RetroFIT+ adapter kit, F05/F07/F10 (incl. screws F05), flat head/square, SW 14 | ZPR10 |
| | RetroFIT+ adapter kit, F07/F10 (incl. screws F07), square 45° offset, SW 18 | ZPR11 |
| | RetroFIT+ adapter kit, F07/F10 (incl. screws F07), flat head/square, SW 16 | ZPR12 |
| | RetroFIT+ adapter kit, F07/F05/F10 (incl. screws F07), flat head/square, SW 11 | ZPR13 |
| | RetroFIT+ adapter kit, F07/F05/F10 (incl. screws F07), flat head/square, SW 12.7 | ZPR14 |
| | RetroFIT+ adapter kit, F07/F10 (incl. screws F07), square 45° offset, SW 11 | ZPR15 |
| | Hand crank for PR/PM/JR actuator | ZPR20 |
| | Spacer ring, F04/F05, Height 22 mm | ZRI-001 |
| | Spacer ring, F05/F07, Height 23.5 mm | ZRI-002 |
| Tools | Description | Type |
| | Belimo Assistant App, Smartphone app for easy commissioning, parametrising and maintenance | Belimo Assistant App |
| | Converter Bluetooth / NFC | ZIP-BT-NFC |
| | Service tool, with ZIP-USB function, for parametrisable and communicative Belimo actuators, VAV controller and HVAC performance devices | ZTH EU |
| | Connecting cable 5 m, A: RJ11 6/4 ZTH EU, B: 6-pin for connection to service socket | ZK1-GEN |

Electrical installation



Caution: Power supply voltage!

Parallel connection of other actuators possible. Observe the performance data.

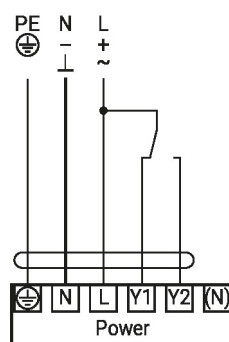
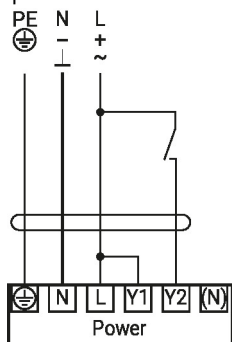
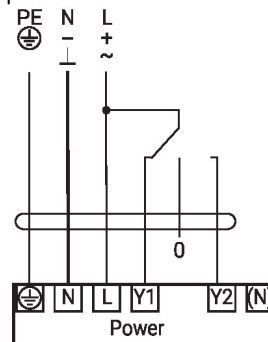
Wiring diagrams

 AC 24...240 V / DC 24...125 V,
open/close

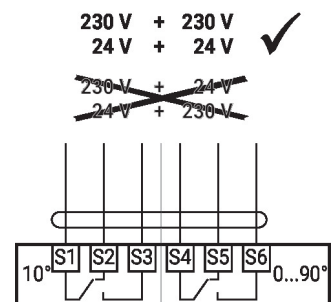
 AC 24...240 V / DC 24...125 V, 3-
point

Auxiliary switch

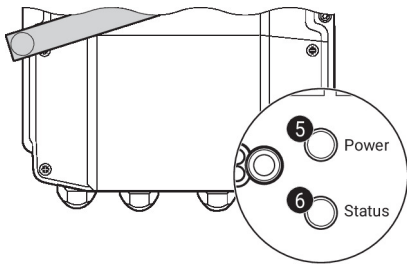

Operating controls and indicators

5 Push-button and LED display green

- Off: No power supply or malfunction
 On: In operation
 Press button: Triggers test run, followed by standard mode

6 Push-button and LED display yellow

- Off: Standard mode
 On: Test run active

Auxiliary switch settings



Note: Perform settings on the actuator only in deenergised state.

For the auxiliary switch position settings, carry out points **1** to **4** successively.

1 Gear train disengagement

Opening the manual override cover and adjusting the hand crank.
 Manual override is possible.

2 Manual override

Turn the hand crank until the desired switching position **A** is indicated and then remove the hand crank.

3 Auxiliary switch

For the auxiliary switch position settings, carry out points **1** to **4** successively.
 Opening the auxiliary switch adjustment cover and adjusting the hand crank.
 Turn the hand crank until the arrow points to the vertical line.

4 Terminals

Connect continuity tester to S4 + S5 or to S4 + S6.
 If the auxiliary switch should switch in the opposite direction, rotate the hand crank by 180°.

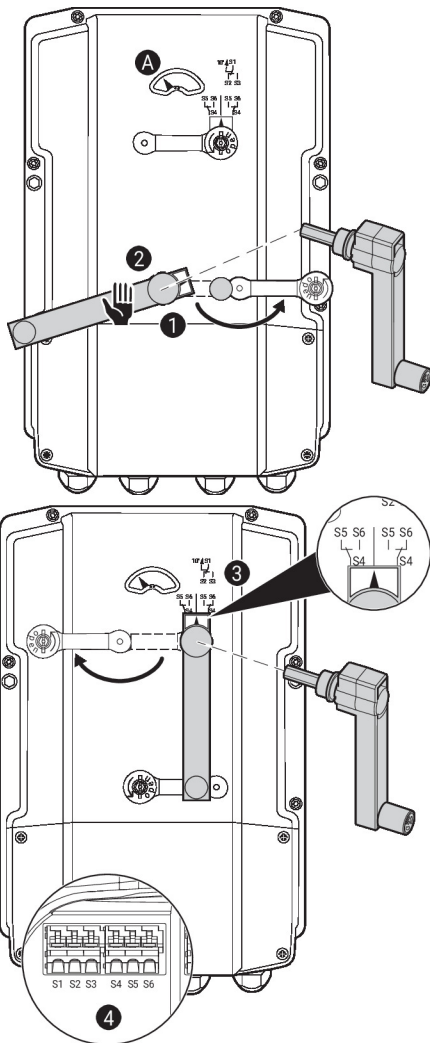

Service

NFC connection Belimo devices marked with the NFC logo can be operated with the Belimo Assistant App.

Requirement:

- NFC- or Bluetooth-capable smartphone
- Belimo Assistant App (Google Play & Apple AppStore)

Align NFC-capable smartphone on the device so that both NFC antennas are superposed.

Connect Bluetooth-enabled smartphone via the Bluetooth-to-NFC Converter ZIP-BT-NFC to the device. Technical data and operation instructions are shown in the ZIP-BT-NFC data sheet.

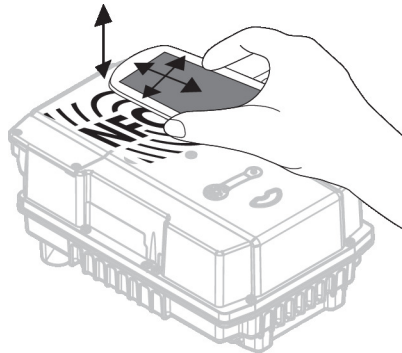

Tool connection The actuator can be configured by the ZTH EU via the service socket.

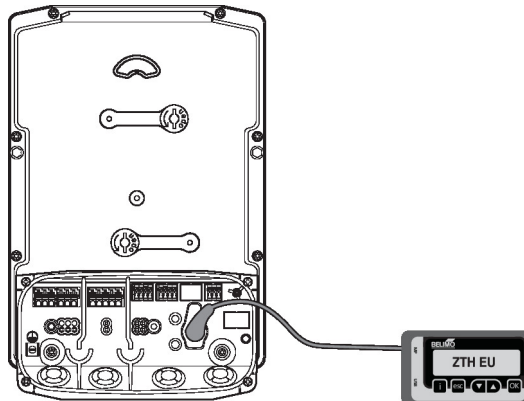

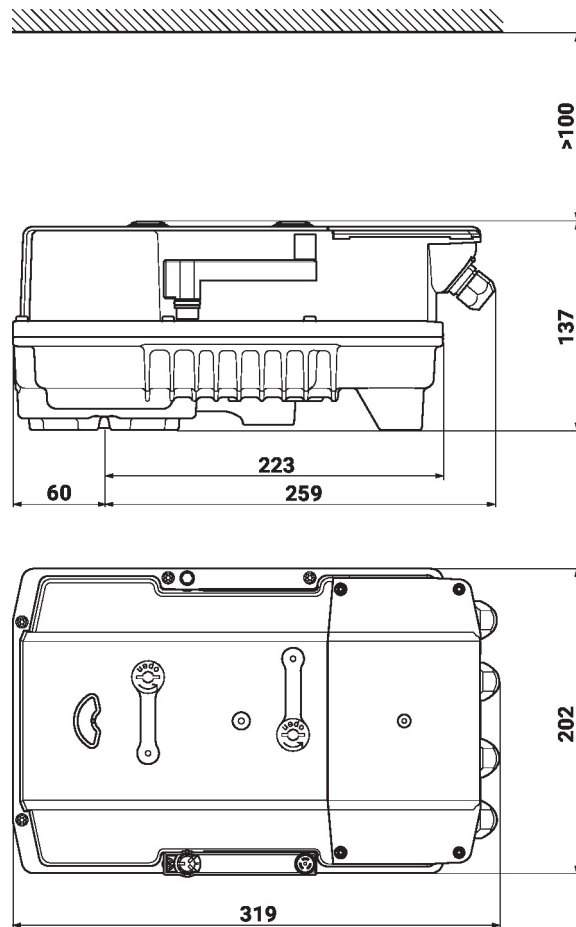
Dimensions

Further documentation

- The complete product range for water applications
- Data sheets for butterfly valves
- Installation instructions for actuators and/or butterfly valves
- General notes for project planning