

Characterised control valve, 6-way, Internal thread

- Two sequences (cooling/heating) with one 90° rotary actuator
- Switching or modulating control on the water side of thermal heating/cooling elements
- For closed cold and warm water systems



Type overview

Type	DN	Rp ["]	kvs (Sequence 1) [m³/h]	kvs (Sequence 2) [m³/h]	PN
R3015-P25-P25-B2	15	1/2	0.25	0.25	16
R3015-P25-P4-B2	15	1/2	0.25	0.4	16
R3015-P25-P63-B2	15	1/2	0.25	0.63	16
R3015-P25-1-B2	15	1/2	0.25	1	16
R3015-P25-1P3-B2	15	1/2	0.25	1.3	16
R3015-P25-1P8-B2	15	1/2	0.25	1.8	16
R3015-P4-P25-B2	15	1/2	0.4	0.25	16
R3015-P4-P4-B2	15	1/2	0.4	0.4	16
R3015-P4-P63-B2	15	1/2	0.4	0.63	16
R3015-P4-1-B2	15	1/2	0.4	1	16
R3015-P4-1P3-B2	15	1/2	0.4	1.3	16
R3015-P4-1P8-B2	15	1/2	0.4	1.8	16
R3015-P63-P25-B2	15	1/2	0.63	0.25	16
R3015-P63-P4-B2	15	1/2	0.63	0.4	16
R3015-P63-P63-B2	15	1/2	0.63	0.63	16
R3015-P63-1-B2	15	1/2	0.63	1	16
R3015-P63-1P3-B2	15	1/2	0.63	1.3	16
R3015-P63-1P8-B2	15	1/2	0.63	1.8	16
R3015-1-P25-B2	15	1/2	1	0.25	16
R3015-1-P4-B2	15	1/2	1	0.4	16
R3015-1-P63-B2	15	1/2	1	0.63	16
R3015-1-1-B2	15	1/2	1	1	16
R3015-1-1P3-B2	15	1/2	1	1.3	16
R3015-1-1P8-B2	15	1/2	1	1.8	16
R3015-1P3-P25-B2	15	1/2	1.3	0.25	16
R3015-1P3-P4-B2	15	1/2	1.3	0.4	16
R3015-1P3-P63-B2	15	1/2	1.3	0.63	16
R3015-1P3-1-B2	15	1/2	1.3	1	16
R3015-1P3-1P3-B2	15	1/2	1.3	1.3	16
R3015-1P3-1P8-B2	15	1/2	1.3	1.8	16
R3015-1P8-P25-B2	15	1/2	1.8	0.25	16
R3015-1P8-P4-B2	15	1/2	1.8	0.4	16
R3015-1P8-P63-B2	15	1/2	1.8	0.63	16
R3015-1P8-1-B2	15	1/2	1.8	1	16
R3015-1P8-1P3-B2	15	1/2	1.8	1.3	16
R3015-1P8-1P8-B2	15	1/2	1.8	1.8	16
R3020-P63-1P6-B2	20	3/4	0.63	1.6	16
R3020-P63-2P5-B2	20	3/4	0.63	2.5	16
R3020-P63-4-B2	20	3/4	0.63	4	16
R3020-1-1P6-B2	20	3/4	1	1.6	16
R3020-1-2P5-B2	20	3/4	1	2.5	16
R3020-1-4-B2	20	3/4	1	4	16
R3020-1P6-P63-B2	20	3/4	1.6	0.63	16
R3020-1P6-1-B2	20	3/4	1.6	1	16

Type	DN	Rp ["]	kvs (Sequence 1) [m ³ /h]	kvs (Sequence 2) [m ³ /h]	PN
R3020-1P6-1P6-B2	20	3/4	1.6	1.6	16
R3020-1P6-2P5-B2	20	3/4	1.6	2.5	16
R3020-1P6-4-B2	20	3/4	1.6	4	16
R3020-2P5-P63-B2	20	3/4	2.5	0.63	16
R3020-2P5-1-B2	20	3/4	2.5	1	16
R3020-2P5-1P6-B2	20	3/4	2.5	1.6	16
R3020-2P5-2P5-B2	20	3/4	2.5	2.5	16
R3020-2P5-4-B2	20	3/4	2.5	4	16
R3020-4-P63-B2	20	3/4	4	0.63	16
R3020-4-1-B2	20	3/4	4	1	16
R3020-4-1P6-B2	20	3/4	4	1.6	16
R3020-4-2P5-B2	20	3/4	4	2.5	16
R3020-4-4-B2	20	3/4	4	4	16
R3025-6P3-6P3-B3	25	1	6.3	6.3	16

Technical data

Functional data	Fluid	Cold and warm water, water with glycol up to max. 50% vol.	
	Fluid temperature	6...80°C [43...176°F]	
	Close-off pressure Δp_s	350 kPa	
	Differential pressure Δp_{max}	100 kPa	
	Differential pressure note	low-noise operation $\Delta p_{v100} < 50\text{kPa}$	
	Flow characteristic	linear	
	Leakage rate	air-bubble tight, leakage rate A (EN 12266-1)	
	Angle of rotation	90°	
	Angle of rotation note	Sequence 1: 0...30° (Cooling recommended) Dead zone: 30...60° Sequence 2: 60...90° (Heating recommended)	
	Pipe connection	Internal thread according to ISO 7-1	
	Installation position	upright to horizontal (in relation to the stem)	
	Servicing	maintenance-free	
	Materials	Valve body	Nickel-plated brass body
		Body finish	nickel-plated
Closing element		Chrome-plated brass	
Spindle		Nickel-plated brass	
Spindle seal		EPDM O-ring	
Seat		PTFE, O-ring EPDM	
Flow rate diaphragms		stainless steel	

Safety notes

- The valve has been designed for use in stationary heating, ventilation and air-conditioning systems and must not be used outside the specified field of application, especially in aircraft or in any other airborne means of transport.
- Only authorised specialists may carry out installation. All applicable legal or institutional installation regulations must be complied during installation.
- The valve does not contain any parts that can be replaced or repaired by the user.
- The valve may not be disposed of as household refuse. All locally valid regulations and requirements must be observed.
- When determining the flow rate characteristic of controlled devices, the recognised directives must be observed.

Product features

- Mode of operation** The 6-way characterised control valve is adjusted by a rotary actuator. The actuator is connected by a modulating control system or a bus signal and moves the ball of the ball valve to the position dictated by the control signal.
If the valve is adjusted in the clockwise direction (till the end stop), e.g. the cooling sequence is completely enabled; if the valve is adjusted in the counter-clockwise direction (90°), e.g. the heating sequence is completely enabled.
- Pressure compensation** In cases of combined heating/cooling control elements, the fluid remains in the control element when in the closed position (no heating or cooling). The pressure of the enclosed fluid can rise or fall due to changes in fluid temperature caused by the ambient temperature. The 6-way characterised control valves have an integrated pressure relief function for the purpose of compensating for such pressure changes.
The pressure relief function is active in the closed position (45°) of the valve; reliable separation of Sequences 1 and 2 continues. For additional information, consult the notes for project planning for the 6-way characterised control valve.

Accessories

Mechanical accessories	Description	Type
	Elbow 90° male/female DN 15 Rp 1/2, R 1/2, Set of 2 pcs.	P2P15PE-1GE
	Fixing bracket for 6-way valve DN 15/20	ZR-004
	Pipe connector for ball valve DN 15	ZR2315
	Elbow 90° male/female DN 20 Rp 3/4, R 3/4, Set of 2 pcs.	P2P20PF-1GE
	Pipe connector for ball valve DN 20	ZR2320
	Elbow 90° male/female DN 25 Rp 1, R 1, Set of 2 pcs.	P2P25PE-1GE
	Fixing bracket for 6-way valve DN 25	ZR-005
	Pipe connector for ball valve DN 25	ZR2325

Installation notes

- Recommended installation positions** The ball valve can be installed upright to horizontal. The ball valve may not be installed in a hanging position, i.e. with the spindle pointing downwards.

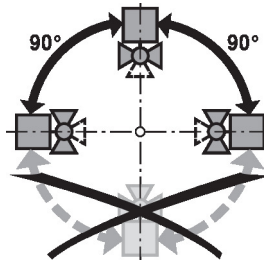

- Water quality requirements** The water quality requirements specified in VDI 2035 must be adhered to.
Belimo valves are regulating devices. For the valves to function correctly in the long term, they must be kept free from particle debris (e.g. welding beads during installation work). The installation of a suitable strainer is recommended.
- Servicing** Ball valves and rotary actuators are maintenance-free.
Before any service work on the control element is carried out, it is essential to isolate the rotary actuator from the power supply (by unplugging the electrical cable if necessary). Any pumps in the part of the piping system concerned must also be switched off and the appropriate slide valves closed (allow all components to cool down first if necessary and always reduce the system pressure to ambient pressure level).
The system must not be returned to service until the ball valve and the rotary actuator have been correctly reassembled in accordance with the instructions and the pipeline has been refilled by professionally trained personnel.

Flow direction The flow direction must be observed. The position of the ball can be identified from the L-marking on the spindle.

Heating and cooling in position accuracy

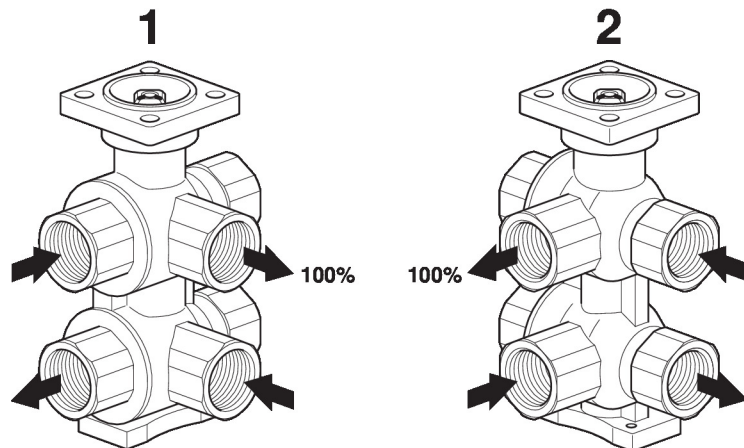

Valve characteristic curve The lower diagram shows the valve characteristic curve in relation to the ball position.

Valve characteristic curve

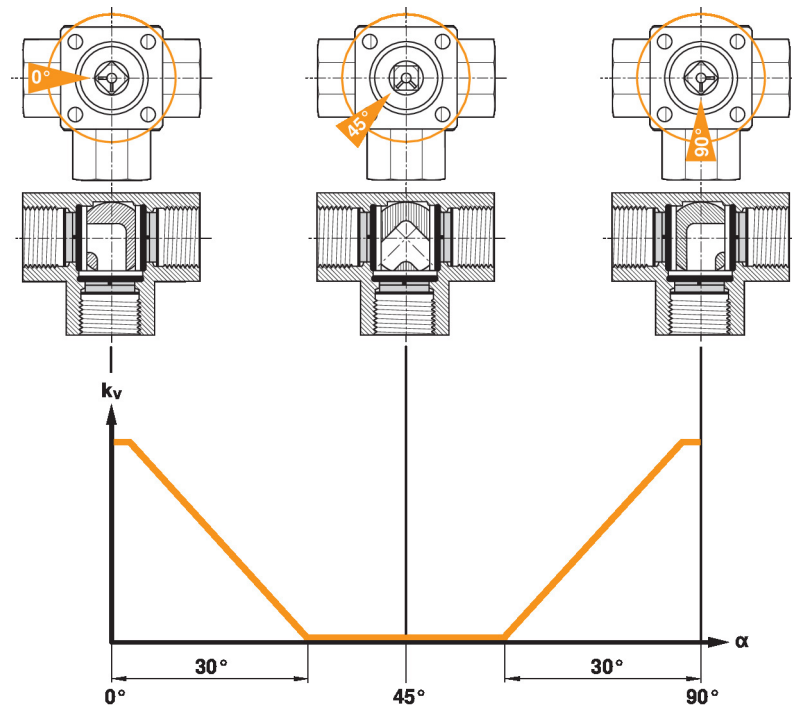

Using an additional flow limiter When using additional flow limiting valves (e.g. PIQCV C2..QP(T).. with manual flow rate setting) or an additional pressure-independent control valve (e.g. motorised PIQCV) at the system level, it is not necessary to use the flow characterised disc in the 6-way valve in the system to reduce the kvs value.

Dimensions

Dimensional drawings

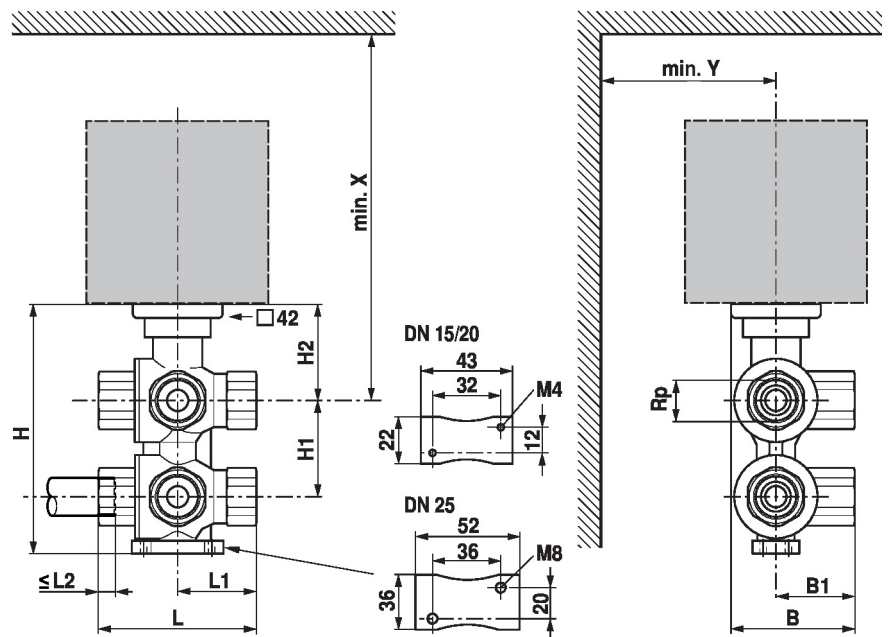

The actuator dimensions can be found on the respective actuator data sheet.

Type	DN	Rp ["]	L [mm]	L1 [mm]	L2 [mm]	B [mm]	B1 [mm]	H [mm]	H1 [mm]	H2 [mm]	X [mm]	Y [mm]	kg
R3015...-B2	15	1/2	79	39.5	13	54	33	118	45	45	200	40	0.99
R3020...-B2	20	3/4	100	50	14	70	43	146	59	52	230	40	2.0
R3025...-B3	25	1	120	60	16	84.5	52	171	69	60	270	60	3.6

Further documentation

- The complete product range for water applications
- Data sheets for actuators
- Installation instructions for actuators and/or ball valves
- Notes for project planning for 6-way characterised control valves