

Gas monitor

Belimo gas monitors are factory calibrated and can monitor up to two gases simultaneously. All monitors feature audible and visual alarms and CAN bus communication, allowing for standalone operation and networking of up to 32 devices. Select models feature relays and analog outputs to control ventilation directly, as well as BACnet MS/TP allowing for integration into a BMS. All gas monitors are wired via a daisy chain and are backed by a five-year warranty.



5-year warranty



Type Overview

Type	Measured values	Number of relays	Number of analog outputs	Communication
22G15-5A5	CO ₂	1	2	CAN bus, BACnet MS/TP
22G15-5B5	CO ₂	2	0	CAN bus, BACnet MS/TP

Technical data

Electrical Data	Nominal voltage	AC 24 V
	Nominal voltage note	Please see the remarks section for nominal voltage details and nominal voltage range.
	Nominal voltage frequency	50/60 Hz
	Power consumption AC	5 VA
	Cable entry	2 top, 2 bottom, 1 rear – 1/2" EMT
	Cable specification	Power cable: 18...20 AWG Communication cable: 22...24 AWG twisted pair, shielded jacketed, low capacitance Please see the remarks section for more information about cable size and polarity.
	Fuse	Thermal PTC, auto-reset
Data bus communication	Communication	CAN bus BACnet MS/TP
Functional Data	Application	Air
	Output signal active note	Analog outputs: 2...10 V or 4...20 mA, user selectable with jumper
	Output signal relay note	Relays: SPDT, 5A @ AC 125 V, non-inductive Please see Remarks section for relay rating.
	Mounting	Install between 1 m [3 ft] from the floor to half of the ceiling height
	Max. altitude	6562 ft [2000 m] above sea level
	Max. altitude note	Calibration verification is recommended above 2000 ft [610 m]

Technical data

Functional Data	Coverage area	Radius: 15 m [50 ft] Area: 700 m ² [7500 ft ²] There can be no obstructions such as walls, elevators, stairs, shelving with solid fill, tool chests, etc. Otherwise the time weighted average (TWA) for the gas to reach the monitor will increase.
	Display	LCD with backlight showing gas type, gas concentration, alarm level status
	Alarm	Alarm level 1: Visual alarm (red LED) Alarm level 2: Visual alarm (red LED) Alarm level 3: Visual and audible alarm (flashing white strobe LED and horn) Horn: 80 dB @ 1 m [3.3ft]
	Warm-up time	10 minutes
Measuring Data	Measured values	CO ₂
Specification gas	Sensing element technology	Non-dispersive infrared (NDIR) dual-channel
	Measuring range	CO ₂ : 0...5,000 ppm
	Calibration	Non-interactive zero and span Sensor modules are required to be calibrated annually.
	Typical response time	<105 s (T90)
Specification Temperature	Measuring range	-4...104°F [-20...40°C] Please see the remarks section for the application notice for temperature sensor
Specification Temperature	Accuracy temperature passive	±7°C @ 23.5°C [13°F @ 74°F] Please see the Remarks section under Application Notice for more information about temperature accuracy
Safety Data	Agency Listing	cCSAus listed to C22.2 No. 61010-1-12, UL Std. No. 61010-1 (3rd Edition), harmonized under IEC/EN 61010-1 BTL listed No. BTL-30001
	Pollution degree	2
	Ambient humidity	15...90% RH continuous, 0...99% RH intermittent, non-condensing
	Ambient temperature	-20...40°C [-4...104°F]
Materials	Housing	UL94 5VA

Remarks

- Nominal voltage details** All Belimo gas monitors, communication modules, and relay units can be powered by AC/DC 24 V. Under CSA/UL 61010-1 all gas monitors and communication modules are rated to AC 24 V only. Under ULC-S588 and UL 2075, all vehicle emissions gas monitors (CO, NO₂, CO + NO₂) are rated to AC/DC 24 V.
- Nominal voltage range** All Belimo gas monitors, communication modules, and relay units have a nominal voltage range of AC 17...28/DC 21...38 V (not UL or CSA-tested), AC/DC 20.4...26.4 V (UL-tested).

Remarks

- Power cable size and polarity** Terminal blocks can accommodate one 14...20 AWG wire, or two 18...20 AWG wires in the same terminal. Please take cable and transformer size into account to provide adequate voltage. Maintain the same polarity between devices at full power (AC/DC 24 V).
- Communication cable size and polarity** CAN bus and BACnet MS/TP communication cables should be 22...24 AWG, twisted-pair, shield-jacketed, low-capacitance. Please consider the CAN bus baud rate (programmable setting No. 68) and BACnet the MS/TP baud rate (programmable setting No. 48) to provide working communications. For all communication wiring, maintain the same polarity and baud rate between all devices on the network.
- Relay rating** All relays used in Belimo gas monitors, communication modules, and relay units are rated for: SPDT, 5 A @ AC 125 V, non-inductive (UL/CSA tested), and SPDT, 4 A @ DC 24 V, non-inductive (not UL/CSA tested).
- Application notice for temperature sensor** All Belimo gas monitors and communication modules come with an internal temperature sensor. The purpose of this temperature sensor is to protect an enclosed parking garage from overheating or freezing, by activating relay 1. When using this feature, it is recommended to calibrate the temperature sensor to the ambient temperature (programmable setting No. 50), after the gas monitor has been powered for 24 hours. For freeze protection, it is recommended to set the temperature set point (programmable settings No. 55) at or over 40 °F [4°C].

Please note that this temperature sensor is located on the gas monitor printed circuit board (PCB). Therefore, it needs to be calibrated after 24 hours of normal operation to offset the heat generated by the PCB. It is not intended to be used as a room temperature sensor because of the limited accuracy and slow response time caused by its location on the PCB. This temperature sensor accuracy of ±13°F @ 74°F [7°C @ 23.5°C] has not been certified by UL.
- Application notice for gas sensors** Intended applications include residential, light commercial, and light industrial. Non-intended applications include heavy commercial, heavy industrial, or hazardous locations.

Indoor air quality (CO2):
Breweries, indoor greenhouses, grow farms, warehouses

Accessories

Replacement sensor modules	Description	Type
	Sensor module CO ₂ (Carbon Dioxide), 0...5000 ppm, Dual channel auto calibration	R-G15-005
Electrical accessories	Description	Type
	Communication module, CAN bus, BACnet MS/TP, 1 relay, 2 analog outputs	C-22G-5A
	Communication module, CAN bus, BACnet MS/TP, 2 relays	C-22G-5B
	Communication module, CAN bus	C-22G-5C
	Relay unit, CAN bus, 4 relays	C-22G-50
	High-low mounting kit	A-22G-A14
	External visual alarm	A-22G-A15
	External audible alarm	A-22G-A16
	Transformer, 50 VA	A-22G-A50
	Transformer, 100 VA	A-22G-A100
Mechanical accessories	Description	Type
	Splash proof enclosure	A-22G-A12
	Duct mount enclosure	A-22G-A13
	Calibration kit,	A-22G-A22

Wiring Diagram

A Model Wiring

22G..-5A / C-22G-5A

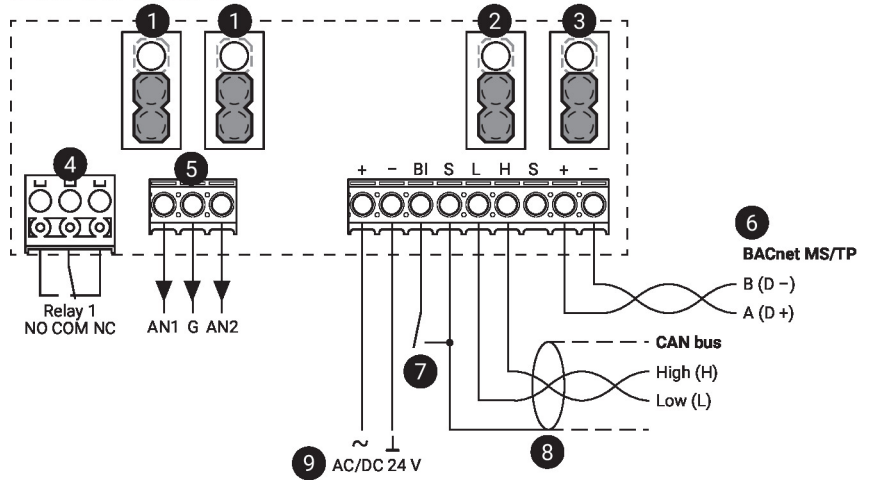

B Model Wiring

22G..-5B / C-22G-5B

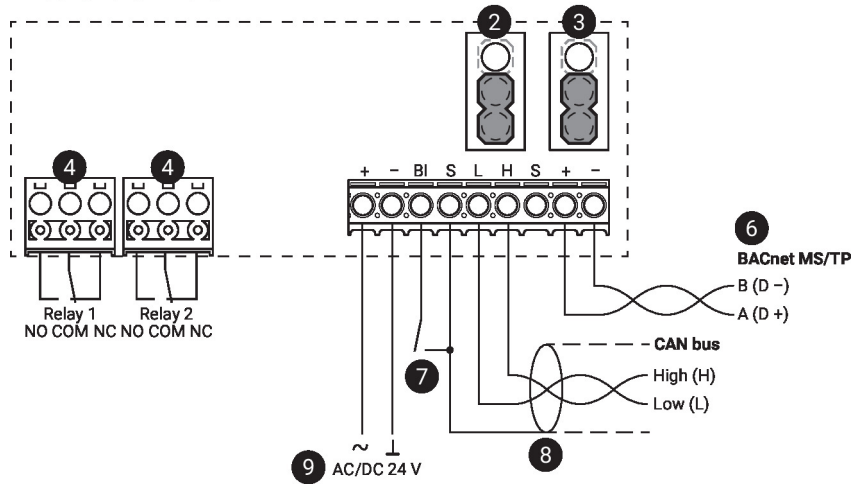

C Model Wiring

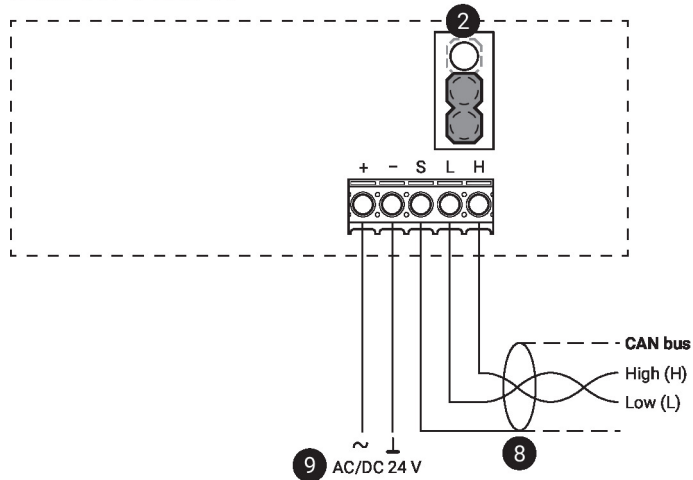
22G..-5C / C-22G-5C

- 1 Analog outputs**
 Down position: 2....10 V (factory setting)
 Up position: 4...20 mA
- 2 End of line (EOL) jumper: CAN bus**
 Down position: Termination OFF (factory setting)
 Up position: Termination ON (first and last unit only should have this jumper in the up position)
- 3 End of line (EOL) jumper: MS/TP**
 Down position: Termination OFF (factory setting)
 Up position: Termination ON (first and last unit only should have this jumper in the up position)
- 4 Relay output**
- 5 Analog output**
- 6 Shield connected at the first unit only, at others only looped through**
- 7 Binary input to limit switch**
- 8 Shield connected at the first unit only, at others only looped through**
- 9 No connection to the ground**

Wiring CAN bus CAN bus Wiring

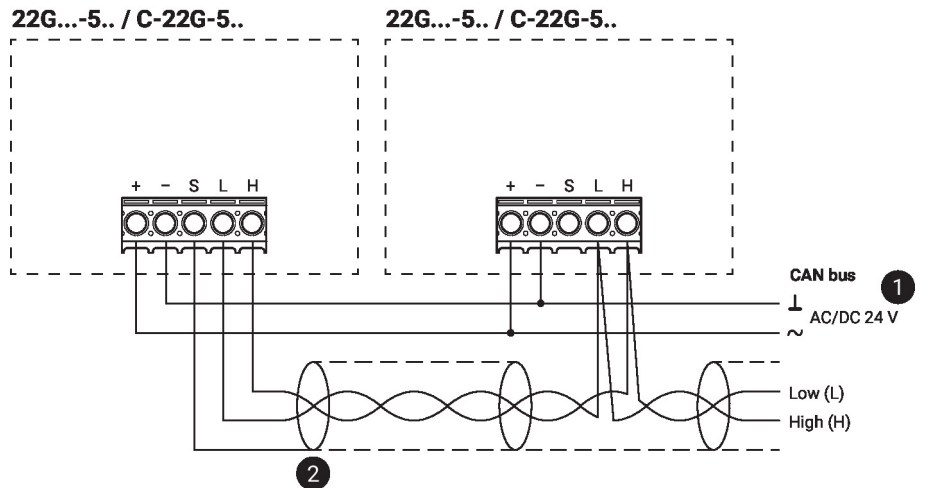

- 1 No connection to the ground
- 2 Shield connected at the first unit only, at others only looped through

Wiring Diagram

wiring RS485 BACnet MS/TP

BACnet MS/ TP Wiring

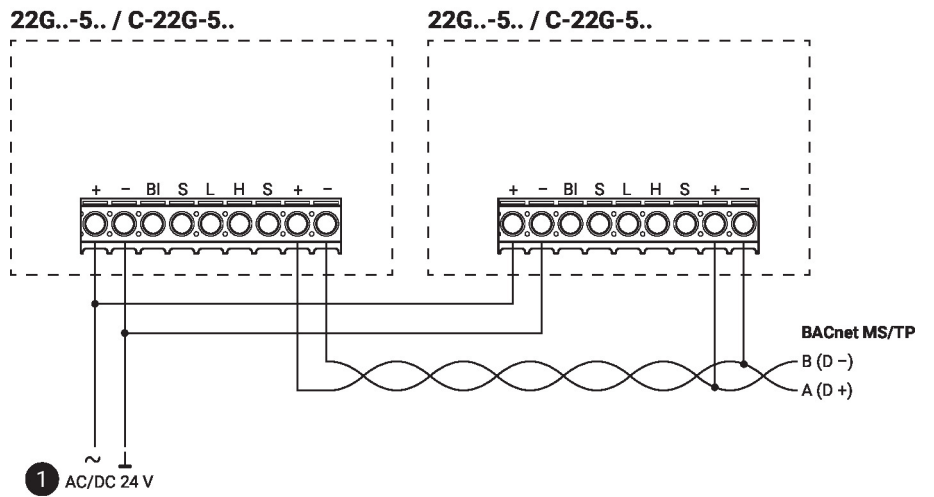

- 1 No connection to the ground

Dimensions

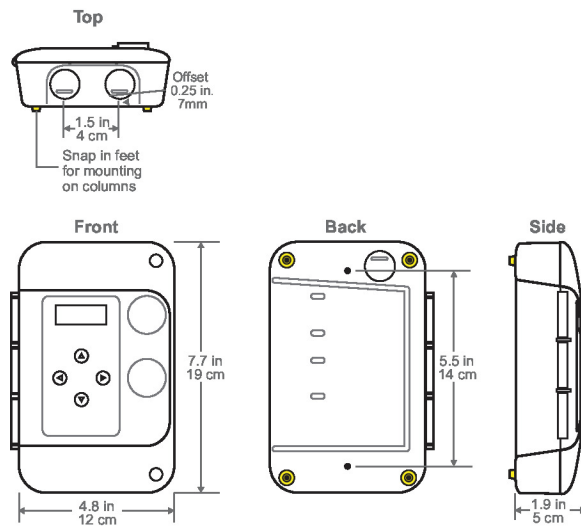

Type

22G15-5A5

22G15-5B5

Weight

0.95 lb [0.43 kg]

0.95 lb [0.43 kg]

Further documentation

- Installation instructions
- Operating instructions