

5-year warranty



Technical data

Electrical Data	Nominal voltage frequency	50/60 Hz
Functional Data	Sensor Technology	Ultrasonic transit time
	Application	water
	Pipe connection	Flange ANSI 250
	Installation position	upright to horizontal
	Servicing	maintenance-free
Measuring Data	Measured values	Flow
	Measuring fluid	Water and water-glycol mixtures
	Measuring principle	Ultrasonic volumetric flow measurement
	Measuring accuracy flow	±2%
	Measurement Repeatability	±0.5% (Flow)
Materials	Fluid wetted parts	Cast iron
	Flow measuring pipe	EN-GJL-250 (GG 25), with protective paint
Safety Data	Ambient humidity	Max. 95% RH, non-condensing
	Protection class IEC/EN	III, Safety Extra-Low Voltage (SELV)
	Power source UL	Class 2 Supply
	Certification IEC/EN	IEC/EN 60730-1:11 and IEC/EN 60730-2-15:10
	UL Approval	cULus acc. to UL94
	UL 2043 Compliant	Suitable for use in air plenums per Section 300.22(C) of the NEC and Section 602 of the IMC
	Degree of protection IEC/EN	IP54
	Degree of protection NEMA/UL	NEMA 2
	Enclosure	UL Enclosure Type 2
	EMC	CE according to 2014/30/EU
	Quality Standard	ISO 9001
	Mode of operation	Type 1
	Pollution degree	3

Safety Notes



This device has been designed for use in stationary heating, ventilation and air-conditioning systems and must not be used outside the specified field of application, especially in aircraft or in any other airborne means of transport.

Outdoor applications: Only possible where (sea) water, snow, ice, sunlight or aggressive gases cannot interfere directly with the device and it can be guaranteed that the ambient conditions remain at all times within the thresholds according to the data sheet.

Only authorized specialists may carry out installation. All applicable legal or institutional installation regulations must be complied during installation.

The device contains electrical and electronic components and must not be disposed of as household refuse. All locally valid regulations and requirements must be observed.

Product Features

Mode of operation The ultrasonic flow sensor is equipped with a flow pipe, four flow transmitters and an electronic circuit. A temperature sensor is mounted in the flow pipe to compensate the temperature effects.

A sensor error occurs when the ultrasonic path is interrupted (air bubbles in the system, connection to ultrasonic transducers interrupted).

Patented glycol compensation Glycol changes the viscosity of the heat transfer fluid and as a result affects the measured volumetric flow. Without glycol compensation, volumetric flow measurements can show errors of as much as 30 percent. The patented automatic glycol compensation significantly reduces the degree of measurement error.

Installation notes

Recommended installation positions The sensor can be installed upright to horizontal. The sensor may not be installed in a hanging position.

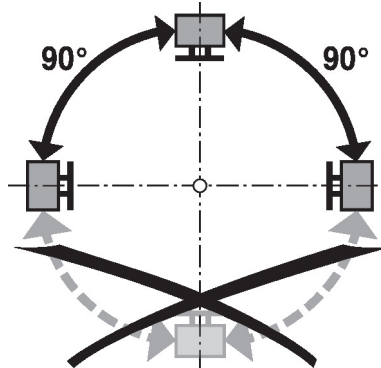

Installation in return Installation in the return is recommended.

Inlet section In order to achieve the specified measuring accuracy, a flow-calming section or inflow section in the direction of the flow is to be provided upstream from the flow sensor. Its dimensions should be at least 5x DN.

Nominal Pipe Size	L min.
2 1/2" (DN 65)	5 x 2 1/2" = 12 1/2"
3" (DN 80)	5 x 3" = 15"
4" (DN 100)	5 x 4" = 20"
5" (DN 125)	5 x 5" = 25"
6" (DN 150)	5 x 6" = 30"

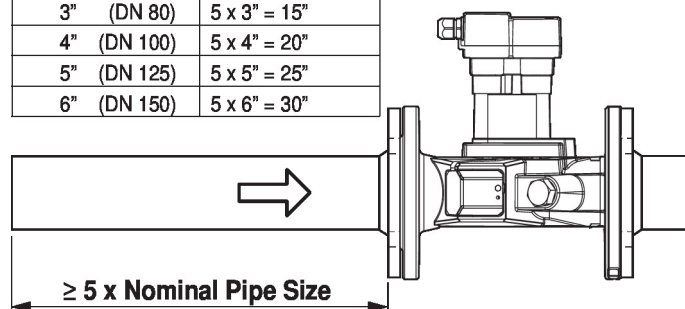

Servicing Sensors are maintenance-free.

Before any service work on the sensor is carried out, it is essential to isolate the sensor from the power supply (by unplugging the electrical cables if necessary). Any pumps in the part of the piping system concerned must also be switched off and the appropriate slide valves closed (allow all components to cool down first if necessary and always reduce the system pressure to ambient pressure level).

The system must not be returned to service until the sensor has been correctly reassembled in accordance with the instructions and the pipeline has been refilled by professionally trained personnel.

Flow direction The direction of flow, specified by an arrow on the housing, is to be complied with, since otherwise the flow rate will be measured incorrectly.