

Basic Fail-Safe actuator for controlling dampers in typical commercial HVAC applications.

- Torque motor 54 in-lb [6 Nm]
- Nominal voltage AC/DC 24 V
- Control On/Off



5-year warranty



Technical data

<b>Electrical data</b>	Nominal voltage	AC/DC 24 V
	Nominal voltage frequency	50/60 Hz
	Nominal voltage range	AC 19.2...28.8 V / DC 21.6...28.8 V
	Power consumption in operation	11 W
	Power consumption in rest position	3 W
	Transformer sizing	22 VA
	Electrical Connection	18 GA plenum cable, 1 m, with 1/2" NPT conduit connector
	Overload Protection	electronic throughout 0...95° rotation
	Electrical Protection	actuators are double insulated
<b>Functional data</b>	Torque motor	54 in-lb [6 Nm]
	Setting Fail-Safe Position	adjustable with dial 0...100% in 10% increments
	Bridging time (PF)	0 s
	Pre-charging time	9...15 s
	Direction of motion motor	selectable with switch 0/1
	Direction of motion fail-safe	reversible with switch
	Manual override	external push button
	Angle of rotation	Max. 95°
	Angle of rotation note	adjustable with mechanical stop
	Running Time (Motor)	4 s / 90°
	Running time motor note	constant, independent of load
	Running time fail-safe	<4 s
	Noise level, motor	60 dB(A)
	Noise level, fail-safe	60 dB(A)
Position indication	Mechanical, 30...65 mm stroke	
<b>Safety data</b>	Power source UL	Class 2 Supply
	Degree of protection IEC/EN	IP54
	Degree of protection NEMA/UL	NEMA 2
	Enclosure	UL Enclosure Type 2
	Agency Listing	cULus acc. to UL60730-1A/-2-14, CAN/CSA E60730-1:02, CE acc. to 2014/30/EU
	Quality Standard	ISO 9001
	UL 2043 Compliant	Suitable for use in air plenums per Section 300.22(C) of the NEC and Section 602 of the IMC
	Ambient humidity	Max. 95% RH, non-condensing
	Ambient temperature	-22...122°F [-30...50°C]
	Storage temperature	-40...176°F [-40...80°C]
	Servicing	maintenance-free

<b>Weight</b>	Weight	4.1 lb [1.9 kg]
<b>Materials</b>	Housing material	UL94-5VA
<b>Footnotes</b>	†Rated Impulse Voltage 800V, Type of action 1.AA, Control Pollution Degree 3	

**Product features**

<b>Application</b>	For On/Off, fail-safe control of dampers in HVAC systems. Actuator sizing should be done in accordance with the damper manufacturer's specifications. Control is On/Off from an auxiliary contact or a manual switch. The actuator is mounted directly to a damper shaft up to 1.05" in diameter by means of its universal clamp. A crank arm and several mounting brackets are available for applications where the actuator cannot be direct coupled to the damper shaft.
<b>Operation</b>	<p>The NKQ..24-1 actuator provides 95° of rotation and a visual indicator shows the position of the actuator. When reaching the damper or actuator end position the actuator automatically stops. The gear can be manually disengaged by pressing the black button located on the actuator cover. The NKQ..24-1 actuators use a brushless DC motor, which is controlled by an Application Specific Integrated Circuit (ASIC). The ASIC monitors and controls the actuators rotation and provides a digital rotation sensing (DRS) function to prevent damage to the actuator in a stall condition. Power consumption is reduced in a holding mode. The actuator is electronically protected against overload. The anti-rotation strap supplied with the actuator will prevent lateral movement. Add-on auxiliary switches or feedback potentiometers are easily fastened directly onto the actuator body for signaling and switching functions.</p> <p>Fail-Safe Indication</p> <p>LED status indicator lights sequence:</p> <p>Yellow off / Green on: operation ok, no faults</p> <p>Yellow off / Green blinking: fail-safe mechanism is active</p> <p>Yellow on / Green off: fault is detected</p> <p>Yellow off / Green off: not in operation / capacitors charging</p> <p>Yellow on / Green on: adaption running</p>
<b>Typical specification</b>	On/Off electrical fail-safe damper actuators shall be electronic direct-coupled type, which require no crank arm and linkage and be capable of direct mounting to a shaft up to 1.05" diameter. Actuators shall have brushless DC motor technology and be protected from overload at all angles of rotation. Actuators shall have reversing switch and manual override on the cover. Run time shall be constant and independent of torque. Actuators shall be cULus listed, have a 5-year warranty, and be manufactured under ISO 9001 International Quality Control Standards. Actuators shall be as manufactured by Belimo.

**Accessories**

Electrical accessories	Description	Type
	Feedback potentiometer 10 kΩ add-on, grey	P10000A GR
	Feedback potentiometer 1 kΩ add-on, grey	P1000A GR
	Feedback potentiometer 140 Ω add-on, grey	P140A GR
	Feedback potentiometer 2.8 kΩ add-on, grey	P2800A GR
	Auxiliary switch, mercury-free	P475
	Auxiliary switch, mercury-free	P475-1
	Feedback potentiometer 5 kΩ add-on, grey	P5000A GR
	Feedback potentiometer 500 Ω add-on, grey	P500A GR
	Signal simulator, Power supply AC 120 V	PS-100
	Auxiliary switch 1x SPDT add-on	S1A
	Auxiliary switch 2x SPDT add-on	S2A
	Cable conduit connector 1/2"	TF-CC US
	Transformer, AC 120 V to AC 24 V, 40 VA	ZG-X40
	Adapter for auxiliary switch and feedback potentiometer	Z-SPA

Mechanical accessories	Description	Type
	Actuator arm for standard shaft clamp (one-sided)	AH-25
	Shaft extension 170 mm ø10 mm for damper shaft ø6...16 mm	AV6-20
	Shaft extension 240 mm ø20 mm for damper shaft ø8...22.7 mm	AV8-25
	Clamp NM/AM 1/2", 3/4", 1"	K-AM25
	Ball joint suitable for damper crank arm KH8	KG8
	Damper crank arm Slot width 8.2 mm, for ø1.05"	KH12
	Damper crank arm Slot width 6.2 mm, clamping range ø10...18 mm	KH6
	Damper crank arm Slot width 8.2 mm, clamping range ø10...18 mm	KH8
	Shaft clamp reversible, clamping range ø10...20 mm	K-SA
	Push rod for KG6 & KG8 ball joints (36" L, 5/16" diameter).	SH8
	Anti-rotation bracket TF/NKQ/AM/NM/LM.	TF-P
	Wrench 0.32 in and 0.39 in [8 mm and 10 mm]	TOOL-06
	Mounting bracket for AF..	ZG-100
	Mounting bracket	ZG-101
	Mounting bracket	ZG-103
	Mounting bracket	ZG-104
	Damper clip for damper blade, 3.5" width.	ZG-DC1
	Damper clip for damper blade, 6" width.	ZG-DC2
	1" diameter jackshaft adaptor (11" L).	ZG-JSA-1
	1-5/16" diameter jackshaft adaptor (12" L).	ZG-JSA-2
	1.05" diameter jackshaft adaptor (12" L).	ZG-JSA-3
	Mounting kit for linkage operation for flat installation	ZG-NMA
	Shaft extension for 1/2" diameter shafts (3.8" L).	ZG-NMSA-1
	Weather shield 13x8x6" [330x203x152 mm] (LxWxH)	ZS-100
	Baseplate, for ZS-100	ZS-101
	Weather shield 406x213x102 mm [16x8-3/8x4"] (LxWxH)	ZS-150
	Jackshaft mounting bracket.	ZG-120

**Electrical installation**
**⚠ Warning! Live electrical components!**

During installation, testing, servicing and troubleshooting of this product, it may be necessary to work with live electrical components. Have a qualified licensed electrician or other individual who has been properly trained in handling live electrical components perform these tasks. Failure to follow all electrical safety precautions when exposed to live electrical components could result in death or serious injury.

◆ Meets cULus requirements without the need of an electrical ground connection.

⚠1 Provide overload protection and disconnect as required.

⚠3 Actuators may also be powered by DC 24 V.

⚠11 Actuators may be connected in parallel if not mechanically linked. Power consumption and input impedance must be observed.

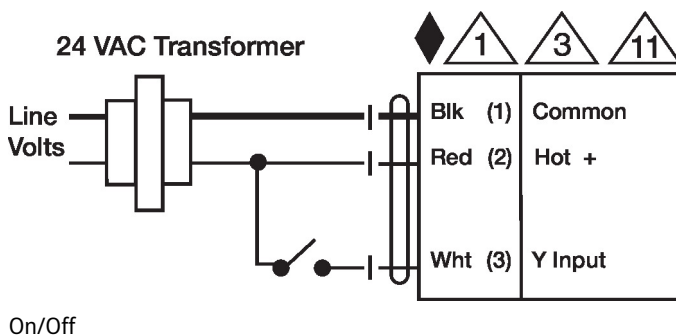

## Dimensions

