

# EXT Potable Water Butterfly Valves

## EXT-141..

### Potable Water Butterfly Valves

#### Technical Data

Media	domestic potable water
Flow characteristic	modified equal percentage
Controllable flow range	90°
Sizes	2", 3", 4", 5", 6", 8", 10"
Materials:	
Body	ductile iron ASTM A536
Body finish	black epoxy powder coating
Disc	Aluminum bronze
Seat	EPDM
Shaft	416 stainless steel
Bushings	glass reinforced epoxy resin
Media temp. range	-22...250°F [-30...120°C]
Body pressure rating	200 psi
Close-off pressure	150 psi
Maximum velocity	12 FPS
Leakage	0%
Warranty	2 years
CRN	0C12102.*CL

#### Valve Installation Procedure

Position the connecting pipe flanges in the line to insure proper alignment prior to valve installation. Spread the pipe flanges apart enough to allow the valve body to be located between the flanges without actually contacting the flange surfaces. Exercise particular care in handling the valve so as to prevent possible damage to the disc or seat faces.

- EXT Series Butterfly valves are designed to be installed between ANSI 125/150 flat-faced, raised face, slip-on or weld neck flanges.
- Do NOT use flange gaskets on EXT Series Butterfly valves.
- For Lug style valves:
  - Place the valve between the flanges.
  - Install all bolts between the valve and the mating flanges. Hand tighten bolts as necessary.
- Using the sequence, tighten the flange bolts evenly to assure uniform compression. Make multiple tightening rounds, 1st to 30%, 60%, then 100%. In assembling flange joints, the resilient seating surface shall be uniformly compressed. A small gap may be present if max torque is reached. Do not over tighten bolts or liner damage, liner shifting or stripping may occur.
- Before completing the tightening of any bolts, the valve should be centered between the flanges and then carefully opened and closed to insure free, unobstructed disc movement.

#### Installation Recommendations

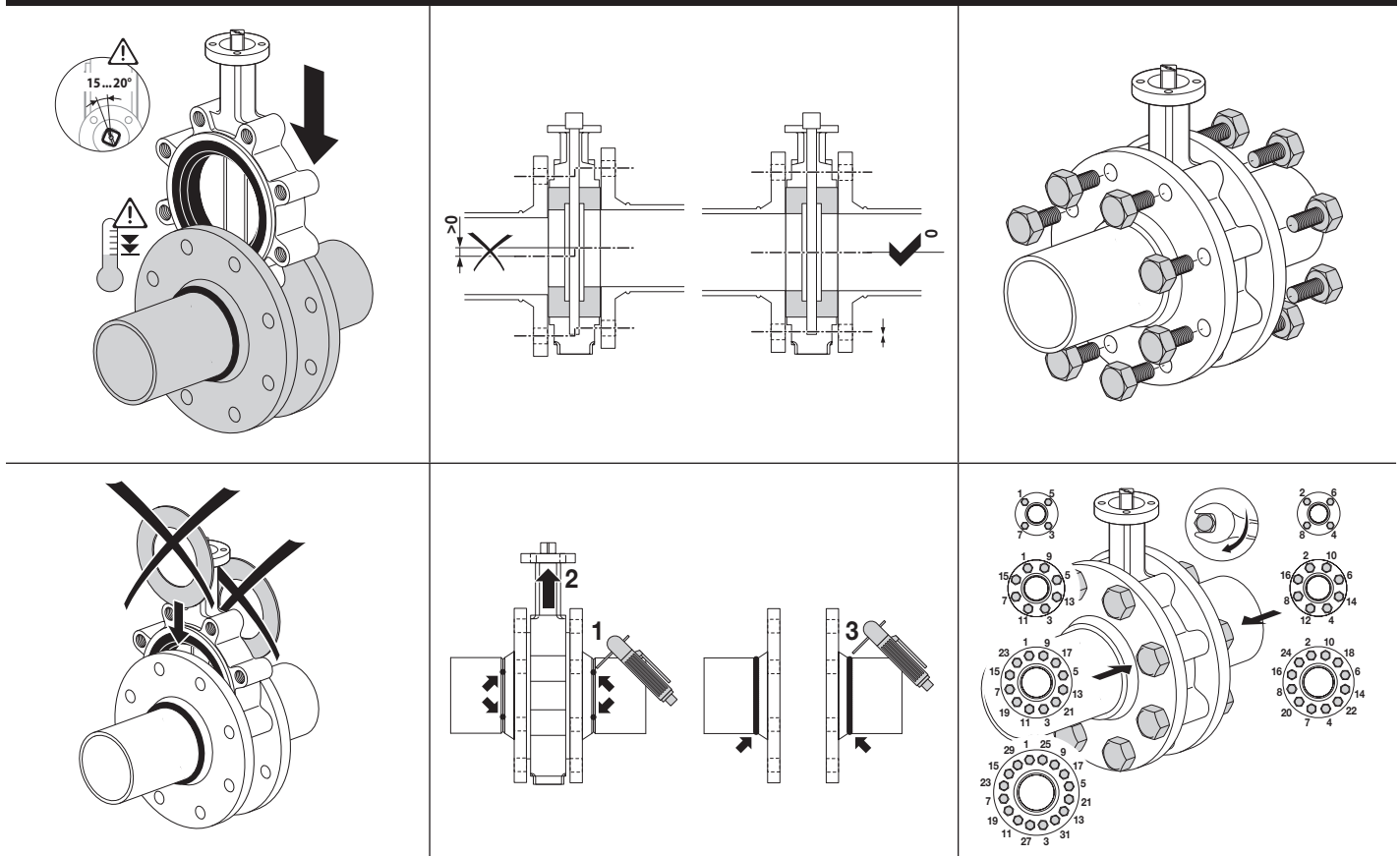

### Max Torque for Bolts

Valve Size	Bolt Size	Max Torque [ft-lbs]
2...4"	5/8"	70, ±5%
5...8"	3/4"	120, ±5%
10...12"	7/8"	200, ±5%

### Valve Installation Procedure Continued

- Valve should be installed a minimum of 6 pipe diameters from upstream or downstream elbows, strainers, pumps, etc. If not practical due to space constraints, the system should be designed to locate and orient the valve to minimize the impact of dynamic torque on valve life.

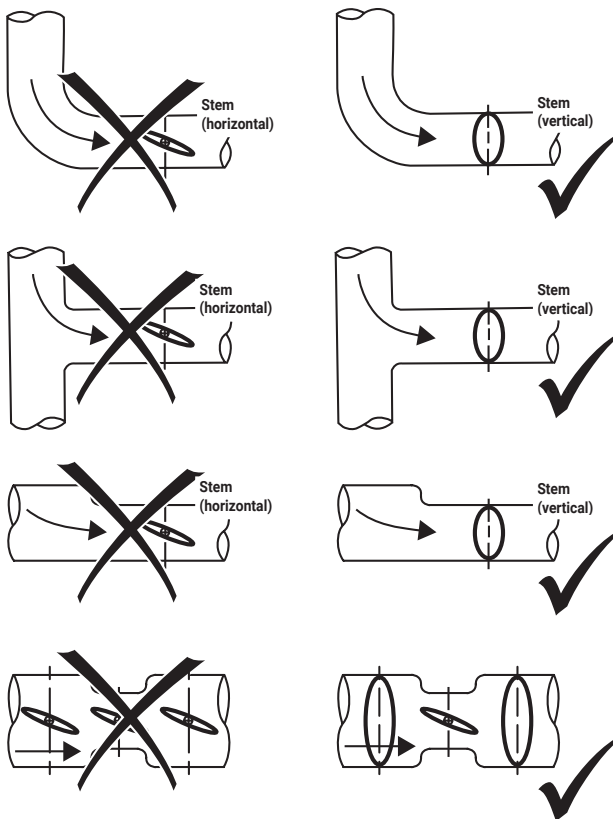

- If an actuator is to be operated, electricity should be connected to the unit in accordance with the local electrical codes.
- Cycle the valve to the fully open position, then back to the fully closed position, checking the actuator travel stop settings for proper disc alignment. The valve should be operated to assure that no binding is taking place. If no power is available, use the manual handwheel.
- The valve is now ready for operation.

### General Maintenance

The following periodic preventative maintenance practices are recommended for all Butterfly Valves.

- Operate the valve from full open to full closed to assure operability.
- Check flange bolting, actuator mounts and hangers for evidence of loosening and correct as needed.
- Inspect the valve and surrounding area for previous or existing leakage at flange faces or shaft connections.
- Check piping and/or wiring to actuators and related equipment for looseness and correct as needed.
- If not in use, exercise the butterfly valve (full open and close) at least once a month.

**Note:** Run an adaptation when a new MFT actuator is installed.

### Safety Precautions

Before removing the valve from the line or loosening any bolts, it is important to verify the following conditions:

- Be sure the line is depressurized and drained.
- Be sure of the pipeline media. Proper care should be taken for protection against toxic and/or flammable fluids.
- Never remove the valve without an Operator (Manual or Automatic) already attached to the valve shaft.
- Never remove the Operator from the valve while the valve is in the pipeline under pressure.
- Always be sure that the disc is cracked approximately 5° off of the closed position before removing the valve.

### Storage of Butterfly Valve Assemblies

- Assemblies must be stored indoors, protected from the elements.
- Materials received on job sites that have long installation lead times should receive extra protection from construction damage.
- Valve faces must be protected from abrasion, cutting and nicking, as this will damage the face and may cause flange area leaks.
- Electric actuators cannot be stored in wet, damp or caustic areas.
- Do not store construction material on top of valve assemblies.

### Valve Installation- Dead End Service

#### INSTALLATION NOTES

- Follow previously described pre-installation and installation procedures.
- To achieve the full close-off pressure of the EXT Series, a flange is required on the open or down stream side of the valve (See diagram below)

