

BACnet MSTP /  
Modbus RTU

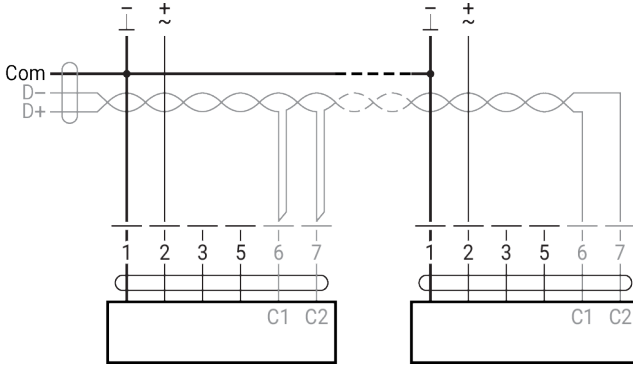

MP-Bus

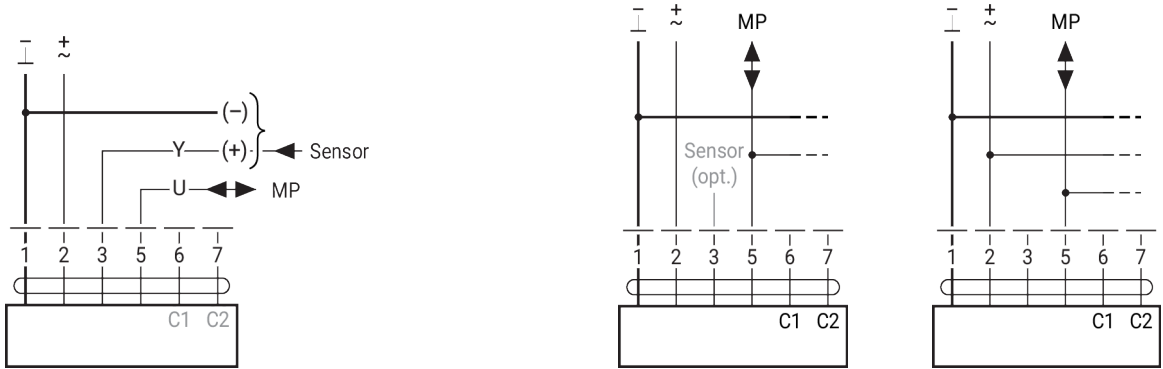

Sensor (optional)

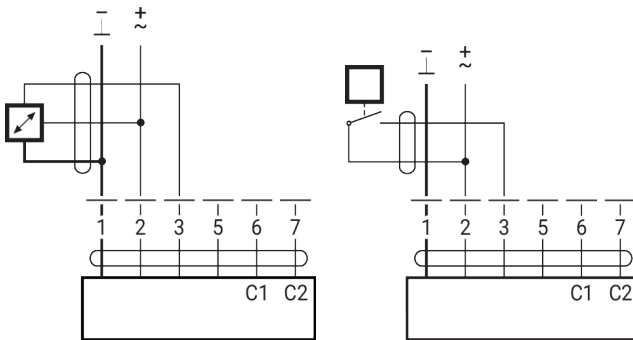

## Inlet Section

DN	L min.
65	5 x 65 mm = 325 mm
80	5 x 80 mm = 400 mm
100	5 x 100 mm = 500 mm
125	5 x 125 mm = 625 mm
150	5 x 150 mm = 750 mm

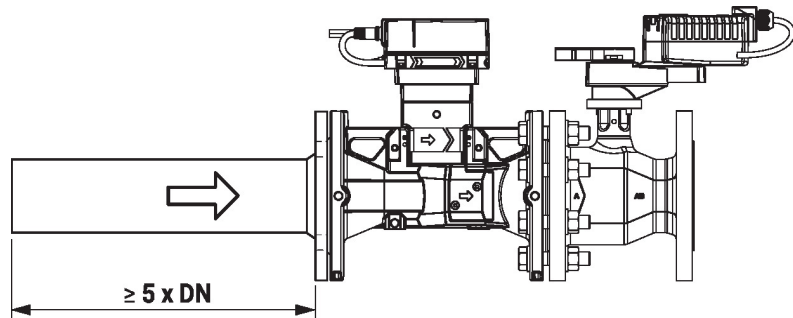

## Piping

The EPIV is recommended to be installed on the return side of the coil. Consult engineering specification and drawings for particular circumstances. P/T ports are recommended on either side of the valve for pressure measurement. Refer to Belimo documentation for flow verification and commissioning procedures. To achieve flows larger than  $V_{nom}$  or nominal flow, it is recommended to connect two valves in parallel leading to a common manifold. It is recommended to use the same signal in parallel (2-10 VDC); the two actuators are wired from the same control signal and the two valves control the flow in an identical pattern, the resulting flow will be the double controlled by an individual valve. This arrangement is preferable to a split signal since it offers a more stable and accurate flow and feedback signal is easier to interpret.

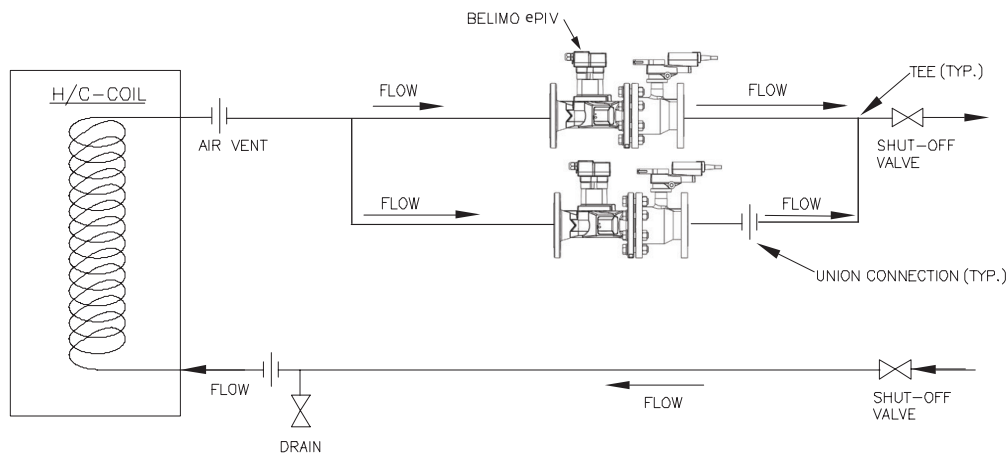

### General Warnings

**Valve should not be used for combustible gas applications. Gas leaks and explosions may result. Do not install in systems, which exceed the ratings of the valve.**

- Avoid installations where valve may be exposed to excessive moisture, corrosive fumes, vibration, high ambient temperatures, elements, or high traffic areas with potential for mechanical damage.
- Valve assembly location must be within ambient ratings of actuator. If temperature is below  $-14^{\circ}\text{F}$  a heater is required.
- The valve assembly will require heat shielding, thermal isolation, or cooling if combined effect of medium and ambient temperatures – conduction, convection, and radiation – is above  $122^{\circ}\text{F}$  for prolonged time periods at the actuator.
- Visual access must be provided. Assembly must be accessible for routine schedule service. Contractor should provide unions for removal from line and isolation valves.
- Avoid excessive stresses. Mechanical support must be provided where reducers have been used and the piping system may have less structural integrity than full pipe sizes.
- Sufficient upstream piping runs must be provided to ensure proper valve capacity and flow response. See installation section for details.

### Installation

1. Inspect shipping package, valve, linkage, and actuator for physical damage. If shipping damage has occurred notify appropriate carrier. Do not install.
2. If a replacement, remove existing valve, linkage, and actuator from the piping system.
3. If actuator and linkage are removed, they must be reinstalled correctly. The actuator must be rotated so that the valve seats properly for close off.
4. Install valve with the proper ports as inlets and outlets. Check that inlet and outlet of 2-way valves are correct. Flow direction arrows must be correct.
5. Blow out all piping and thoroughly clean before valve installation.
6. Clean flanges with wire brush and rag. Clean pipes, flanges, and valve flanges before installation; check for any foreign material that can become lodged in trim components. Strainers should be cleaned after initial startup.
7. Valve must be installed with the stem towards the vertical, not below horizontal.
8. -125 models are designed to be installed between ANSI Class 125/150 flanges only. -250 models are designed to be installed between ANSI Class 250/300 flanges only.
9. Carefully follow installation using ANSI piping practices.