

71362-00001.B

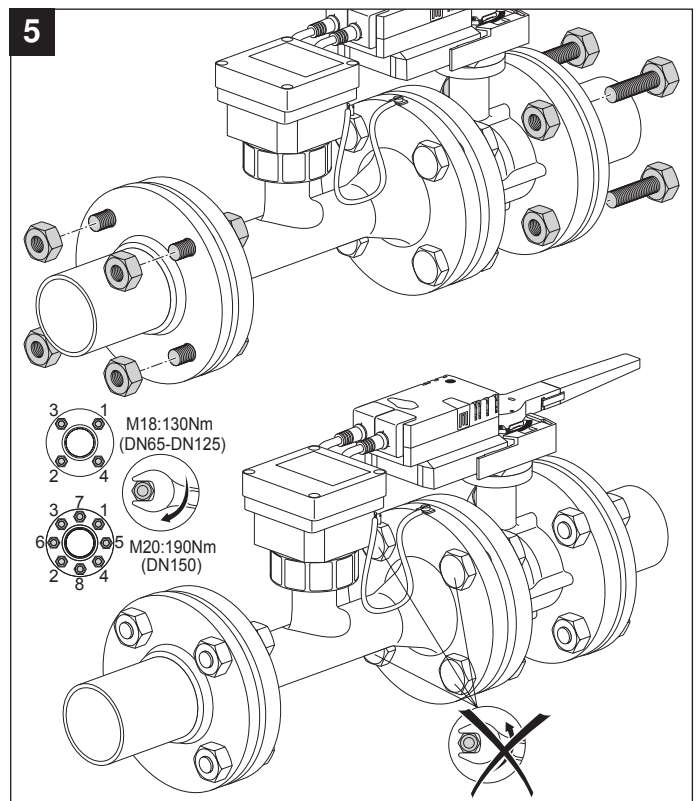

* : Welding machine can be used if the flanges of the piping need to be mounted in this way directly at the job site when install the EV system.

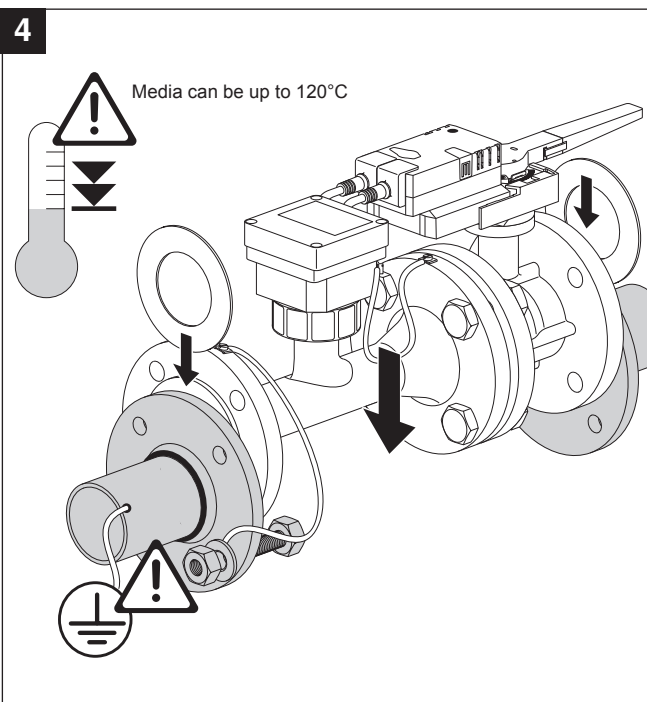
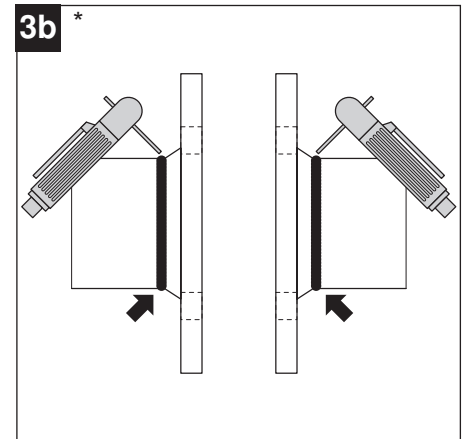
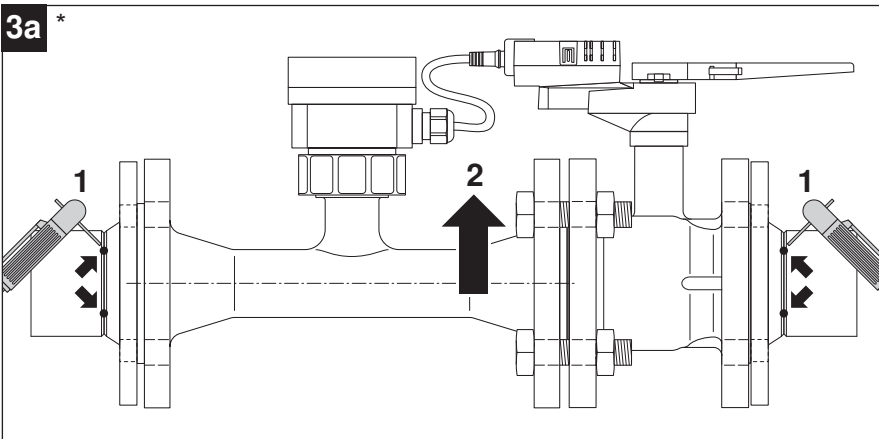
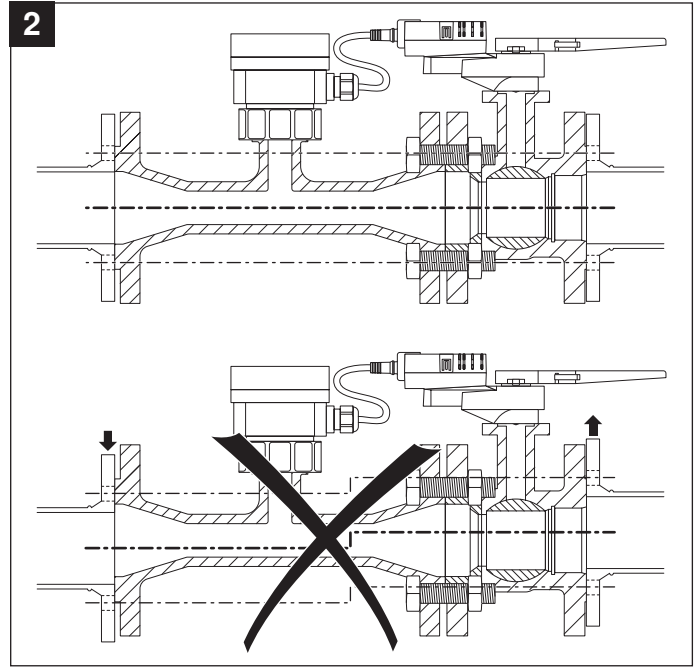
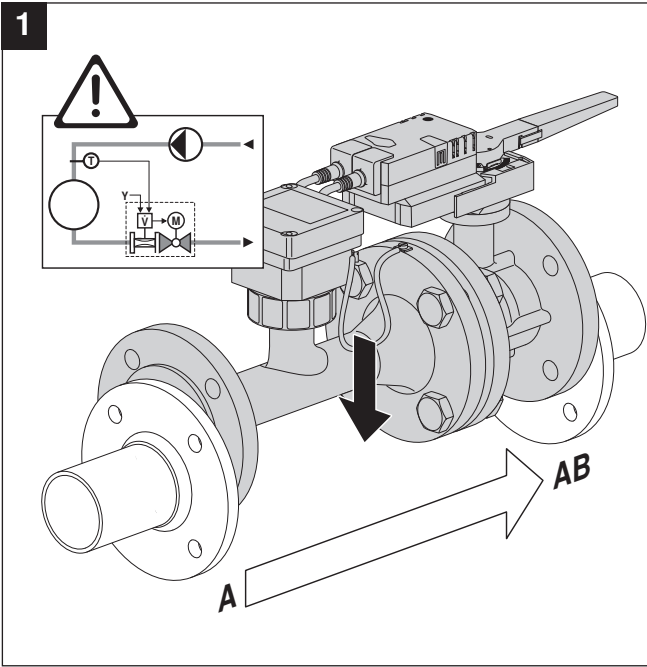
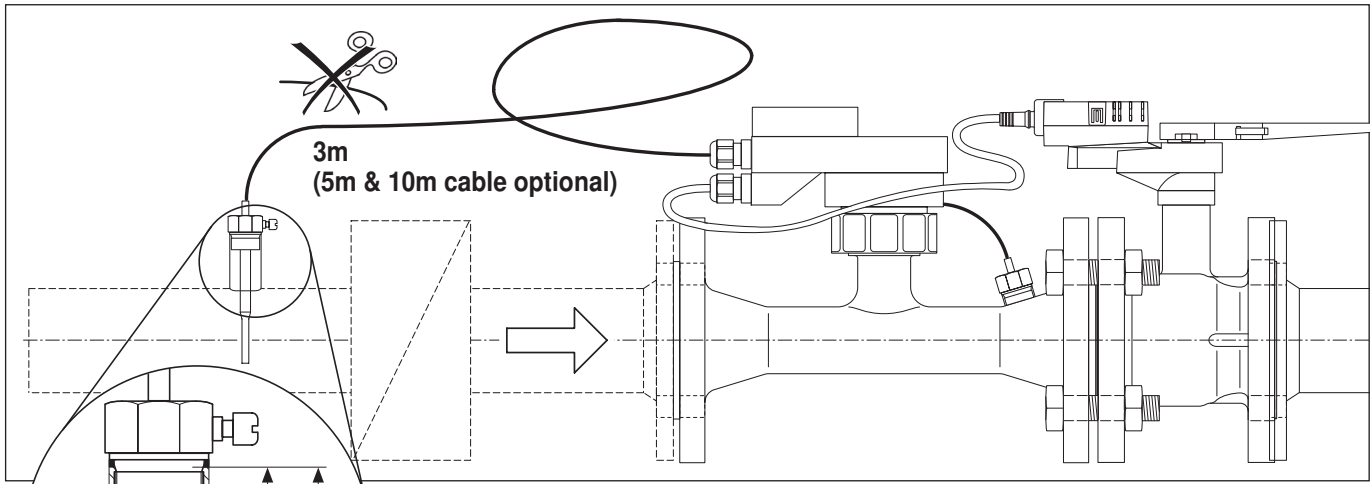

DN	L 1)	G	LT
65 ... 400	≤30 mm	1/2"	≥15 mm

1) DN 65 = 30 mm

