

# GM and GK Series NEMA 4, UL Type 4 Mounting Installation Instructions



## General Information

Protection: NEMA 4, UL Type 4, IP66

UV protected housing

Weather-tight for the harshest indoor and outdoor conditions

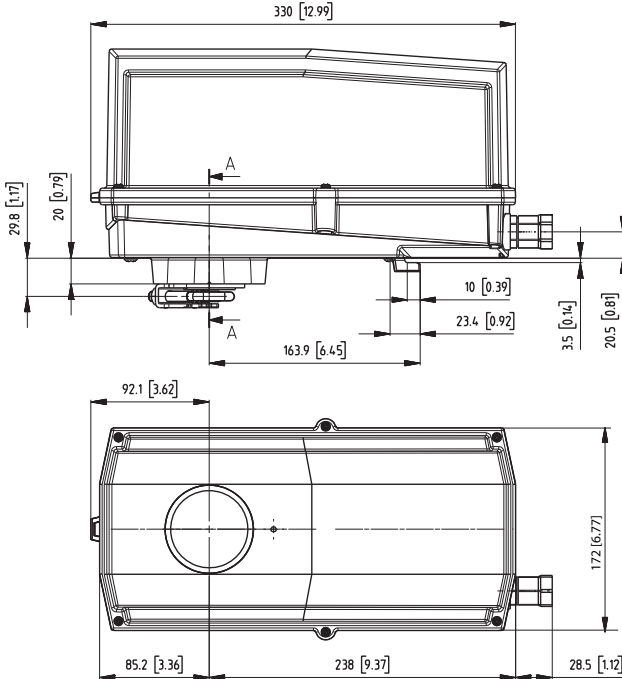

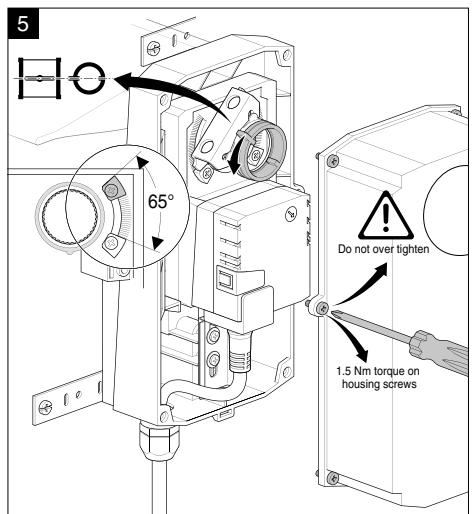
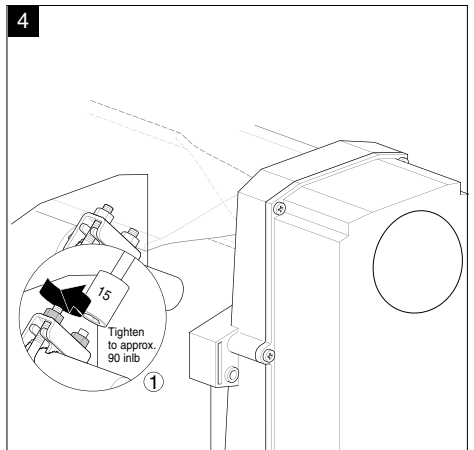
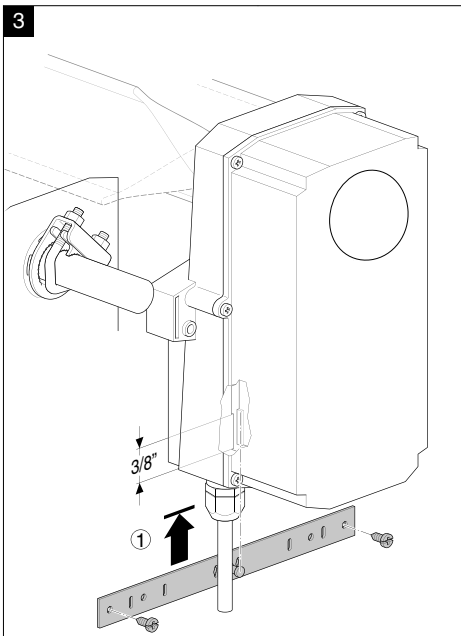
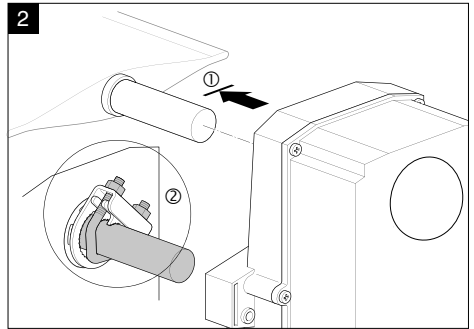
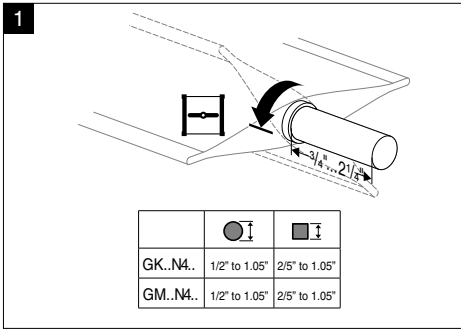

## Standard Mounting

1. Remove the housing cover. Turn the damper shaft until the blades are fully closed
2. (1) Slip the actuator's universal clamp over the damper shaft. Make sure that the duct and the controls on the cover are accessible. Place the actuator in the desired mounting position.  
(2) Hand tighten the two nuts on the actuators universal clamp.
3. Disengage the actuator gear train by pressing the manual override button on the actuator.  
(1) Slide the anti-rotation bracket up under the actuator so it engages the actuator at the center of the cutout. Bend the bracket as needed to support the rear of the actuator. Secure to duct work with self-tapping screws (No. 8 recommended).
4. Loosen the nuts on the universal clamp.  
Press the manual override button on the actuator and rotate clamp about 5° from the closed position (1/16" to 1/8" between stop and clamp).  
(1) Tighten the two nuts on the universal clamp with a 13 mm wrench. Do not over tighten.
5. Install the cover. The damper is now fully closed but the actuator is 5° from fully closed. This is called "pre-loading" the actuator. When the actuator is powered and sent to the closed position, it will put its full torque on the shaft compressing the edge and blade seals. This ensures that the damper will meet its leakage rating. The actuator is electronically protected from overload and will not be damaged.

## Testing the installation without power

1. Disengage the gear train with the manual override button and move the shaft from closed to open to closed. Stroking the damper from fully open to close, with 5° of actuator stroke left, ensures there is no binding.
2. Correct any problems and reset.

## NOTES:

Ambient temperature: -22°F to 122°F [-30°C to 50°C]

Storage temperature: -40°F to 176°F [-40°C to 80°C]

These actuators are intended to be connected in the field by a flexible metal conduit except when provided with listed cables suitable for NEMA type 4 application.

These devices are not suitable for plenum applications.

Airside Product	Power Supply	Power Consumption	Feedback	
	24 VAC $\pm 20\%$ , VDC $\pm 15\%$	VA Rating	Wattage running (holding)	Position Feedback
GKB(X)24-3-T N4	•	21	12 (3)	N/A
GMB(X)24-3-T N4	•	6	4 (2)	N/A

Wiring

GM

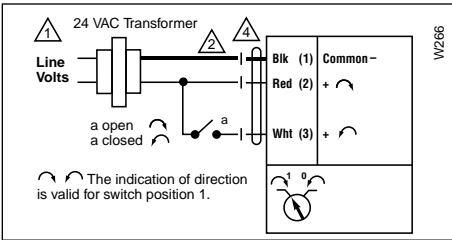

On/Off

GM

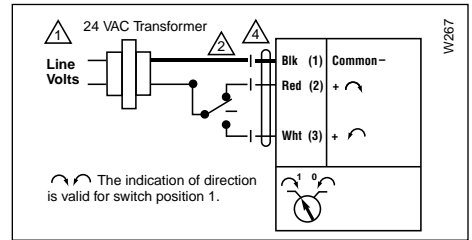

Floating Point or On/Off control

Notes:

- 1 Provide overload protection and disconnect as required.
- 2 Actuators may also be powered by 24 VDC for a 24V power supply.
- 4 Meets cULus requirements without the need of an electrical ground connection.

GK

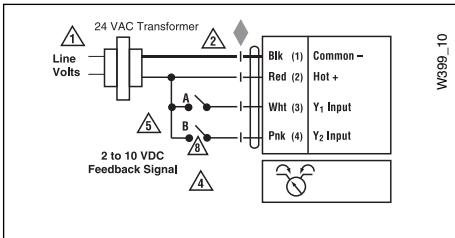

Floating Point or On/Off control

Notes:

- 1 Provide overload protection and disconnect as required.
- 2 Actuators may also be powered by 24 VDC for a 24V power supply.
- 4 Meets cULus requirements without the need of an electrical ground connection.
- 5 For 100 to 240 VAC no transformer is required.
- 8 Contact closures A & B also can be triacs. A & B should both be closed for triac source and open for triac sink.

Airside Product	Torque (based on 4 in-lb per sq. ft)						Feedback
	Fail-Safe Running Time	Running Time	Power Supply	Power Consumption	Feedback		
GKB(X)24-SR-T N4	35	360 in-lb [40 Nm] Approx. 90 sq. ft.	Motor Drive (Default)	24 VAC $\pm 20\%$ , VDC $\pm 15\%$	VA Rating	Wattage running (holding)	Position Feedback 2-10 VDC
GMB(X)24-SR-T N4	N/A	•	150	•	6.5	12 (3) 4.5 (2)	•

## Wiring

### VDC/4-20 mA

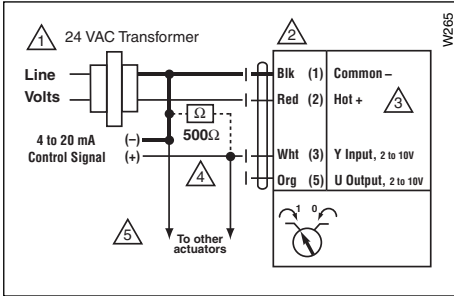

#### Notes:

- 1 Provide overload protection and disconnect as required.
- 2 Actuators may be connected in parallel. Power consumption and input impedance must be observed.
- 3 Actuators may also be powered by 24 VDC.
- 4 The ZG-R01 500  $\Omega$  resistor converts the 4 to 20 mA control signal to 2 to 10 VDC, up to 2 actuators may be connected in parallel.
- 5 Only connect common to neg. (-) leg of control circuits.

Airside Product	Torque (based on 4 in-lb per sq. ft)							
	Fail-Safe Running Time	Running Time	Power Supply	Power Consumption	Feedback	Motor Drive (seconds)	Wattage Running (holding)	VDC Variable (0 to 10 VDC)
GKX24-MFT-T N4	35	•	150	•	21	12 (3)	•	•
GMX24-MFT-T N4	N/A	•	150	•	7	4 (1.5)	•	•

Wiring

### VDC/4-20 mA

### Floating Point

### PWM

### On/Off

### Notes:

- 1 Provide overload protection and disconnect as required.
- 2 Actuators may be connected in parallel if not mechanically mounted to the same shaft. Power consumption and input impedance must be observed.
- 3 Actuators may also be powered by 24 VDC.3
- 4 Position feedback cannot be used with a Triac sink controller. The actuator internal common reference is not compatible.
- 6 Control signal may be pulsed from either the Hot (Source) or Common (Sink) 24 VAC line.
- 7 ZG-R01 may be used.
- 8 Contact closures A & B also can be triacs. A & B should both be closed for triac source and open for triac sink.
- 9 For triac sink the common connection from the actuator must be connected to the hot connection of the controller.

W-999



Belimo worldwide: [www.belimo.com](http://www.belimo.com)

**BELIMO Americas**

**USA Locations**, 43 Old Ridgebury Road, Danbury, CT 06810

Tel. 800-543-9038, Fax 800-228-8283, [marketing@us.belimo.com](mailto:marketing@us.belimo.com)

1049 Fortunado Loop, Sparks, NV 89436

Tel. 800-987-9042, Fax 800-987-8875, [marketing@us.belimo.com](mailto:marketing@us.belimo.com)

**Canada Locations**, 14/16 – 5716 Coopers Avenue, Mississauga, Ontario L4Z 2E8

Tel. 800-805-7089, Fax 905-712-3124, [marketing@us.belimo.com](mailto:marketing@us.belimo.com)

**Latin America and The Carribean Customer Service**,

Tel. 203-791-8396, Fax 203-791-9139, [marketing@us.belimo.com](mailto:marketing@us.belimo.com)

