

ECON-ZIP-LF1

Mounting Installation Instructions

ECON-ZIP-TF1 kit includes:

- One (1) "L" shaped mounting bracket
- Hardware:
 - Three (3) pan head self-drilling screws 4, 2x13
 - Two (2) 1/4-28 X 3 hex heads
 - Two (2) 1/4-28 nylon lock nut
- One (1) ECON-ZIP-ACT kit
 - Kit includes:
 - One (1) shaft adapter
 - One (1) instruction sheet
 - Hardware:
 - Four (4) nut #6-32 Zinc finish NM grade 2 nylon
 - Four (4) screws #6-32 UNCx1/2" Philips pan head
- One (1) instruction sheet

1 Verify that you have all the parts listed before installing the linkage.

2 Remove the Honeywell Black Box Motor (M7XXX) or comparable actuator, without adjusting the current damper linkage assembly.

3 The Mounting Bracket is provided with the hole patterns to mount the LF series actuator in either a horizontal or vertical position to meet space requirements. Mount the bracket to the holes utilizing the three pan head self-drilling screws 4, 2x13.

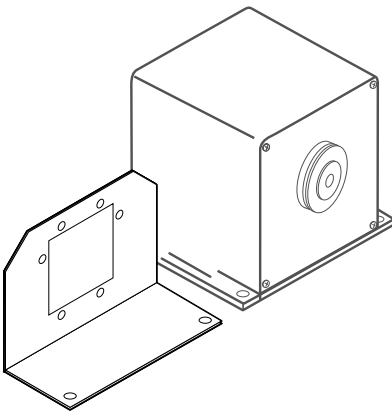

4 Match the hole pattern of the shaft face to the existing linkage and utilize the #6-32 screws and nuts with the ECON-ZIP-ACT to secure into place. **Note: At least 2 screws and nuts should be used.**

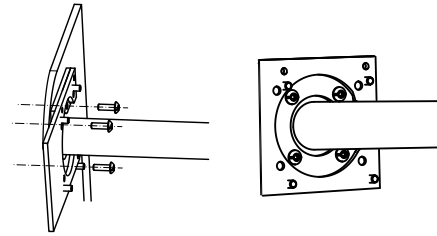

5 Slide the actuator onto the shaft, Secure the actuator to the mounting plate with the two 1/4-28 screws and nuts provided.

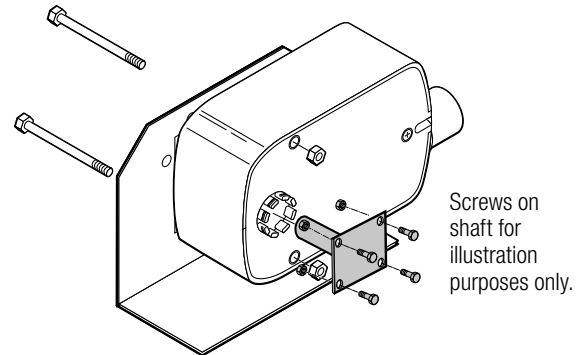

6 Secure the shaft by tightening the nuts on the V-bolt with a 10mm wrench to 6-8 ft-lb of torque.

