

G215S-F Technical Data Sheet



Technical Data

Fluid	chilled or hot water, up to 60% glycol, steam
Flow characteristic	modified equal percentage
Controllable flow range	stem up - open A – AB
Valve Size [mm]	0.5" [15]
Pipe connection	NPT female ends
Housing	Bronze
Stem	316 stainless steel
Stem seal	EPDM O-ring
Seat	Stainless steel AISI 316
Valve plug	316 stainless steel
Body Pressure Rating	ANSI Class 250, up to 400 psi below 150°F
ANSI Class	250
Maximum Inlet Pressure (Steam)	100 psi [690 kPa]
Max Differential Pressure (Steam)	50 psi [345 kPa]
Maximum differential pressure (water)	50 psi (345 kPa)
Rangeability Sv	100:1
Cv	1.3
Weight	2.2 lb [1.0 kg]
Fluid Temp Range (water)	20...338°F [-7...170°C]
Leakage rate	ANSI Class VI
Servicing	repack kits available

Flow/Mounting Details

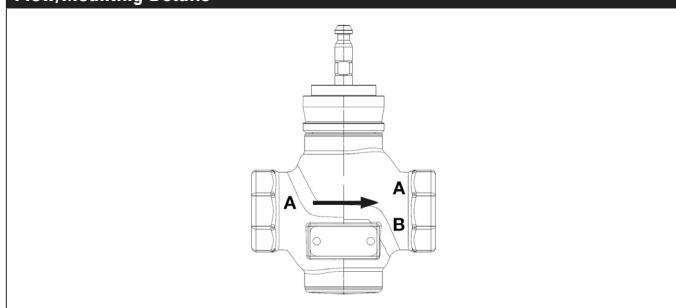

Application

This valve is typically used in air handling units on heating or cooling coils, and fan coil unit heating or cooling coils. Some other common applications include unit ventilators, VAV box re-heat coils and bypass loops. This valve is suitable for use in hydronic systems with variable flow. Bronze and stainless steel trim valves can be used for steam applications, depending on actuator and close-off combinations.

Suitable Actuators

	Non-Spring	Spring	Electronic fail-safe
G215S-F	LVB(X)	LF	LVKB(X)

Dimensions (Inches [mm])

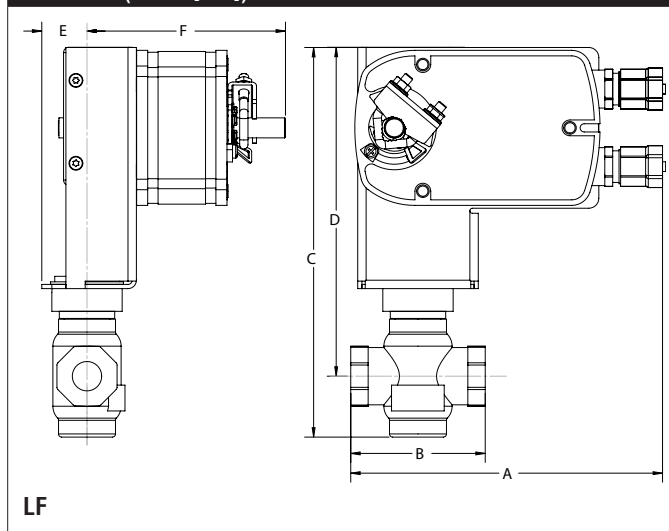

A	B	C	D	E	F
7.9" [200]	3.4" [86]	9.7" [247]	8.2" [208]	1.2" [30]	4.9" [125]

Safety Notes

WARNING: This product can expose you to lead which is known to the State of California to cause cancer and reproductive harm. For more information go to www.p65warnings.ca.gov

Piping

The valves should be mounted in a weather-protected area in a location that is within the ambient limits of the actuator. Allow sufficient room for valve with actuator and for service. The G2 and G3 preferred mounting position of the valve is with the valve stem vertical above the valve body, for maximum life. However, the assemblies can be mounted with the valve stem vertical or horizontal in relation to the pipe. The actuators should never be mounted underneath the valve, as condensation can build up and result in a failure of the actuators.

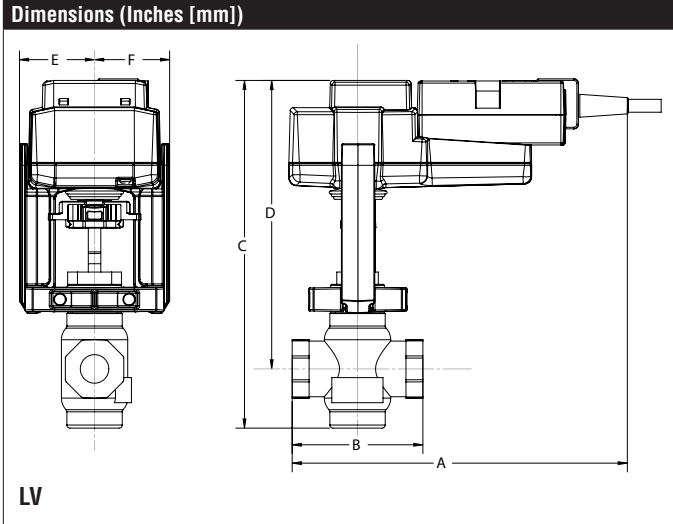

A	B	C	D	E	F
8.6" [218]	3.4" [86]	8.9" [226]	7.4" [188]	1.9" [48]	

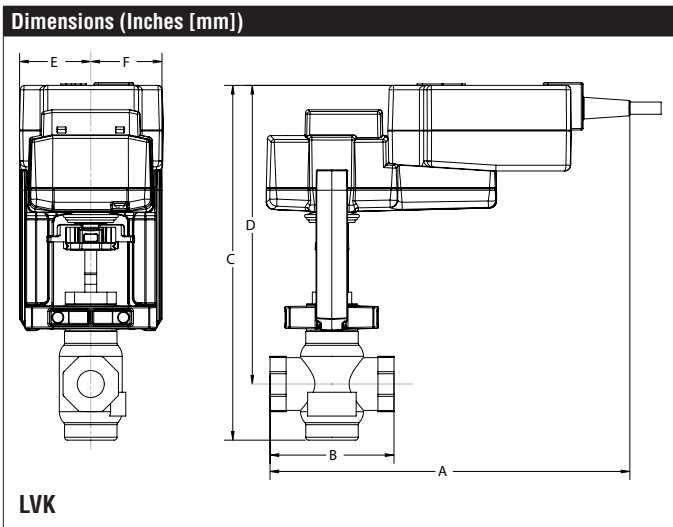

A	B	C	D	E	F
9.7" [246]	3.4" [86]	9.6" [244]	8.1" [206]	1.9" [48]	

LF24-SR US, Valve Actuator Technical Data Sheet

Modulating, Spring Return, AC 24 V for DC 2...10 V or 4...20 mA Control Signal



5-year warranty



Technical Data	
Power Supply	24 VAC, ±20%, 50/60 Hz, 24 VDC, ±10%
Power consumption in operation	2.5 W
Power consumption in rest position	1 W
Transformer sizing	5 VA (class 2 power source)
Electrical Connection	18 GA plenum cable, 3 ft [1 m], with 1/2" conduit connector
Overload Protection	electronic throughout 0...95° rotation
Operating Range	2...10 V, 4...20 mA w/ ZG-R01 (500 Ω, 1/4 W resistor)
Input Impedance	100 kΩ for 2...10 V (0.1 mA), 500 Ω for 4...20 mA
Position Feedback	2...10 V, Max. 0.7 mA
Angle of rotation	90°
Direction of motion motor	selectable with switch 0/1
Direction of motion fail-safe	reversible with cw/ccw mounting
Position indication	Mechanical
Running Time (Motor)	150 s constant, independent of load
Running time fail-safe	<25 s @ -4...122°F [-20...50°C], <60 s @ -22°F [-30°C]
Ambient humidity	max. 95% r.H., non-condensing
Ambient temperature	-22...122°F [-30...50°C]
Storage temperature	-40...176°F [-40...80°C]
Degree of Protection	IP54, NEMA 2
Agency Listing	cULus acc. To UL 873 and CAN/CSA C22.2 No. 24-93
Noise level, motor	50 dB(A)
Noise level, fail-safe	62 dB(A)
Servicing	maintenance-free
Quality Standard	ISO 9001
Weight	3.1 lbs (1.40 kg.)

†Rated Impulse Voltage 800V, Type of action 1.AA, Control Pollution Degree 3

Date created, 12/20/2019 - Subject to change. © Belimo Aircontrols (USA), Inc.

Wiring Diagrams

✂ INSTALLATION NOTES

- A Actuators with appliance cables are numbered.
- 1 Provide overload protection and disconnect as required.
- 3 Actuators may also be powered by 24 VDC.
- 5 Only connect common to negative (-) leg of control circuits.
- 7 A 500 Ω resistor (ZG-R01) converts the 4 to 20 mA control signal to 2 to 10 VDC.
- 11 Actuators may be connected in parallel if not mechanically linked. Power consumption and input impedance must be observed.
- Meets cULus requirements without the need of an electrical ground connection.

⚠ WARNING! LIVE ELECTRICAL COMPONENTS!
 During installation, testing, servicing and troubleshooting of this product, it may be necessary to work with live electrical components. Have a qualified licensed electrician or other individual who has been properly trained in handling live electrical components perform these tasks. Failure to follow all electrical safety precautions when exposed to live electrical components could result in death or serious injury.

