

Z2050QS-J, 1/2", ZoneTight Valve



Technical Data

Media	chilled, hot water, up to 60% glycol
Flow characteristic	equal percentage
Controllable flow range	75°
Valve Size [mm]	0.5" [15]
Pipe connection	sweat
Housing	forged brass
Ball	chrome plated brass
Stem	brass
Seat	Teflon® PTFE
O-ring	EPDM (lubricated)
Body Pressure Rating	360 psi
Maximum Allowable Operating Temperature	212°F [100°C] *
Close-Off Pressure	75 psi
Cv	5.9
Weight	0.22 lb [0.10 kg]
Media Temp Range (water)	36...212°F [2...100°C]
Leakage rate	0%
Maintenance	maintenance free

* If temperature exceeds 212°F operating range due to a boiler control failure the valve will safely contain the hot water but manufacturers product warranty becomes invalid. Valve and actuator replacement is at the expense of others.

Application

The QCV zone valves are suited for large commercial buildings where higher close-off and the ability to change flow is desired. Common applications include unit ventilators, fan coil units, VAV reheat coils, fin tube casing, radiant panels and duct coils. The valve fits in space restricted areas and can be assembled without the use of tools.

Suitable Actuators

	Non-Spring	Electronic fail-safe
Z2050QS-J	CQ	CQK

Dimensions (Inches [mm])

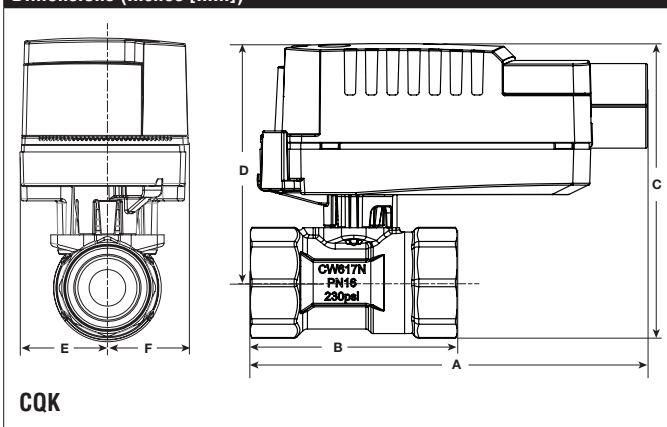

A	B	C	D	E	F
4.5" [114]	2.05" [52]	3.27" [83]	2.71" [69]	0.94" [23.88]	0.94" [24]

Safety Notes

⚠ WARNING: For Belimo Products sold in California, these Products do or may contain chemicals which are known to the State of California to cause cancer and or birth defects or other reproductive harms. For more information see www.p65warnings.ca.gov.

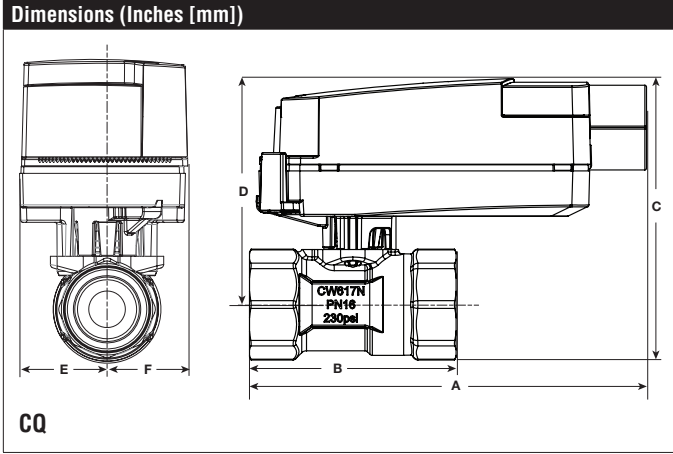

A	B	C	D	E	F
4.5" [114]	2.05" [52]	3.14" [80]	2.56" [65]	1.02" [26]	

CQB24-SR-R

Modulating, Non-Spring Return, 24 V, 2 VDC Close 10 VDC Open or 4...20 mA



Technical Data

Power Supply	24 VAC, $\pm 20\%$, 50/60 Hz, 24 VDC, $\pm 10\%$
Power consumption in operation	0.4 W
Power consumption in rest position	0.3 W
Transformer sizing	1 VA (class 2 power source)
Electrical Connection	18 GA plenum cable, 3 ft [1 m], with 1/2" conduit connector
Overload Protection	electronic throughout 0° to 90° rotation
Operating Range	DC 2...10 V, 4...20 mA w/ ZG-R01 (500 Ω , 1/4 W resistor)
Angle of rotation	90°, adjustable with mechanical stop
Position indication	pointer
Running Time (Motor)	75 sec
Ambient humidity	5...95% r.H. non condensing (EN 60730-1)
Ambient temperature	35...104°F [1.7...40°C]
Non-operating temperature	-40...176°F [-40...80°C]
Degree of Protection	IP40, NEMA 2
Housing material	UL94-5VA
Agency Listing	cULus acc. to UL60730-1A/-2-14, CAN/CSA E60730-1:02, CE acc. to 2004/108/EC and 2006/95/EC
Noise level, motor	max. 35 dB (A)
Maintenance	maintenance free
Quality Standard	ISO 9001
Weight	0.55 lb [0.20 kg]

† Use flexible metal conduit. Push the listed conduit fitting device over the actuator's cable to butt against the enclosure. Screw in conduit connector. Jacket the actuators input wiring with listed flexible conduit. Properly terminate the conduit in a suitable junction box. Rated impulse Voltage 800V. Type of action 1. Control pollution degree 3.

Application

Non-Spring Return proportional ZoneTight actuator.

Valve selection should be done in accordance with the flow parameters and system specifications. The actuator is mounted directly to the valve without the need for tools or additional linkage.

The actuator operates in response to a 2 to 10 VDC or 4 to 20mA control signal.

Safety Notes

⚠ WARNING: For Belimo Products sold in California, these Products do or may contain chemicals which are known to the State of California to cause cancer and or birth defects or other reproductive harms. For more information see www.p65warnings.ca.gov.

Wiring Diagrams
INSTALLATION NOTES

- Actuators may be connected in parallel. Power consumption and input impedance must be observed.
- Actuators may also be powered by 24 VDC.
- Only connect common to negative (-) leg of control circuits.
- A 500 Ω resistor (ZG-R01) converts the 4 to 20 mA control signal to 2 to 10 VDC.
- Actuators with plenum cable do not have numbers; use color codes instead.
- Meets cULus requirements without the need of an electrical ground connection.

WARNING! LIVE ELECTRICAL COMPONENTS!
 During installation, testing, servicing and troubleshooting of this product, it may be necessary to work with live electrical components. Have a qualified licensed electrician or other individual who has been properly trained in handling live electrical components perform these tasks. Failure to follow all electrical safety precautions when exposed to live electrical components could result in death or serious injury.

